

DESCRIPTION

The LX8580A is a high-performance, very low dropout voltage regulator, designed for use with advanced microprocessors, micro controllers, or video graphics controllers. This product can be used with separate voltage supplies for the control and power sections, allowing a power regulation dropout voltage as low as 100mV @ 1.5A. In AGP bus systems requiring regulation of 3.3V to 2.85V @ 3A, the LX8580A has a max dropout of 250mV making it an ideal power supply solution for today's graphics applications.

The LX8580A can also be used in a single voltage supply configuration with a dropout performance

similar to that of the LX8584 (1.3V @ 7.5A).

The LX8580A is supplied in a five-terminal TO-220, TO-263, or Linfinity's S-PAK packages, which allows the implementation of remote (Kelvin) voltage sensing. This sensing compensates for output voltage variations due to load changes and resistive voltage drops in connectors and board traces. Typical load regulation measured at the sense pin is less than 1mV for a load current step of 7mA to 7.5A.

The LX8580A is ideal for generating a secondary 2V-2.85V low voltage supply on a motherboard where a 3.3V supply is already available.

KEY FEATURES

- Low Dropout, 650mV at 7.5A Output Current in Dual Supply Mode
- Fast Transient Response
- Remote Sensing
- 1mV Load Regulation
- Adjustable Output

APPLICATIONS/BENEFITS

- Microprocessor/Micro controller Supplies
- 3.3V to 2.85V Voltage Conversion
- High-Current Regulators
- Post Regulation for Switching Power Supplies

IMPORTANT: For the most current data, consult MICROSEMI's website: <http://www.microsemi.com>

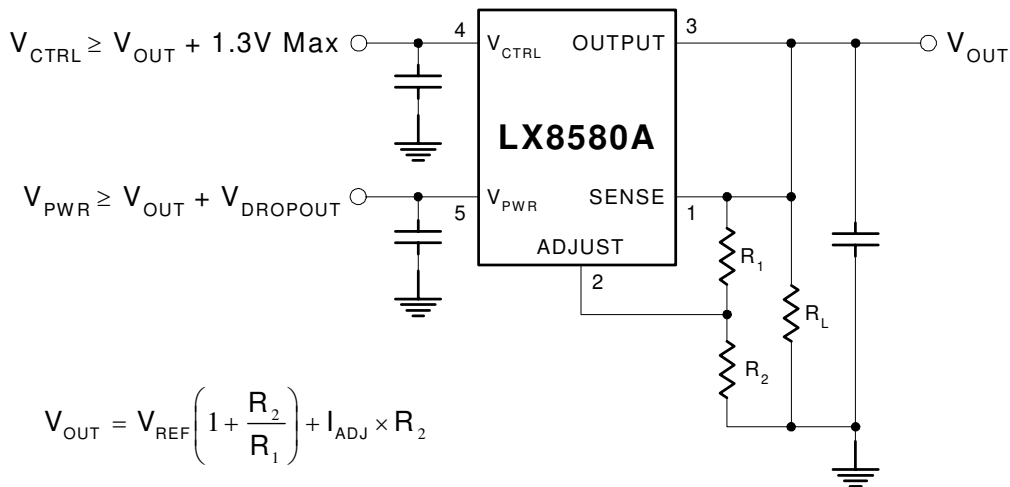
PRODUCT HIGHLIGHT

PACKAGE ORDER INFO

T _A (°C)	DROPOUT VOLTAGE	P	DF	DD
		Plastic TO-220 5-Pin RoHS Compliant Transition DC: 0543	S-PAK 5-pin RoHS Compliant Transition DC: 0515	Plastic TO-263 5-PIN RoHS Compliant Transition DC: 0535
0 to 125	0.1V – 0.7V	LX8580A-00CP	LX8580A-00CDF	LX8580A-00CDD

Note: Available in Tape & Reel. Append the letters "TR" to the part number. (i.e. LX8580A-00CDD-TR)

ABSOLUTE MAXIMUM RATINGS

V_{CTRL} Input Voltage.....	13V
V_{PWR} Input Voltage	7V
Power Dissipation	Internally Limited
Operating Junction Temperature.....	150°C
Storage Temperature Range.....	-65°C to 150°C
Peak Package Solder Reflow Temp. (40 second maximum exposure).....	260°C (+0, -5)

Note: Exceeding these ratings could cause damage to the device. All voltages are with respect to Ground. Currents are positive into, negative out of specified terminal.

THERMAL DATA
P Plastic TO-220 5-Pin

THERMAL RESISTANCE-JUNCTION TO TAB, θ_{JT}	3.0°C/W
THERMAL RESISTANCE-JUNCTION TO AMBIENT, θ_{JA}	65°C/W

DD Plastic TO-263 5-Pin

THERMAL RESISTANCE-JUNCTION TO TAB, θ_{JT}	3.0°C/W
THERMAL RESISTANCE-JUNCTION TO AMBIENT, θ_{JA}	35°C/W

DF Plastic S-Pack 5-Pin

THERMAL RESISTANCE-JUNCTION TO TAB, θ_{JT}	3.0°C/W
THERMAL RESISTANCE-JUNCTION TO AMBIENT, θ_{JA}	35°C/W

Junction Temperature Calculation: $T_J = T_A + (P_D \times \theta_{JA})$. θ_{JA} assume device is mounted on a 0.5 inch² copper pad. The θ_{JA} numbers are guidelines for the thermal performance of the device/pc-board system. All of the above assume no ambient airflow.

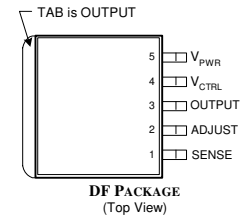
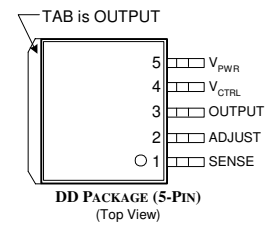
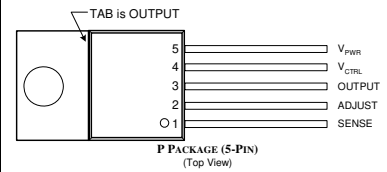
PACKAGE PIN OUT

RoHS 100% Matte Tin Lead Finish

FUNCTIONAL PIN DESCRIPTION

PIN	NAME	DESCRIPTION
1	SENSE	This pin is the positive side of the reference voltage for the device. With this pin it is possible to Kelvin-sense the output voltage at the load.
2	ADJUST	This pin is the negative side of the reference voltage for the device. Ripple rejection can be improved by adding a small bypass capacitor from the ADJUST pin to ground. The capacitor value should be selected so that: $C_R \leq \frac{1}{2\pi F_R R_1}$ where F_R is the ripple frequency and R_1 is the value of the resistor between the ADJUST and SENSE leads of the LX8580A
3	OUTPUT	This is the regulated power output of the device
4	V_{CTRL}	This pin is the voltage supply pin for the control circuitry of the device. The current flow into this pin will be about 1% of the output current. Please refer to the electrical characteristics section of the data sheet for dropout voltage for load conditions.
5	V_{PWR}	This is the collector of the power section of the LX8580A. The output load current is supplied through this pin. For the device to regulate, the voltage at this pin must be between 0.1V and 0.8V greater than the output voltage (Higher output current require higher voltage differences between V_{PWR} and OUTPUT).

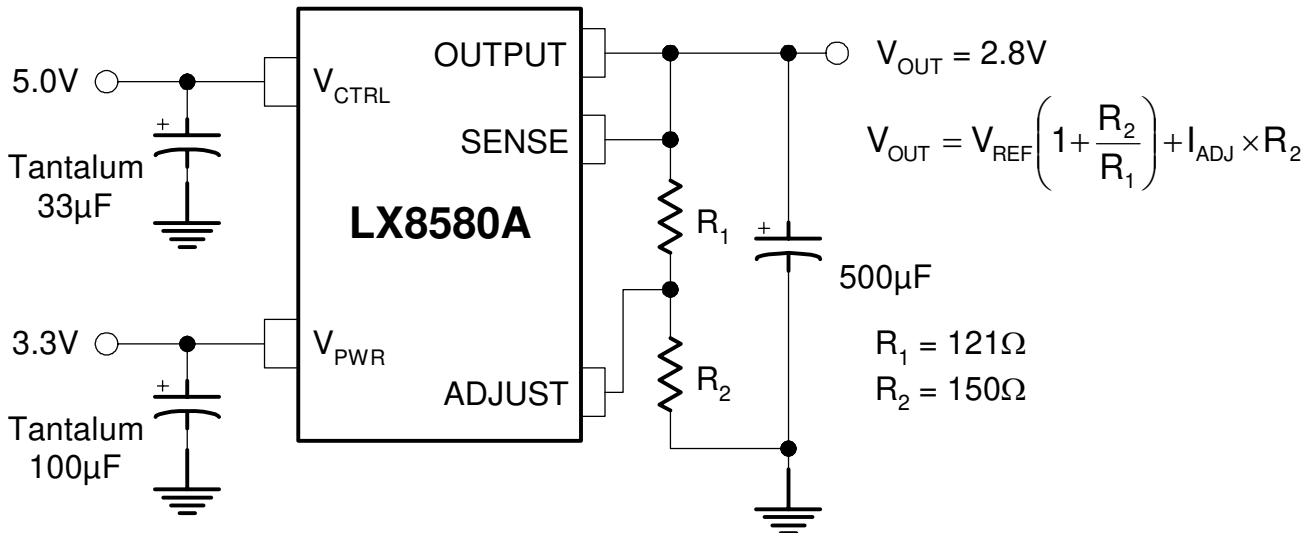
TYPICAL APPLICATION

Figure 1 – Typical Application

ELECTRICAL CHARACTERISTICS

Unless otherwise specified, the following specifications apply over the operating ambient temperature $0^{\circ}\text{C} \leq T_A \leq 125^{\circ}\text{C}$. Low duty cycle pulse testing techniques are used which maintains junction and case temperatures are equal to the ambient temperature.

Parameter	Symbol	Test Conditions	LX8580A			Units
			Min	Typ	Max	
Reference Voltage	V_{REF}	$V_{CTRL} = 2.75\text{V}$, $V_{PWR} = 2\text{V}$, $I_{LOAD} = 10\text{mA}$, $T_A = 25^{\circ}\text{C}$	1.243	1.250	1.257	V
		$V_{CTRL} = 2.7\text{V}$ to 6V , $V_{PWR} = 1.75\text{V}$ to 5.5V $I_{LOAD} = 10\text{mA}$ to 4A	1.237	1.250	1.263	
		$V_{CTRL} = 2.7\text{V}$ to 6V , $V_{PWR} = 2.05\text{V}$ to 5.5V $I_{LOAD} = 10\text{mA}$ to 7.5A	1.237	1.250	1.263	
Line Regulation	$\Delta V_{REF}(V_{IN})$	$V_{CTRL} = 2.5\text{V}$ to 10V , $V_{PWR} = 1.75\text{V}$ to 5.5V $I_{LOAD} = 10\text{mA}$, $T_A = 25^{\circ}\text{C}$		1	3	mV
		$V_{CTRL} = 2.5\text{V}$ to 10V , $V_{PWR} = 1.75\text{V}$ to 5.5V $I_{LOAD} = 10\text{mA}$		2	6	mV
Load Regulation	$\Delta V_{REF}(I_{OUT})$	$V_{CTRL} = 2.75\text{V}$, $V_{PWR} = 2.1\text{V}$ $I_{LOAD} = 10\text{mA}$ to 7.5A ($V_{ADJ} = 0$)		2	7	mV
Thermal Regulation	$\Delta V_{OUT}(Pwr)$	30ms Pulse		0.002	0.020	%/W
Thermal Resistance	$R_{\theta JT}$	Control Circuitry/Power Transistor		0.65	2.70	$^{\circ}\text{C}/\text{W}$
Ripple Rejection		$V_{CTRL} = V_{PWR} = 3.75\text{V Avg}$, $V_{RIPPLE} = 1\text{V}_{P-P}$ $V_{ADJ} = 0$, $I_{OUT} = 4\text{A}$	60	80		dB
V_{CTRL} Pin Current (Note 2)	I_{CTRL}	$V_{CTRL} = 2.75\text{V}$, $V_{PWR} = 2.05\text{V}$, $I_{LOAD} = 100\text{mA}$		3	10	mA
		$V_{CTRL} = 2.75\text{V}$, $V_{PWR} = 2.05\text{V}$, $I_{LOAD} = 3\text{A}$		30	50	
		$V_{CTRL} = 2.75\text{V}$, $V_{PWR} = 1.75\text{V}$, $I_{LOAD} = 3\text{A}$		33	55	
		$V_{CTRL} = 2.75\text{V}$, $V_{PWR} = 2.05\text{V}$, $I_{LOAD} = 7.5\text{A}$		70	120	
Adjust Pin Current	I_{ADJ}	$V_{CTRL} = 2.75\text{V}$, $V_{PWR} = 2.05\text{V}$, $I_{LOAD} = 0\text{mA}$, $V_{ADJ} = 0$	20	60	100	μA
Current Limit	$I_{OUT(MAX)}$	$V_{CTRL} = 2.75\text{V}$, $V_{PWR} = 2.05\text{V}$, $\Delta V_{OUT} = 100\text{mV}$, $V_{ADJ} = 0$	7.7	9		A
Dropout Voltage (Control Section) Minimum V_{CTRL} (Note 1) ($V_{PWR} - V_{OUT}$)	$V_{CTRL} - V_{OUT}$	$V_{PWR} = 2.05$, $I_{LOAD} = 100\text{mA}$		0.90	1.15	V
		$V_{PWR} = 2.05$, $I_{LOAD} = 1.5\text{A}$		1.00	1.15	
		$V_{PWR} = 2.05$, $I_{LOAD} = 3\text{A}$		1.05	1.18	
		$V_{PWR} = 2.05$, $I_{LOAD} = 5\text{A}$		1.06	1.20	
		$V_{PWR} = 2.05$, $I_{LOAD} = 7.5\text{A}$		1.10	1.30	
Dropout Voltage (Power Section) Minimum V_{PWR} (Note 1) ($V_{PWR} - V_{OUT}$) ($V_{ADJ} = 0$)	$V_{PWR} - V_{OUT}$	$V_{CTRL} = 2.75\text{V}$, $I_{LOAD} = 100\text{mA}$		0.03	0.05	V
		$V_{CTRL} = 2.75\text{V}$, $I_{LOAD} = 1.5\text{A}$, $T_A = 85^{\circ}\text{C}$		0.10	0.13	
		$V_{CTRL} = 2.75\text{V}$, $I_{LOAD} = 1.5\text{A}$		0.13	0.15	
		$V_{CTRL} = 2.75\text{V}$, $I_{LOAD} = 3\text{A}$, $T_A = 85^{\circ}\text{C}$		0.20	0.25	
		$V_{CTRL} = 2.75\text{V}$, $I_{LOAD} = 3\text{A}$		0.25	0.28	
		$V_{CTRL} = 2.75\text{V}$, $I_{LOAD} = 5\text{A}$, $T_A = 85^{\circ}\text{C}$		0.38	0.43	
		$V_{CTRL} = 2.75\text{V}$, $I_{LOAD} = 5\text{A}$		0.40	0.45	
		$V_{CTRL} = 2.75\text{V}$, $I_{LOAD} = 7.5\text{A}$, $T_A = 85^{\circ}\text{C}$		0.52	0.65	
$V_{CTRL} = 2.75\text{V}$, $I_{LOAD} = 7.5\text{A}$		0.59	0.70			
Minimum Load Current		$V_{CTRL} = 5\text{V}$, $V_{PWR} = 3.3\text{V}$, $V_{ADJ} = 0$ Note 3		5	10	mA

Note 1: Dropout is caused by either minimum control voltage (V_{CTRL}) or minimum power voltage (V_{PWR}). Both parameters are specified with respect to the output voltage. The specifications represent the minimum input/output voltage required to maintain 1% regulation.

Note 2: The control pin current is the drive current required for the output transistor. This current will track output current with roughly a 1:100 ratio. The minimum value is equal to the quiescent current of the device.

Note 3: Minimum load current is defined as the amount of output current required to maintain regulation. Typically this current provides the bias to the external resistor divider network used to set the output voltage.

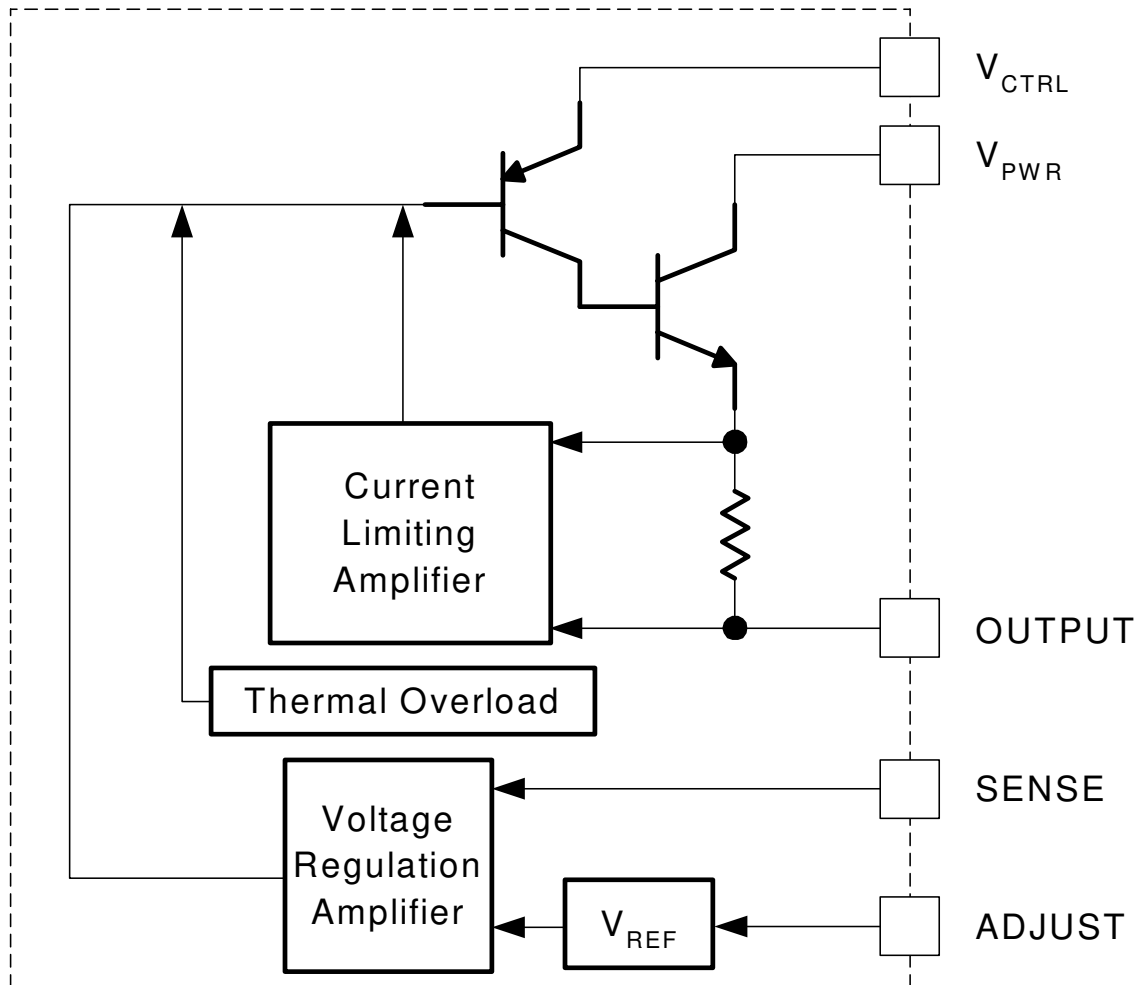
SIMPLIFIED BLOCK DIAGRAM

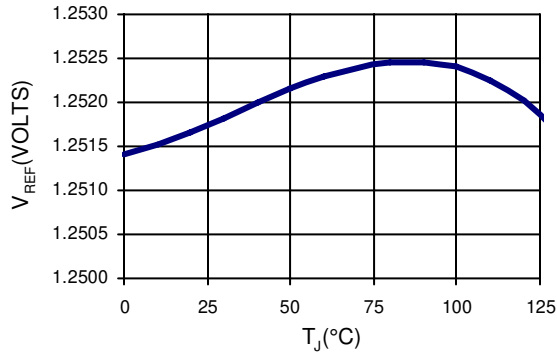
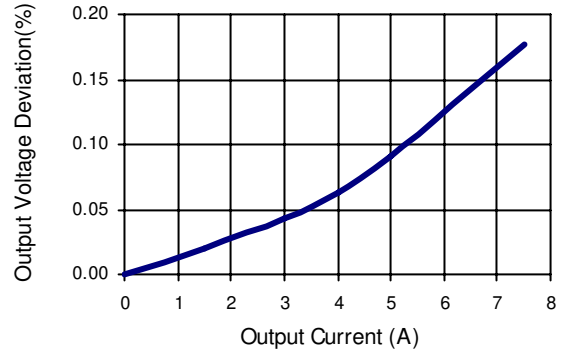
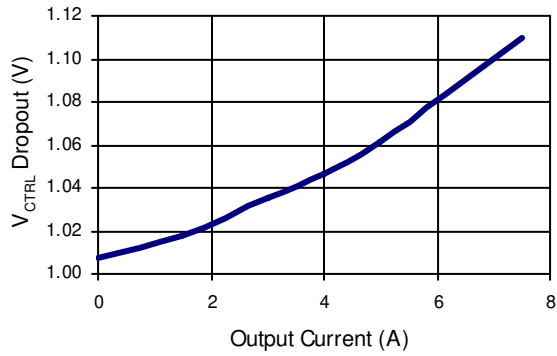
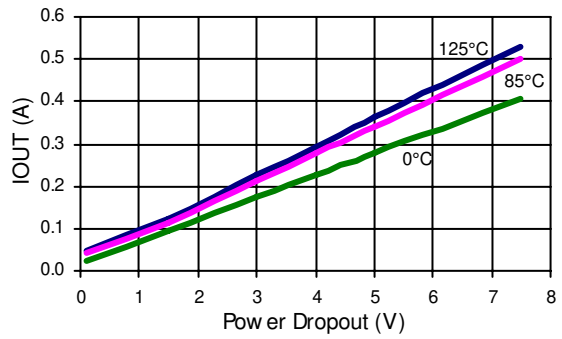
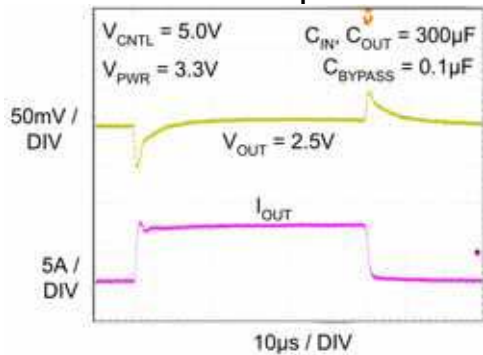
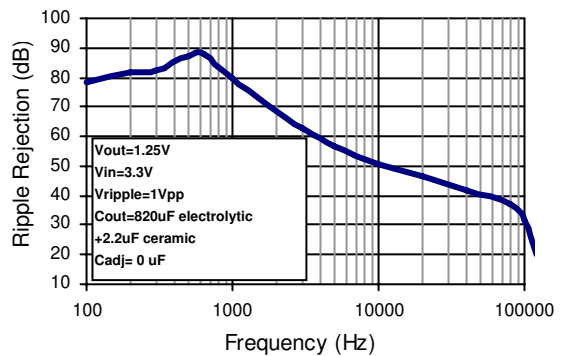
Figure 2 – Simplified Block Diagram

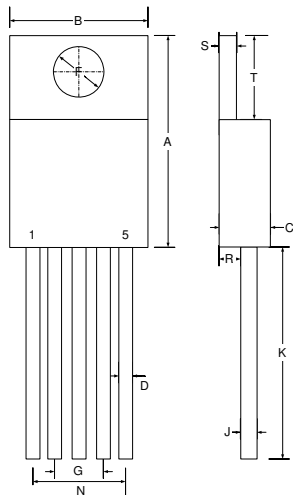
CHARACTERISTIC CURVES
Reference Voltage vs. Temperature

Load Regulation vs. Output Current

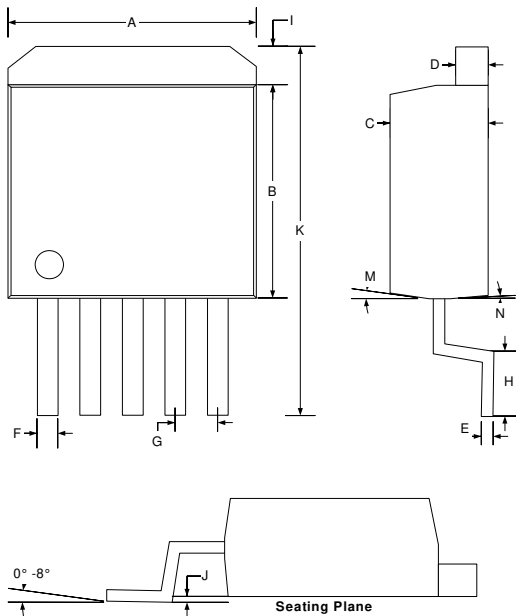
 V_{CTRL} Dropout, $V_{PWR}=3.25V$

 V_{PWR} Dropout Voltage vs. I_{OUT}

Transient Response

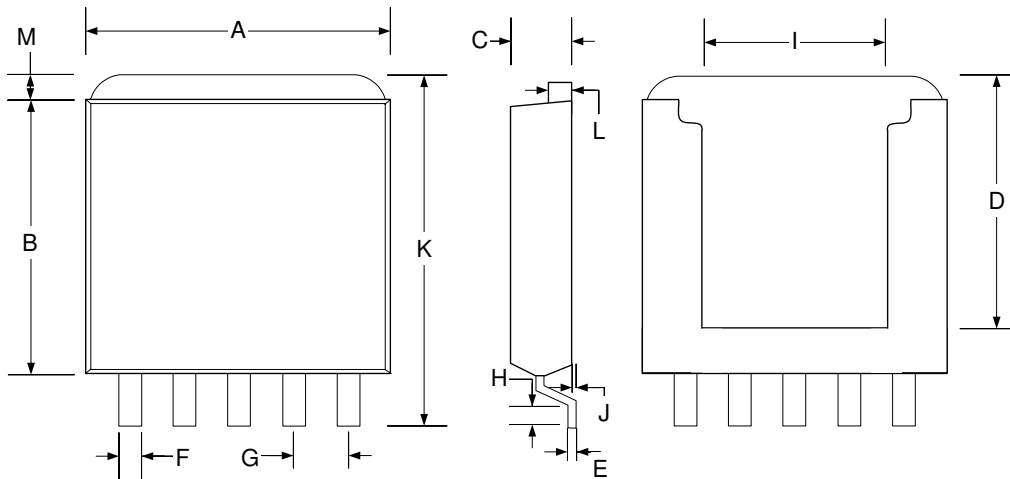
Ripple Rejection

PACKAGE DIMENSIONS
P 5-Pin Plastic TO-220

Dim	MILLIMETERS		INCHES	
	MIN	MAX	MIN	MAX
A	14.23	16.51	0.560	0.650
B	9.66	10.66	0.380	0.420
C	3.56	4.82	0.140	0.190
D	0.46	0.89	0.018	0.035
F	3.56	4.06	0.140	0.160
G	3.40		0.134	
J	0.31	1.14	0.012	0.045
K	12.70	14.73	0.500	0.580
N	6.80 TYP		0.268 TYP	
R	2.04	2.92	0.080	0.115
S	1.14	1.39	0.045	0.055
T	5.85	6.85	0.230	0.270

DD 5-Pin Plastic TO-263

Dim	MILLIMETERS		INCHES	
	MIN	MAX	MIN	MAX
A	10.03	10.67	0.395	0.420
B	8.51	9.17	0.335	0.361
C	4.19	4.59	0.165	0.181
D	1.14	1.40	0.045	0.055
E	0.330	0.51	0.013	0.020
F	0.74	0.89	0.029	0.035
G	1.57	1.83	0.062	0.072
H	2.29	2.79	0.090	0.110
I	—	1.65	—	0.065
J	0	0.25	0	0.010
K	14.60	15.87	0.575	0.625
M	7°		7°	
N	3°		3°	

PACKAGE DIMENSIONS
DF 5-Pin Plastic S-Pak

Dim	MILLIMETERS		INCHES	
	MIN	MAX	MIN	MAX
A	9.27	9.52	0.365	0.375
B	7.87	8.13	0.310	0.320
C	1.78	2.03	0.070	0.080
D	8.03 BSC		0.316 BSC	
E	0.25 BSC		0.010 BSC	
F	0.63	0.79	0.025	0.031
G	1.70 BSC		0.067 BSC	
H	0.79	1.04	0.031	0.041
I	6.50 BSC		0.256 BSC	
J	0.03	0.13	0.001	0.005
K	10.41	10.67	0.410	0.420
L	0.25 BSC		0.01 BSC	
M	0.76	1.27	0.03	0.05

Note: Dimensions do not include mold flash or protrusions; these shall not exceed 0.155mm(.006") on any side. Lead dimension shall not include solder coverage.



LX8580A

7.5A Very Low Dropout Positive Regulator

PRODUCTION DATA SHEET

NOTES

PRODUCTION DATA – Information contained in this document is proprietary to Microsemi and is current as of publication date. This document may not be modified in any way without the express written consent of Microsemi. Product processing does not necessarily include testing of all parameters. Microsemi reserves the right to change the configuration and performance of the product and to discontinue product at any time.