



Range and Resolution

760 to 0 torr absolute

1 torr resolution

Consult factory or see cecomp.com for models with higher resolution and additional features

Accuracy

Accuracy includes linearity, hysteresis, repeatability

Std. accuracy: ±0.25% FS ±1 LSD, (approx. ±3 torr)

HA high accuracy: ±0.1% FS ±1 LSD, (approx. ±2 torr)

Sensor hysteresis: ±0.015% FS, included in accuracy

Sensor repeatability: ±0.01% FS, included in accuracy

Display

3 readings per second nominal display update rate

3 digit LCD, 0.5" H digits

BL: Red LED display backlight on when gauge is on

Calibration

Front calibration potentiometers

Non-interactive zero and span

±10% range

Housing

Extruded aluminum case, epoxy powder coated, ABS/ polycarbonate bezel, front and rear gaskets, polycarbonate label, NEMA 2

Weight

Approximately 9 ounces, shipping weight 1 pound.

Connection and Material

1/4" NPT male fitting, 316L stainless steel

All wetted parts are 316L stainless steel

Overpressure, Burst

2 X pressure range (approx. 30 psig)

4 X sensor burst pressure rating (approx. 60 psig)

Environmental Temperatures

Storage temperature: -40 to 203°F (-40 to 95°C)

Operating temperature: -4 to 180°F (-20 to 82°C)

Sensor compensated range: 32 to 158°F (0 to 70°C)

ARM760B Battery Powered

Batteries and Battery Life

Two AA alkaline included

ARM760B: 2500 hours (approximately)

ARM760BBL: 180 hours (approximately)

Low battery indication on display

Controls

Front button turns gauge on/off, starts auto shutoff timer

Auto Shutoff

Factory set to 5 minutes

Optional 10 minutes, 30 minutes or no auto shutoff

ARM760AD Low Voltage Powered

Controls

Front button turns gauge on/off

Electrical Connection

Gauge: 6 foot long, 2-conductor cable with female 3.5 mm socket

Power supply: 6 foot long, 2-conductor cable with male 3.5 mm plug

Power

9-32 VDC or 8-24 VAC 50/60 Hz

Includes 115VAC/12VDC wall mount power supply

Power Consumption

ARM760AD: 5 mA (approximately)

ARM760ADBL: 75 mA (approximately)

- Monitor Vacuum Systems and Pumps
- Replace Mercury Manometers
- Vacuum Packaging Machinery
- ±0.25% Test Gauge Accuracy
- 316 Stainless Steel Wetted Parts
- 760 to 0 Torr Absolute
- Battery or Externally Powered Versions



ARM760B with RB Rubber Boot



ARM760B

ARM760AD

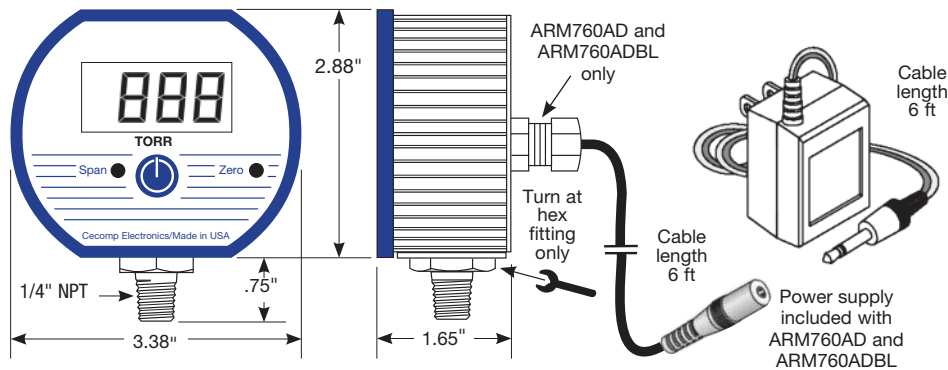

How to Specify	Type
ARM760B - time - options	Battery powered
ARM760BBL - time - options	Battery powered, backlit display
ARM760AD - options	Low voltage powered
ARM760ADBL - options	Low voltage powered, backlit display

Time—Battery powered model auto shutoff time (factory configured)

5	5 minutes. Default if not specified.
10	10 minutes
30	30 minutes
ON	No auto shutoff. On/off via front button.

Options—add to end of model number. Factory installed only. See cecomp.com/accessories for details.

HA	High accuracy, ±0.1% FS ±1 LSD
PM	Panel mount, 4.1" x 4.1"
MC	Metal front cover instead of plastic
CS	Case bottom stiffener plate
CC	Moisture resistant circuit board conformal coating
TP	Top port, gauge port on top of case
SM	Surface mount plate. Battery powered only.

Calibration Cert. Option—add to end of model number

NC	NIST traceability documentation, 5 points and date
----	--

TP
Top gauge port. Primarily used with tire pressure applications. Not available with NEMA 4X models.

Accessories—order separately

RB
High visibility orange rubber boot protects gauge for portable applications. Not available with NEMA 4X models.

SCR14SS
Filter screen fitting keeps debris out of gauge sensor. For food vacuum packaging applications. 303SS body, 100 micron 304SS screen.

CON14SS
Quick connector to install or remove gauge without tools. 304 stainless steel, urethane seal.





Precautions

- ✓ Read and understand all instruction sheet information. Contact us for help, instructions, or repairs.
- ✓ Batteries should be replaced when the low battery indicator comes to prevent unreliable readings. If gauge is used infrequently, remove batteries to prevent damage from leaky batteries. Inspect batteries at least annually.
- ✓ **Use specified power only.** Improper voltages will damage the gauge. NEVER connect the gauge power wires directly to an electrical outlet or permanent damage will result.
- ✓ Gauges are not intended for permanent outdoor use. Protect from weather and excessive humidity. NEMA 4X models are suitable for temporary outdoor use and wash down areas.
- ✓ Install gauge so it is protected from impact damage.
- ✓ Media temperature and gauge ambient temperature must be within specified ranges.
- ✓ Use a screen or filter to avoid clogging gauge port when measuring contaminated media.
- ✓ Use thread sealant to ensure leak-free operation.
- ✓ Media being measured must be compatible with 316L SS.
- ✓ Avoid sensor damage! Sensor diaphragm is thin 316L SS foil. Never insert objects into the gauge port or blow out with compressed air.
- ✓ Avoid sensor damage! Hydraulic or liquid pumping systems must include a shock suppressor to protect gauge sensor from damaging pressure spikes or water hammer.
- ✓ Avoid sensor damage! Do not apply vacuum to non-vacuum gauges or hydraulic vacuum to any gauge.
- ⚠ Do not exceed pressure range indicated on gauge label.
- ⚠ Remove system pressure before removing or installing gauge.
- ⚠ Use fittings appropriate for the pressure range of the gauge.
- ⚠ Gauges are not for oxygen service. Accidental rupture of sensor diaphragm may cause silicone oil inside sensor to react with oxygen.
- ⚠ Only gauges marked as Intrinsically Safe can be used in hazardous locations or in the presence of flammable or explosive substances, or atmospheres.

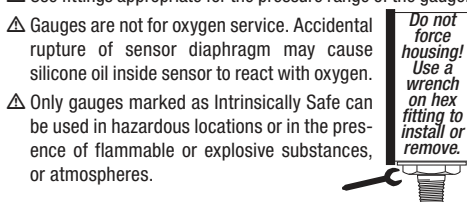

Cecomp maintains a constant effort to upgrade and improve its products. Specifications are subject to change without notice. See cecomp.com for latest product information. Consult factory for your specific requirements.



WARNING: This product can expose you to chemicals including nickel which is known to the State of California to cause cancer or birth defects or other reproductive harm. For more information go to www.P65Warnings.ca.gov

Installation Tip

For food vacuum packaging applications an accumulation of debris may eventually clog the gauge port. A filter screen fitting should be installed to keep debris out of the gauge port. The screen fitting can be removed and cleaned as needed.



Description

Absolute reference gauges read zero at full vacuum and atmospheric pressure with the gauge port open.

With the gauge port open, it is normal for the reading to constantly change in response to atmospheric pressure changes. The ARM760B and ARM760BBL models are designed for portable applications such as checking vacuum systems and packaging machinery.

The ARM760AD and ARM760ADBL models are designed for applications where a continuous display of vacuum is required such as monitoring vacuum systems and pumps.

Installation: ARM760AD, ARM760ADBL

The ARM760AD and ARM760ADBL models include 6 feet of cable with a female connector and a 115VAC/12VDC adapter with 6 feet of cable with plug.

After the gauge is installed, route the wires away from heat sources and moving equipment and connect the AC adapter's plug to the gauge cable connector. Lastly, plug the AC adapter into a 115 VAC outlet.

NEVER connect the gauge wires directly to 115 VAC or permanent damage not covered by warranty will result.

If you are using your own power source the ARM760AD and ARM760ADBL models can operate on any AC source of 8 to 24 VAC 50/60 Hz, or any DC source of 9 to 32 VDC. The type and magnitude of the supply voltage have negligible effects on the gauge calibration as long as it is within the voltage ranges stated above. No polarity needs to be observed when connecting a DC supply.

The only important consideration is to ensure that the gauge supply voltage does not fall below 8 VAC RMS if AC power is used, or 9 VDC if DC power is used. Operation with less than these values may cause erratic or erroneous readings.

If your application requires operation of several gauges from the same power supply, observe power requirements in specifications.

Operation: ARM760AD, ARM760ADBL

If the gauge display is off, press the center button to power up the gauge.

If the gauge was in the power-on state when the power was disconnected, the gauge will automatically turn on when power is reapplied.

If the gauge was turned off using the push button and then the power was turned off, the gauge will not power up until the power is reapplied and the center button is pressed again. The gauge may be left on at all times or shut off when not in use.

Display backlighting for BL models is on whenever the gauge is on. The backlighting will not be apparent under bright lighting conditions.

Operation: ARM760B, ARM760BBL

Press the button on the front of the gauge to activate the display.

The gauge can be shut off at any time by pressing the button again.

The gauge will stay on for a period of time determined by the auto shutoff time.

If the gauge was ordered without auto shutoff (-ON) it will stay on until the button is pressed or until the batteries are depleted. Display backlighting for BL models is on whenever the gauge is on. The backlighting will not be apparent under bright lighting conditions.

Turn gauge off when not in use to conserve batteries.

Battery Replacement: ARM760B, ARM760BBL

A LOBAT low battery indication will be shown in the upper left corner of the display when the battery voltage falls sufficiently. The batteries should be replaced when the indicator comes to prevent unreliable readings.

WARNING: Batteries must be changed in a non-hazardous location only. Do not mix different batteries or fresh batteries with old. Replace both batteries with new ones at the same time.

1. Remove the 6 Phillips screws on the back of the gauge.
2. Remove battery holder.
3. Remove batteries by lifting up the positive end of the battery (opposite the spring) taking care not to bend the spring.
4. Discard old batteries properly. See battery manufacturer's recommendations for disposal or recycling.
5. Install batteries with correct orientation. Insert the negative (flat) end of each battery first towards the battery holder spring.
6. Replace the holder and back cover, including the rubber gasket.

Calibration Preparation

Gauges are factory calibrated at approximately 23°C using NIST traceable calibration equipment. Calibration is not required before using the gauge. Calibration intervals depend on your quality standards, but annual re-calibration is customary. Calibration should only be performed by qualified individuals using appropriate calibration standards and procedures.

Absolute reference gauges require vacuum generation and atmospheric pressure measurement equipment for accurate calibration and thus are more difficult to calibrate in the field.

Calibration should only be attempted if the user has access to an absolute pressure reference of known accuracy that can generate and measure pressure/vacuum over the full range of the gauge.

A vacuum pump able to produce a vacuum of 100 microns (0.1 torr or 100 millitorr) or lower is required for zero calibration.

The quality of the calibration is only as good as the accuracy of the calibration equipment and ideally should be at least four times the gauge accuracy.

Do not use a weather barometer for an atmospheric reference as they are normally offset to sea level based on altitude and thus do not read absolute atmospheric pressure.

Install fresh batteries before calibrating battery-powered gauges.

Allow the gauge to equalize to normal room temperature for approximately 20 minutes before calibration.

Gauges may be returned to factory for certified recalibration. NIST traceability is available.

Calibration

This procedure applies to all ARM760 models.

Remove the front covers to access the zero and span calibration potentiometers.

Apply a full vacuum to the gauge port.

Zero calibration must be done before span calibration.

Adjust the zero potentiometer until the gauge reads zero with the minus (-) sign occasionally flashing.

Adjusting zero does not affect the span calibration.

Set the pressure to obtain a calibrator reading of approximately 760 torr. Atmospheric pressure can be used, but constantly changes.

Adjust the span potentiometer to match the calibrator's reading.

Record readings at three to five points over the range of gauge and adjust span control to minimize error and meet specifications.