

Test Procedure for the NCP154MXTAGEVB Evaluation Board

There is a collection test procedures for NCP154 demoboards. This paper offers some helpful test configuration for first contact with ONSEMI NCP154 LDO.

1. QUIESCENT CURRENT

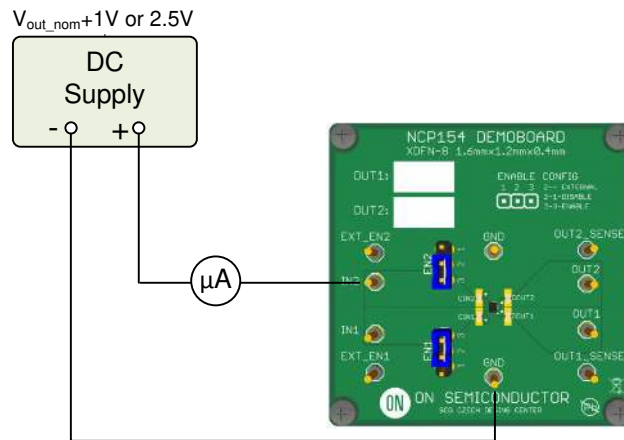

Figure 1: Test configuration for measurement I_Q , Quiescent Current

1. Connect circuit as shown figure on 1
2. Apply voltage at V_{Input} . Default test V_{input} is $V_{out_nom}+1$ V or 2.5 V whichever is greater
3. Value shown μA meter is measured quiescent current.
4. Measurement is finished. Disconnect supply voltage.

**Note – Be carefully if any device is connected on output, because leakage current can affect measurement accuracy.*



2. LOAD REGULATION

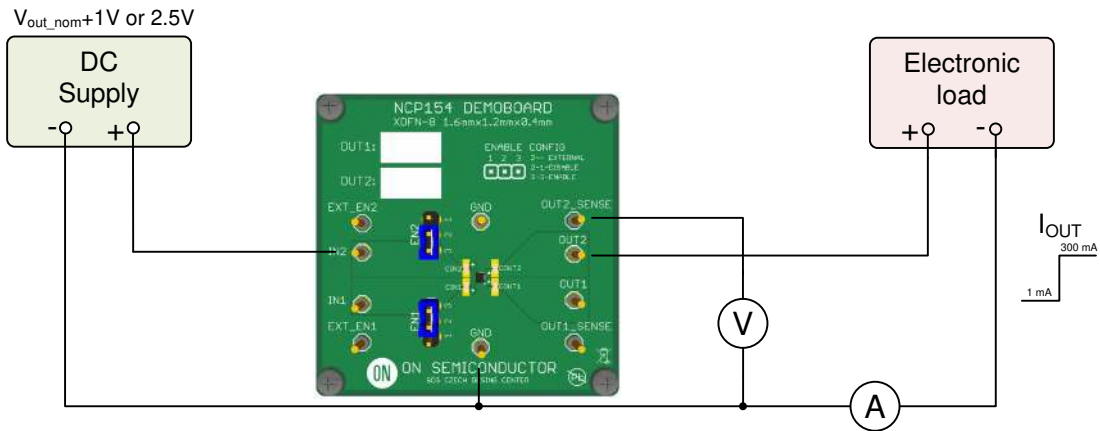

Figure 2: Test configuration for measurement REG_{LOAD} , Load Regulation

1. Connect circuit as shown figure on 2
2. Apply voltage at V_{input} . Default test V_{input} is $V_{out_nom}+1$ V or 2.5 V whichever is greater
3. Set minimal required current I_1 , e.g. 1 mA, and switch load ON.
4. Note the value V_1 from voltmeter V_o .
5. Switch load OFF and set maximal required current I_2 , e.g. 300 mA and switch load ON.
6. Note the value V_2 from voltmeter V_o .
7. Load regulation is obtained via following formula: $REG_{LOAD}=(V_1-V_2)$, [V]
8. Measurement is finished. Disconnect supply voltage.



3. LINE REGULATION

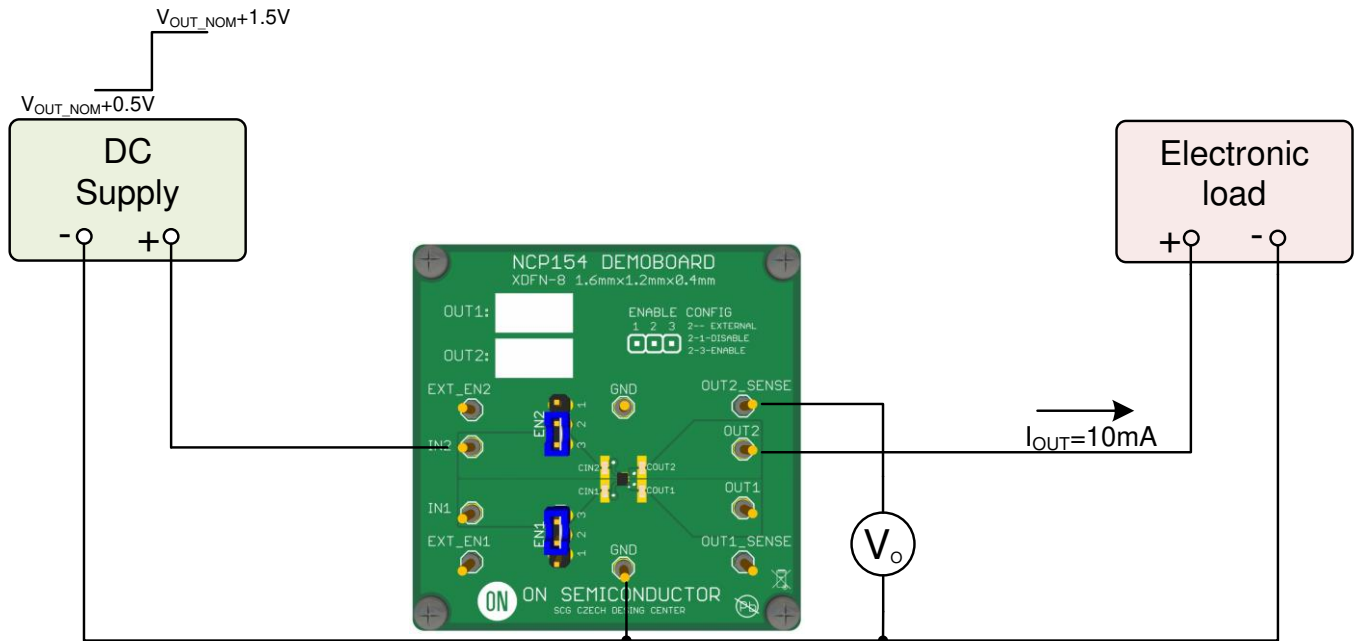

Figure 3: Test configuration for measurement REG_{LINE}, Line Regulation

1. Connect circuit as shown on figure 3
2. Set load to the required current e.g. 10 mA
3. Set minimal input voltage V_{I1} , $V_{OUT_NOM}+1V$ or 2.5V whichever is greater
4. Note the value V_{I1} and V_{O1} .
5. Set maximal input voltage $V_{I2} = 5.5 V$
6. Note the value V_{I2} and V_{O2} .
7. Load regulation is obtained via following formula: $REG_{LINE}=(V_{O1}-V_{O2})/(V_{I1}-V_{I2})$, [V/V]
8. Measurement is finished. Disconnect supply voltage.



4. ENABLE START-UP

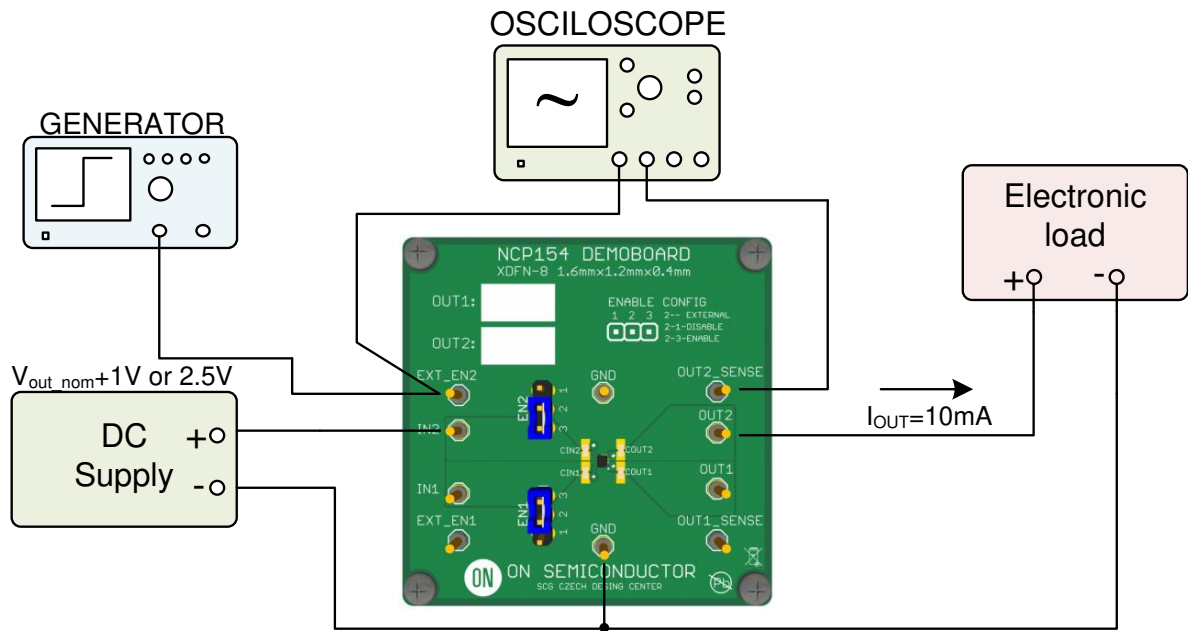

Figure 4: Test configuration for measurement enables response

1. Connect circuit as shown on figure 4
2. Set generator to SQUARE PULSE, $0.9 \leq \text{AMPLITUDE} \leq V_{\text{IN}}$, FREQUENCY=10Hz, DUTY=10%
3. Apply voltage at V_{Input} . Default test V_{Input} is $V_{\text{out_nom}}+1\text{ V}$ or 2.5 V whichever is greater
4. Set required I_{OUT} , e.g. 10 mA
5. Connect oscilloscope to EN signal and V_{OUTPUT} .
6. Watch enable response of the regulator after asserting EN pin.

Measurement is finished. Disconnect supply voltage.