

Order Number
203702-3800

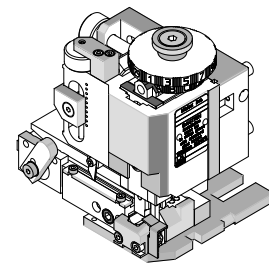

Application Tooling Specification



FEATURES

- Quick punch removal with the push of a button for fast and easy tooling change
- Applicator designed to industry-standard mounting and 135.80mm (5.346”) shut height
- Quick setup time; plus, the crimp height, track and feed adjustments can be set without removing the applicator from the press
- Fine adjustment allows users to achieve target with little effort by adjusting in increments of 0.015mm (.0006”) for conductor crimp height and 0.063mm (.0025”) for insulation height
- Independent adjustment rings allow users to quickly adjust the conductor or insulation crimp height without affecting each other
- This tool is IPC/WHMA-A-620 Class 2 Compliant, as indicated below
- Directly adapts to most automatic wire processing machines

SCOPE

Products: Micro-Fit Plus, 26-30 AWG (UL1061) Wires.

Terminal Series No.	Terminal Order No.	Wire Size		Insulation Diameter		Strip Length	
				IPC/WHMA-A-620 (1)			
		AWG	Wire Type	mm	In.	mm	In.
206460	206460-0011 206460-0012* 206460-0013*	26-30	UL1061	0.60-1.20	.024-.047	2.50-2.90	.098-.114
215953	215953-0011 215953-0012* 215953-0013*	26-30	UL1061	0.60-1.20	.024-.047	2.50-2.90	.098-.114

(1) To achieve optimum IPC/WHMA-A-620 insulation crimps, use this insulation OD range. For larger insulation diameters like UL1007, see FineAdjust Applicator 203702-3900.

*Terminal oiler 63801-7240 recommended when crimping gold-plated terminals.

DEFINITION OF TERMS

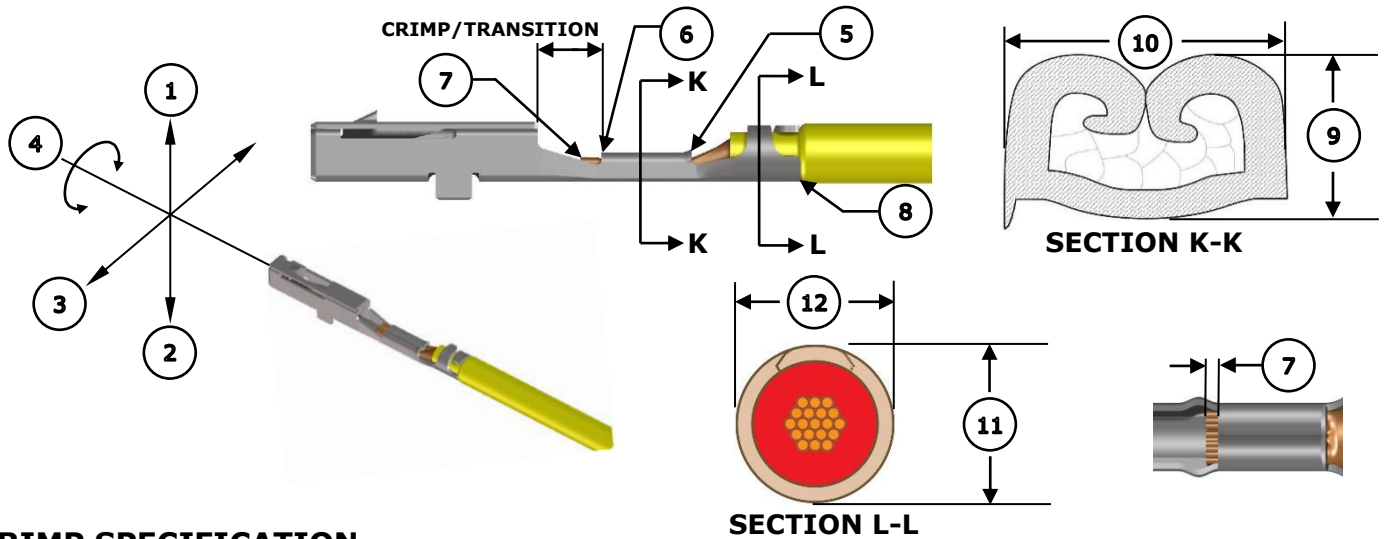

CRIMP SPECIFICATION

Feature	Requirement					
1. Bend Up	8° Max					
2. Bend Down	8° Max					
3. Twist	6° Max					
4. Roll	10° Max					
5. Bell Mouth Rear	0.05-0.40mm (.002-.016")					
6. Bell Mouth Front	Not Applicable					
7. Conductor Brush	0.00-0.80mm (.000-.031")					
8. Cut-Off Tab	0.30mm (.012") Max					
Conductor Crimp	Terminal Order No.	Wire Size	9. Crimp Height		10. Crimp Width (Ref)	
	206460	26 AWG	0.74-0.79mm	.029-.031 In.	1.10mm	.043 In.
	215953	28 AWG	0.71-0.76mm	.028-.030 In.	1.10mm	.043 In.
		30 AWG	0.69-0.74mm	.027-.029 In.	1.10mm	.043 In.
Insulation Crimp	Terminal Order No.	Wire Size	11. Crimp Height (Ref)		12. Crimp Width (Ref)	
	206460	26 AWG	1.50mm	.059 In.	1.40mm	.055 In.
	215953	28 AWG	1.40mm	.055 In.	1.40mm	.055 In.
		30 AWG	1.30mm	.051 In.	1.40mm	.055 In.
Pull Force	Terminal Order No.	Wire Size	Minimum Pull Force		To be measured with no influence from the insulation crimp.	
	206460	26 AWG	17.8 N	4.0 lb.		
	215953	28 AWG	11.1 N	2.5 lb.		
		30 AWG	7.1 N	1.6 lb.		

Tool Qualification Notes

1. Pull force should be measured with no influence from the insulation crimp.
2. The above specifications are guidelines to an optimum crimp.
3. Terminal Oiler (63801-7240) will improve tooling life and minimize crimp extrusions. See 63800-4900 FineAdjust manual.

PARTS LIST

FineAdjust Applicator 203702-3800				
Item	Order No.	Engineering No.	Description	Quantity
Perishable Tooling				
	203702-3870	203702-3870	Tool Kit (All "Y" Items)	REF
1	63444-1116	63444-1116	Conductor Punch	1 Y
2	63445-1128	63445-1128	Conductor Anvil	1 Y
3	63454-1402	63454-1402	Insulation Punch	1 Y
4	63445-1414	63445-1414	Insulation Anvil	1 Y
5	63443-0005	63443-0005	Cut-Off Plunger	1 Y
6	63443-0012	63443-0012	Front Plunger Retainer	1 Y
Other Components				
7	11-17-0022	1739-21	Compression Spring	1
8	11-18-4083	60707-8	Feed Guide	1
9	11-24-1067	4996-4	Cut-Off Plunger Spring	1
10	63443-0009	63443-0009	Front Scrap Chute	1
11	63443-0024	63443-0024	Key	1
12	63443-0090	63443-0090	Wire Stop	1
13	63443-0093	63443-0093	Shank	1
14	200213-7552	200213-7552	Anvil Mount	1
15	63443-2806	63443-2806	Front Plunger Striker	1
16	63443-2905	63443-2905	Wire Hold Down Plunger	1
17	63443-7137	63443-7137	Terminal Hold Down	1
18	63443-6113	63443-6113	Rear Cover	1
19	63600-0021	63600-0021	Compression Spring	1
Frame				
20	63800-4901	63800-4901	Top	1
21	63801-3281	63801-3281	Base	1
22	63801-4650	63801-4650	Track	1
Hardware				
23	—	—	M3 by 6 Long SHCS	2*
24	—	—	M3 by 6 Long FHCS	1*
25	—	—	M3 by 8 Long SHCS	1*
26	—	—	M4 by 6 Long SHCS	2*
27	—	—	M4 by 12 Long BHCS	2*
28	—	—	M4 by 50 Long SHCS	2*
29	—	—	M5 by 12 Long SHCS	1*
30	—	—	#10-32 by 3/8" Long Flat Point SSS	1*
31	—	—	#10-32 Hex Jam Nut	1*
* Available from an industrial supply company.				

ASSEMBLY DRAWING

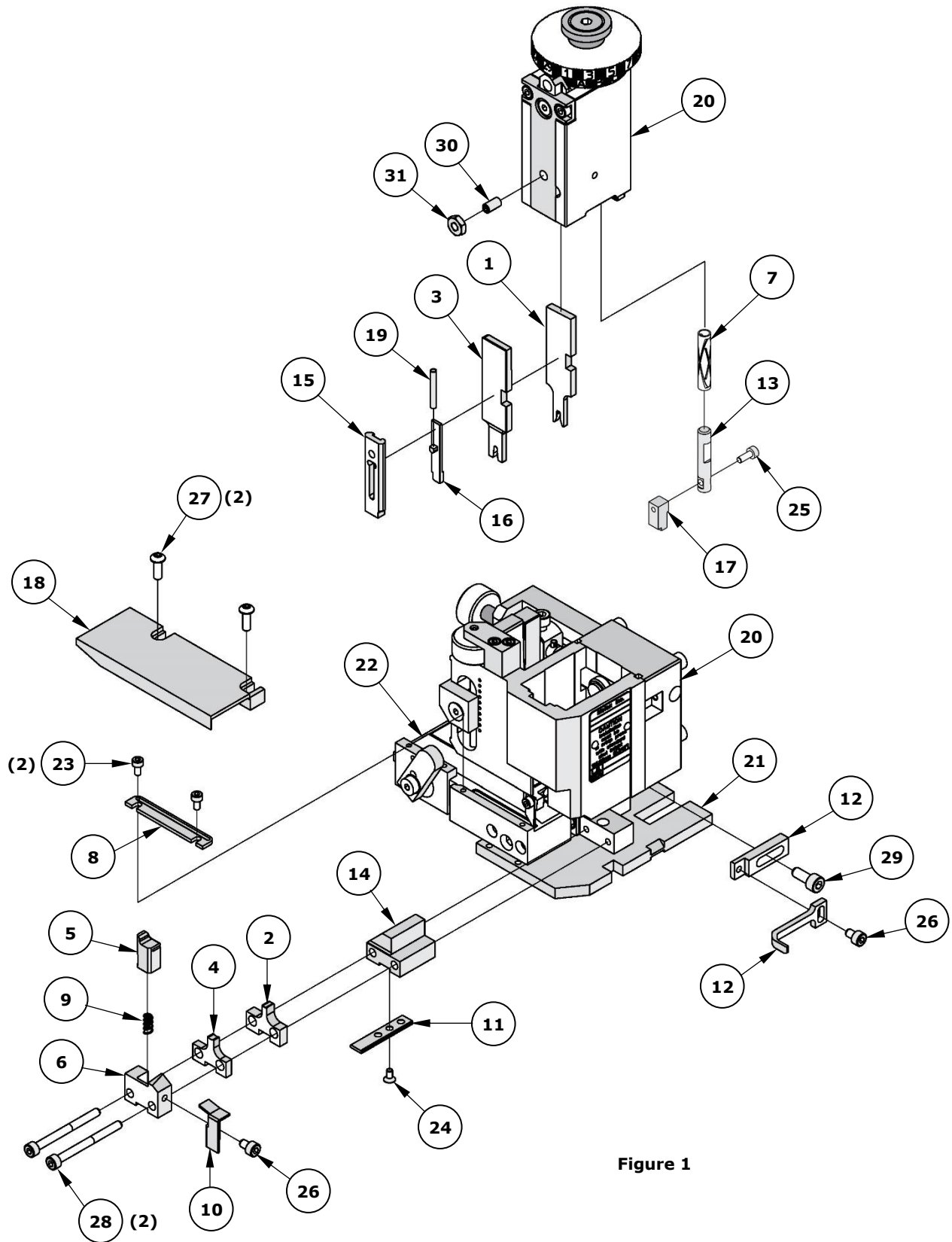

Figure 1

NOTES

1. Molex recommends that an extra perishable tooling kit be maintained at your facility.
2. Verify tooling alignment by manually cycling the press and applicator before crimping under power. Check that all screws are tight.
3. Slugs, terminals, dirt and oil should be kept clear of the work area.
4. Wear safety glasses at all times.
5. For recommended maintenance, refer to the FineAdjust manual.

CAUTION: This applicator should only be used in a press with a shut height of 135.8mm (5.346"). Tooling damage could result at a lower setting.

CAUTION: To prevent injury, never operate this applicator without the guards supplied with the press or wire-processing machine in place. Reference the press or wire processing manufacturer's instruction manual.

CAUTION: Molex crimp specifications are valid only when used with Molex terminals, applicators and tooling.

Application Tooling Support

Phone: (402) 458-TOOL (8665)

E-Mail: applicationtooling@molex.com

Website: www.molex.com/applicationtooling

Molex is a registered trademark of Molex, LLC in the United States of America and may be registered in other countries; all other trademarks listed herein belong to their respective owners.