

Silicon Standard Recovery Diode

$V_{RRM} = 200\text{ V} - 1000\text{ V}$

$I_F = 150\text{ A}$

Features

- High Surge Capability
- Types from 200 V to 1000 V V_{RRM}
- Not ESD Sensitive

Note:

1. Standard polarity: Stud is cathode.
2. Reverse polarity (R): Stud is anode.
3. Stud is base.

DO-8 Package



Maximum ratings, at $T_j = 25\text{ }^\circ\text{C}$, unless otherwise specified ("R" devices have leads reversed)

Parameter	Symbol	Conditions	150K(R)20A	150K(R)40A	150K(R)60A	150K(R)80A	150K(R)100A	Unit
Repetitive peak reverse voltage	V_{RRM}		200	400	600	800	1000	V
DC blocking voltage	V_{DC}		200	400	600	800	1000	V
Continuous forward current	I_F	$T_C \leq 110\text{ }^\circ\text{C}$	150	150	150	150	150	A
Surge non-repetitive forward current, Half Sine Wave	$I_{F,SM}$	$T_C = 25\text{ }^\circ\text{C}$, $t_p = 8.3\text{ ms}$	3740	3740	3740	3740	3740	A
I_2t for fusing	I_2t	$t = 8.3\text{ms}$	58000	58000	58000	58000	58000	A^2sec
Operating temperature	T_j		-55 to 150	-55 to 150	-55 to 150	-55 to 150	-55 to 150	$^\circ\text{C}$
Storage temperature	T_{stg}		-55 to 150	-55 to 150	-55 to 150	-55 to 150	-55 to 150	$^\circ\text{C}$

Electrical characteristics, at $T_j = 25\text{ }^\circ\text{C}$, unless otherwise specified

Parameter	Symbol	Conditions	150K(R)20A	150K(R)40A	150K(R)60A	150K(R)80A	150K(R)100A	Unit
Diode forward voltage	V_F	$I_F = 150\text{ A}$, $T_j = 25\text{ }^\circ\text{C}$	1.33	1.33	1.33	1.33	1.33	V
Reverse current	I_R	$V_R = V_{RRM}$, $T_j = 175\text{ }^\circ\text{C}$	35	35	35	32	24	mA

Thermal characteristics

Parameter	Symbol	Conditions	150K(R)20A	150K(R)40A	150K(R)60A	150K(R)80A	150K(R)100A	Unit
Thermal resistance, junction - case	R_{thJC}		0.25	0.25	0.25	0.25	0.25	$^\circ\text{C/W}$

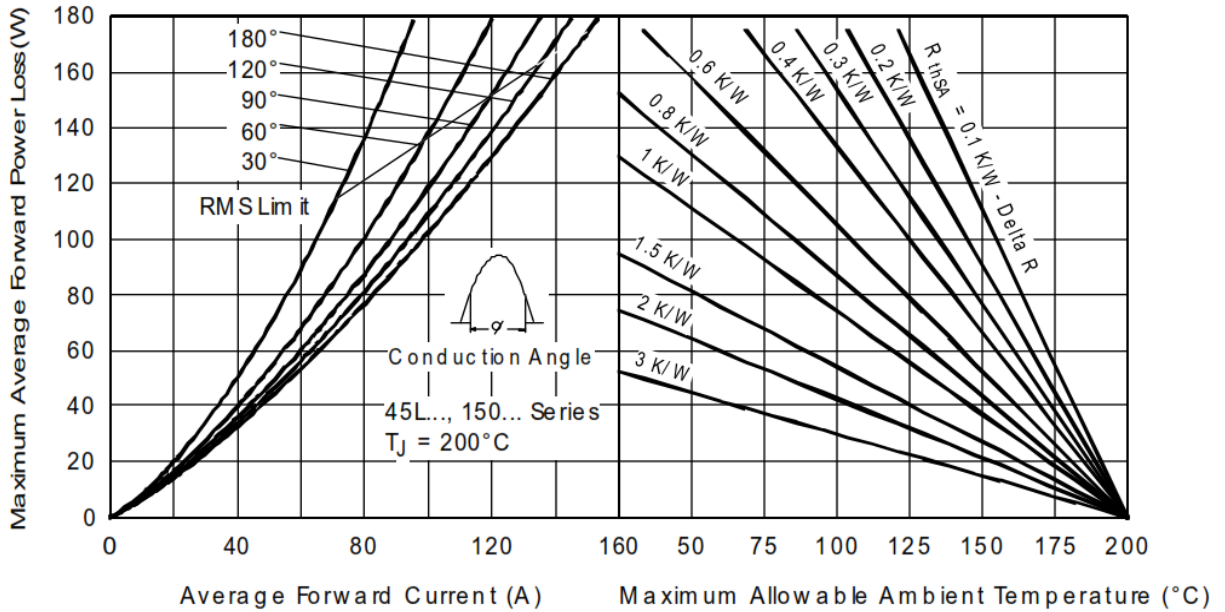
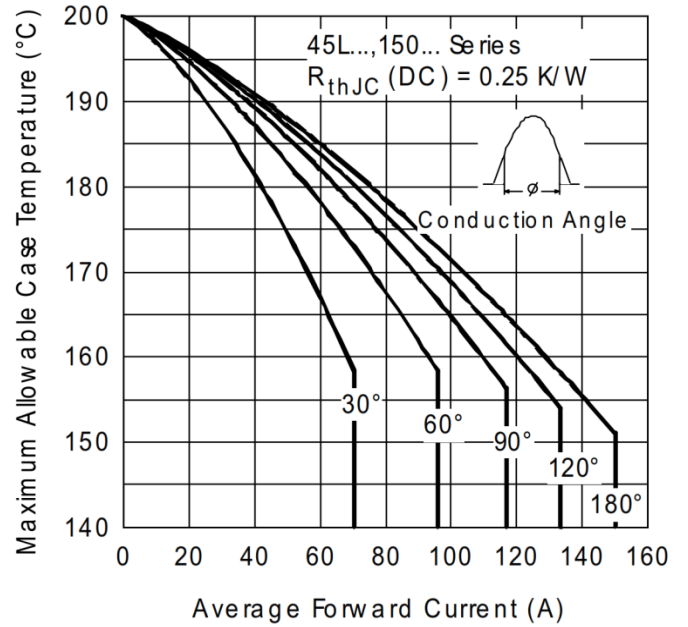
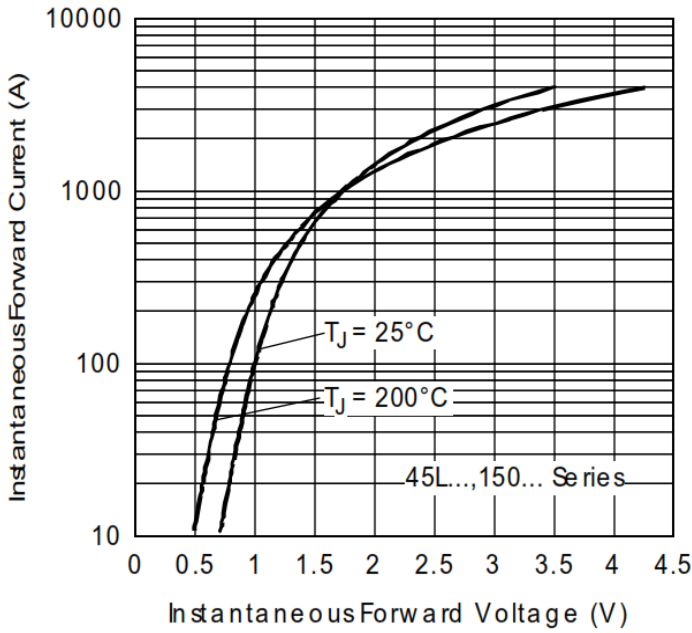

Package dimensions and terminal configuration

Product is marked with part number and terminal configuration.

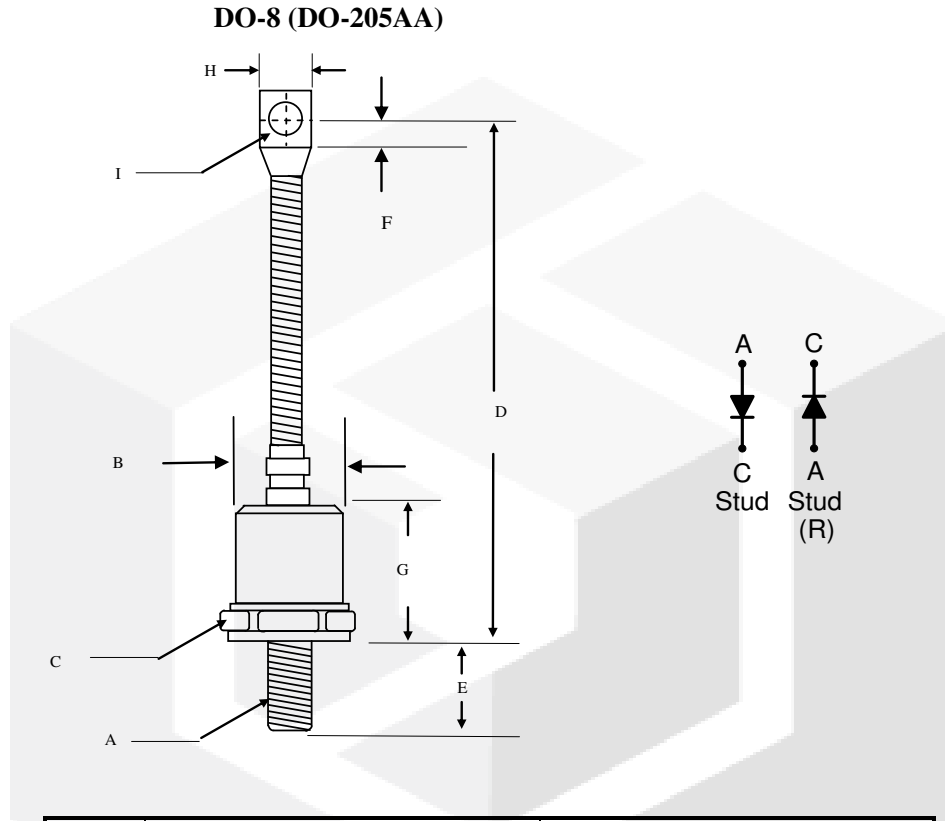

	Inches		Millimeters	
	Min	Max	Min	Max
A	3/8-24 UNF			
B	----	φ0.930	----	φ23.5
C	1.050	1.060	26.67	26.92
D	4.300	4.700	109.22	119.38
E	----	0.690	----	17.00
F	0.260	----	6.50	----
G	----	0.940	----	24.00
H	----	0.600	----	15.23
I	0.276	0.286	7.010	7.260