



# 8-Chan JFET Analog Multiplexers (Overvoltage & Power Supply Loss Protected)

## MUX-08

### FEATURES

- JFET Switches Rather Than CMOS
- Low "ON" Resistance ..... 220Ω Typ
- Highly Resistant to Static Discharge Damage
- No SCR Latch-Up Problems
- Digital Inputs Compatible With TTL and CMOS
- 125°C Temperature Tested Dice Available
- MUX-08 Pin Compatible With DG508, HI-508A, IH5108, IH6108, LF11508/12508/13508, AD7506
- MUX-24 is Obsolete

### ORDERING INFORMATION †

| 25°C ON RESISTANCE | PACKAGE       |                |                | OPERATING TEMPERATURE RANGE |
|--------------------|---------------|----------------|----------------|-----------------------------|
|                    | CERDIP 16-PIN | PLASTIC 16-PIN | LCC 20-CONTACT |                             |
| 220Ω               | MUX08AQ*      | —              | —              | MIL                         |
|                    | MUX08EQ       | —              | —              | IND                         |
|                    | —             | MUX08EP        | —              | COM                         |
| 300Ω               | MUX08BQ*      | —              | MUX08BRC/883   | MIL                         |
|                    | MUX08FQ       | —              | —              | IND                         |
|                    | —             | MUX08FP        | —              | XIND                        |
|                    | —             | MUX08FS††      | —              | XIND                        |

\* For devices processed in total compliance to MIL-STD-883, add /883 after part number. Consult factory for 883 data sheet.

† Burn-in is available on commercial and industrial temperature range parts in CerDIP, plastic DIP, and TO-can packages.

†† For availability and burn-in information on SO and PLCC packages, contact your local sales office.

### GENERAL DESCRIPTION

The MUX-08 is a monolithic eight-channel analog multiplexer which connects a single output to one of the eight analog inputs depending upon the state of a 3-bit binary address.

The MUX-24 is a monolithic four-channel differential analog multiplexer configured in a double pole, four-position (plus OFF) electronic switch array. A two-bit binary input address connects a pair of independent analog inputs from each four-channel input section to the corresponding pair of independent analog outputs.

All switches in the MUX-08/MUX-24 are turned OFF by applying logic "0" to the ENABLE pin, thereby providing a package select function.

### REV. B

Information furnished by Analog Devices is believed to be accurate and reliable. However, no responsibility is assumed by Analog Devices for its use, nor for any infringements of patents or other rights of third parties which may result from its use. No license is granted by implication or otherwise under any patent or patent rights of Analog Devices.

Fabricated with Precision Monolithics' high performance Bipolar-JFET technology, these devices offer low, constant "ON" resistance, low leakage currents and fast settling time with low crosstalk to satisfy a wide variety of applications. These multiplexers do not suffer from latch-up or static charge blow-out problems associated with similar CMOS parts. The digital inputs are designed to operate from both TTL and CMOS levels while always providing a definite break-before-make action without the need for external pull-up resistors over the full operating temperature range.

The MUX-24 is no longer available.

### PIN CONNECTIONS

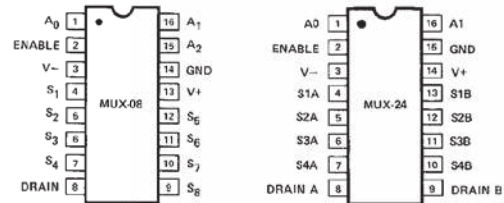

16-PIN CERDIP (Q-Suffix)

16-PIN PLASTIC DIP (P-Suffix)

16-PIN SO (S-Suffix)

20-CONTACT LCC (RC-Suffix)

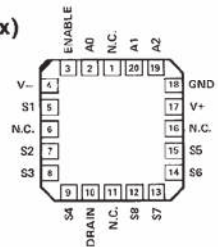

### FUNCTIONAL DIAGRAMS

MUX-08

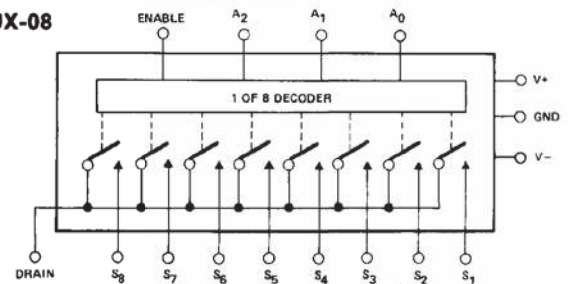

MUX-24

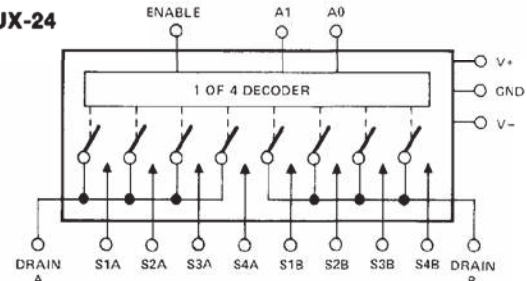

One Technology Way, P.O. Box 9106, Norwood, MA 02062-9106, U.S.A.  
Tel: 617/329-4700 Fax: 617/326-8703 Twx: 710/394-6577  
Telex: 924491 Cable: ANALOG NORWOODMASS

# MUX08\* PRODUCT PAGE QUICK LINKS

Last Content Update: 02/23/2017

---

## COMPARABLE PARTS

View a parametric search of comparable parts.

## DOCUMENTATION

### Application Notes

- AN-1024: How to Calculate the Settling Time and Sampling Rate of a Multiplexer
- AN-32: Single Supply Operation of JFET Multiplexers

### Data Sheet

- MUX08: Military Data Sheet
- MUX08: 8-Chan Analog Multiplexers (Overvoltage & Power Supply Loss Protected) Data Sheet

## DESIGN RESOURCES

- MUX08 Material Declaration
- PCN-PDN Information
- Quality And Reliability
- Symbols and Footprints

## DISCUSSIONS

View all MUX08 EngineerZone Discussions.

## SAMPLE AND BUY

Visit the product page to see pricing options.

## TECHNICAL SUPPORT

Submit a technical question or find your regional support number.

## DOCUMENT FEEDBACK

Submit feedback for this data sheet.

# MUX-08

## ABSOLUTE MAXIMUM RATINGS (Note 1)

### Operating Temperature Range

|                       |                 |
|-----------------------|-----------------|
| MUX-08/24-AQ, BQ, BRC | -55°C to +125°C |
| MUX-02/24-EQ, FQ      | -25°C to +85°C  |
| MUX-08/24-EP          | 0°C to +70°C    |
| MUX-08/24-FP, FS      | -40°C to +85°C  |

Junction Temperature (T<sub>J</sub>) ..... -65°C to +150°C

Storage Temperature Range ..... -65°C to +150°C

P-Suffix ..... -65°C to +125°C

Lead Temperature (Soldering, 60 sec) ..... 300°C

Maximum Junction Temperature ..... 150°C

V+ Supply to V- Supply ..... 36V

Logic Input Voltage ..... (-4V or V-) to V+ Supply

Analog Input Voltage ..... V- Supply -20V to V+ Supply +20V

Maximum Current Through Any Pin ..... 25mA

| PACKAGE TYPE            | θ <sub>JA</sub> (Note 2) | θ <sub>JC</sub> | UNITS |
|-------------------------|--------------------------|-----------------|-------|
| 16-Pin Hermetic DIP (Q) | 100                      | 16              | °C/W  |
| 16-Pin Plastic DIP (P)  | 82                       | 39              | °C/W  |
| 20-Contact LCC (RC)     | 98                       | 38              | °C/W  |
| 16-Pin SO (S)           | 111                      | 35              | °C/W  |

### NOTES:

1. Absolute maximum ratings apply to both DICE and packaged parts, unless otherwise noted.
2. θ<sub>JA</sub> is specified for worst case mounting conditions, i.e., θ<sub>JA</sub> is specified for device in socket for CerDIP, P-DIP, and LCC packages; θ<sub>JA</sub> is specified for device soldered to printed circuit board for SO package.

## ELECTRICAL CHARACTERISTICS at V+ = +15V, V- = -15V and T<sub>A</sub> = 25°C, unless otherwise noted.

| PARAMETER   | SYMBOL                                    | CONDITIONS  | MUX-08A/E<br>MUX-24A/E |                   |             | MUX-08B/F<br>MUX-24B/F |                   |             | UNITS |
|---|---|---|------------------------|-------------------|-------------|------------------------|-------------------|-------------|-------|
|   |   |   | MIN                    | TYP               | MAX         | MIN                    | TYP               | MAX         |       |
| "ON" Resistance   | R <sub>ON</sub>                           | V <sub>S</sub> ≤ 10V, I <sub>S</sub> ≤ 200μA                | —                      | 220               | 300         | —                      | 300               | 400         | Ω     |
| ΔR <sub>ON</sub> With Applied Voltage                               | ΔR <sub>ON</sub>                          | -10V ≤ V <sub>S</sub> ≤ 10V, I <sub>S</sub> = 200μA         | —                      | 1                 | 5           | —                      | 3                 | 7           | %     |
| R <sub>ON</sub> Match Between Switches                              | R <sub>ON</sub> Match                     | V <sub>S</sub> = 0V, I <sub>S</sub> = 200μA                 | —                      | 7                 | 15          | —                      | 9                 | 20          | %     |
| Analog Voltage Range  | V <sub>A</sub>                            | (Note 6)  | +10<br>-10             | +10.4<br>-15      | —           | +10<br>-10             | +10.4<br>-15      | —           | V     |
| Source Current (Switch "OFF")                                       | I <sub>S(OFF)</sub>                       | V <sub>S</sub> = 10V, V <sub>D</sub> = -10V (Note 1)        | —                      | 0.01              | 1.0         | —                      | 0.01              | 2.0         | nA    |
| Drain Current (Switch "OFF")  | I <sub>D(OFF)</sub>                       | V <sub>S</sub> = 10V, V <sub>D</sub> = -10V (Note 1)        | MUX-08<br>MUX-24       | —<br>0.05         | 0.1<br>1.0  | —                      | 0.1<br>0.05       | 2.0<br>2.0  | nA    |
| Leakage Current (Switch "ON")                                       | I <sub>D(ON)</sub><br>+I <sub>S(ON)</sub> | V <sub>D</sub> = 10V (Note 1)                               | MUX-08<br>MUX-24       | —<br>0.05         | 0.1<br>1.0  | —                      | 0.1<br>0.05       | 2.0<br>2.0  | nA    |
| Digital Input Current   | I <sub>IN</sub>                           | V <sub>IN</sub> = 0.4V to 15V                               | —                      | 1                 | 10          | —                      | 1                 | 10          | μA    |
| Digital "0" Enable Current  | I <sub>INL(EN)</sub>                      | V <sub>EN</sub> = 0.4V                                      | —                      | 4                 | 10          | —                      | 4                 | 10          | μA    |
| Digital Input Capacitance   | C <sub>DIG</sub>                          |   | —                      | 3                 | —           | —                      | 3                 | —           | pF    |
| Switching Time (t <sub>TRAN</sub> )                                 | t <sub>PHL</sub><br>t <sub>PLH</sub>      | (Notes 2, 5) Figure 1<br>(Test Circuit)                     | —                      | 1.5<br>1.0        | 2.1<br>1.3  | —                      | 1.5<br>1.0        | 2.1<br>1.3  | μs    |
| Output Settling Time  | t <sub>S</sub>                            | 10V Step to 0.10%<br>10V Step to 0.05%<br>10V Step to 0.02% | —                      | 2.2<br>2.7<br>3.4 | —<br>—<br>— | —                      | 2.2<br>2.7<br>3.4 | —<br>—<br>— | μs    |
| Break-Before-Make Delay   | t <sub>OPEN</sub>                         | Figure 3 (Test Circuit)                                     | —                      | 0.8               | —           | —                      | 1.0               | —           | μs    |
| Enable Delay "ON"   | t <sub>ON(EN)</sub>                       | (Note 5) Figure 2<br>(Test Circuit)                         | —                      | 1                 | 2           | —                      | 1                 | 2           | μs    |
| Enable Delay "OFF"  | t <sub>OFF(EN)</sub>                      | (Note 5) Figure 2<br>(Test Circuit)                         | MUX-08<br>MUX-24       | —<br>0.2          | 0.1<br>0.5  | 0.4<br>0.5             | —<br>0.3          | 0.2<br>0.6  | μs    |
| "OFF" Isolation   | ISO <sub>OFF</sub>                        | (Note 4) Figure 5<br>(Test Circuit)                         | MUX-08<br>MUX-24       | —<br>66           | 60<br>—     | —<br>—                 | 60<br>66          | —<br>—      | dB    |
| Crosstalk   | CT  | (Note 3) Figure 4<br>(Test Circuit)                         | MUX-08<br>MUX-24       | —<br>76           | 70<br>—     | —<br>—                 | 70<br>76          | —<br>—      | dB    |
| Source Capacitance  | C <sub>S(OFF)</sub>                       | Switch "OFF",<br>V <sub>S</sub> = 0V, V <sub>D</sub> = 0V   | MUX-08<br>MUX-24       | —<br>2            | 2.5<br>—    | —<br>—                 | 2.5<br>2          | —<br>—      | pF    |
| Drain Capacitance   | C <sub>D(OFF)</sub>                       | Switch "OFF",<br>V <sub>S</sub> = 0V, V <sub>D</sub> = 0V   | MUX-08<br>MUX-24       | —<br>4            | 7<br>—      | —<br>—                 | 7<br>4            | —<br>—      | pF    |
| Input to Output Capacitance   | C <sub>DS(OFF)</sub>                      | (Note 4)  | MUX-08<br>MUX-24       | —<br>0.15         | 0.3<br>—    | —<br>—                 | 0.3<br>0.15       | —<br>—      | pF    |
| Positive Supply Current<br>(All Digital Inputs<br>Logic "0" or "1") | I <sub>+</sub>                            | V <sub>+</sub> = 15V<br>V <sub>+</sub> = 5V                 | —                      | 10<br>8           | 12<br>—     | —                      | 6<br>5            | 12<br>—     | mA    |
| Negative Supply Current<br>(All Digital Inputs<br>Logic "0" or "1") | I <sub>-</sub>                            | V <sub>+</sub> = -15V<br>V <sub>+</sub> = -5V               | —                      | 3.0<br>2.5        | 3.8<br>—    | —                      | 2.0<br>1.8        | 3.8<br>—    | mA    |

## ELECTRICAL CHARACTERISTICS at $V_+ = 15V$ , $V_- = -15V$ and $-55^\circ C \leq T_A \leq 125^\circ C$ , unless otherwise noted.

| PARAMETER                            | SYMBOL                       | CONDITIONS                               | MUX-08A/<br>MUX-24A |              |           | MUX-08B/<br>MUX-24B |              |            | UNITS    |
|--------------------------------------|------------------------------|--|---------------------|--------------|-----------|---------------------|--------------|------------|----------|
|                                      |                              |  | MIN                 | TYP          | MAX       | MIN                 | TYP          | MAX        |          |
| "ON" Resistance                      | $R_{ON}$                     | $V_S \leq 10V, I_S \leq 200\mu A$        | —                   | —            | 400       | —                   | —            | 500        | $\Omega$ |
| $\Delta R_{ON}$ With Applied Voltage | $\Delta R_{ON}$              | $-10V \leq V_S \leq 10V, I_S = 200\mu A$ | —                   | 1.5          | —         | —                   | 4.5          | —          | %        |
| $R_{ON}$ Match Between Switches      | $R_{ON}$ Match               | $V_S = 0V, I_S = 200\mu A$               | —                   | 10           | —         | —                   | 15           | —          | %        |
| Analog Voltage Range                 | $V_A$                        | (Note 6)                                 | +10<br>-10          | +10.4<br>-15 | —         | +10<br>-10          | +10.4<br>-15 | —          | V        |
| Source Current (Switch "OFF")        | $I_{S(OFF)}$                 | $V_S = 10V, V_D = -10V$ (Notes 1, 7)     | —                   | —            | 25        | —                   | —            | 50         | nA       |
| Drain Current (Switch "OFF")         | $I_{D(OFF)}$                 | $V_S = 10V, V_D = -10V$<br>(Notes 1, 7)  | MUX-08<br>MUX-24    | —<br>—       | 100<br>50 | —<br>—              | —<br>—       | 500<br>500 | nA       |
| Leakage Current (Switch "ON")        | $I_{D(ON)}$<br>$+ I_{S(ON)}$ | $V_D = 10V$ (Notes 1, 7)                 | MUX-08<br>MUX-24    | —<br>—       | 100<br>50 | —<br>—              | —<br>—       | 500<br>500 | nA       |
| Digital "1" Input Voltage            | $V_{INH}$                    | (Note 6)                                 | 2                   | —            | —         | 2                   | —            | —          | V        |
| Digital "0" Input Voltage            | $V_{INL}$                    | (Note 6)                                 | —                   | —            | 0.7       | —                   | —            | 0.7        | V        |
| Digital Input Current                | $I_{IN}$                     | $V_{IN} = 0.4V$ to 15V                   | —                   | —            | 20        | —                   | —            | 20         | $\mu A$  |
| Digital "0" Enable Current           | $I_{INL(EN)}$                | $V_{EN} = 0.4V$                          | —                   | —            | 20        | —                   | —            | 20         | $\mu A$  |
| Positive Supply Current              | $I_+$                        | All Digital Inputs Logic<br>"0" or "1"   | —                   | —            | 15        | —                   | —            | 15         | mA       |
| Negative Supply Current              | $I_-$                        | All Digital Inputs<br>Logic "0" or "1"   | —                   | —            | 5         | —                   | —            | 5          | mA       |

## ELECTRICAL CHARACTERISTICS at $V_+ = 15V$ , $V_- = -15V$ and $-25^\circ C \leq T_A \leq +85^\circ C$ for MUX-08EQ/FQ and MUX-24EQ/FQ; $0^\circ C \leq T_A \leq +70^\circ C$ for MUX-08EP and MUX-24EP; $-40^\circ C \leq T_A \leq +85^\circ C$ for MUX-08FP/FS and MUX-24FP/FS, unless otherwise noted

| PARAMETER                            | SYMBOL                       | CONDITIONS                               | MUX-08E/<br>MUX-24E |              |           | MUX-08F/<br>MUX-24F |              |           | UNITS    |
|--------------------------------------|------------------------------|--|---------------------|--------------|-----------|---------------------|--------------|-----------|----------|
|                                      |                              |  | MIN                 | TYP          | MAX       | MIN                 | TYP          | MAX       |          |
| "ON" Resistance                      | $R_{ON}$                     | $V_S \leq 10V, I_S \leq 200\mu A$        | —                   | —            | 400       | —                   | —            | 500       | $\Omega$ |
| $\Delta R_{ON}$ With Applied Voltage | $\Delta R_{ON}$              | $-10V \leq V_S \leq 10V, I_S = 200\mu A$ | —                   | 1.5          | —         | —                   | 4.5          | —         | %        |
| $R_{ON}$ Match Between Switches      | $R_{ON}$ Match               | $V_S = 0V, I_S = 200\mu A$               | —                   | 10           | —         | —                   | 15           | —         | %        |
| Analog Voltage Range                 | $V_A$                        | (Note 6)                                 | +10<br>-10          | +10.4<br>-15 | —         | +10<br>-10          | +10.4<br>-15 | —         | V        |
| Source Current (Switch "OFF")        | $I_{S(OFF)}$                 | $V_S = 10V, V_D = -10V$ (Notes 1, 7)     | —                   | —            | 10        | —                   | —            | 10        | nA       |
| Drain Current (Switch "OFF")         | $I_{D(OFF)}$                 | $V_S = 10V, V_D = 10V$<br>(Notes 1, 7)   | MUX-08<br>MUX-24    | —<br>—       | 100<br>50 | —<br>—              | —<br>—       | 100<br>50 | nA       |
| Leakage Current (Switch "ON")        | $I_{D(ON)}$<br>$+ I_{S(ON)}$ | $V_D = 10V$ (Notes 1, 7)                 | MUX-08<br>MUX-24    | —<br>—       | 100<br>50 | —<br>—              | —<br>—       | 100<br>50 | nA       |
| Digital "1" Input Voltage            | $V_{INH}$                    | (Note 6)                                 | 2                   | —            | —         | 2                   | —            | —         | V        |
| Digital "0" Input Voltage            | $V_{INL}$                    | (Note 6)                                 | —                   | —            | 0.8       | —                   | —            | 0.8       | V        |
| Digital Input Current                | $I_{IN}$                     | $V_{IN} = 0.4V$ to 15V                   | —                   | —            | 20        | —                   | —            | 20        | $\mu A$  |
| Digital "0" Enable Current           | $I_{INL(EN)}$                | $V_{EN} = 0.4V$                          | —                   | —            | 20        | —                   | —            | 20        | $\mu A$  |
| Positive Supply Current              | $I_+$                        | All Digital Inputs Logic<br>"0" or "1"   | —                   | —            | 15        | —                   | —            | 15        | mA       |
| Negative Supply Current              | $I_-$                        | All Digital Inputs<br>Logic "0" or "1"   | —                   | —            | 5         | —                   | —            | 5         | mA       |

### NOTES:

- Conditions applied to leakage tests insure worst case leakages. Exceeding 11V on the analog input may cause an "OFF" channel to turn "ON".
- $R_L = 10M\Omega$ ,  $C_L = 10pF$ .
- Crosstalk is measured by driving channel 8 with channel 4 "ON".  
 $R_L = 1M\Omega$ ,  $C_L = 10pF$ ,  $V_S = 5V$  RMS,  $f = 500kHz$ .
- "OFF" isolation is measured by driving channel 8 with ALL channels "OFF".  
 $R_L = 1k\Omega$ ,  $C_L = 10pF$ ,  $V_S = 5V$  RMS,  $f = 500kHz$ .  $C_{DS}$  is computed from the OFF isolation measurement.
- Sample tested.
- Guaranteed by leakage current and  $R_{ON}$  tests.
- Leakage tests are performed only on military temperature grades at  $125^\circ C$ .

# MUX-08

## DICE CHARACTERISTICS (125° C TESTED DICE AVAILABLE)

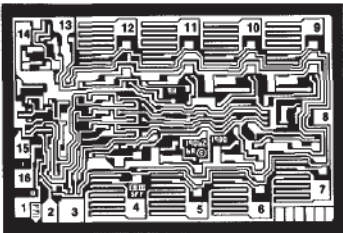

**MUX-08**

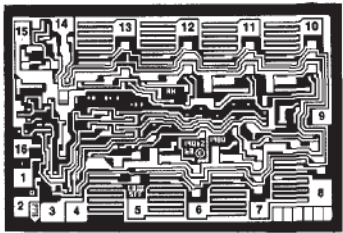

**MUX-24**

**DIE SIZE 0.093 × 0.059 inch, 5487 sq. mils  
(2.362 × 1.500 mm, 3543 sq. mm)**

|  |   |
|--|---|
| <p><b>1. A0</b></p> <p><b>2. ENABLE</b></p> <p><b>3. V- (SUBSTRATE)</b></p> <p><b>4. S1</b></p> <p><b>5. S2</b></p> <p><b>6. S3</b></p> <p><b>7. S4</b></p> <p><b>8. DRAIN</b></p> | <p><b>9. S8</b></p> <p><b>10. S7</b></p> <p><b>11. S6</b></p> <p><b>12. S5</b></p> <p><b>13. V+</b></p> <p><b>14. GND</b></p> <p><b>15. A2</b></p> <p><b>16. A1</b></p> |
|--|---|

|  |  |
|--|--|
| <p><b>1. A0</b></p> <p><b>2. ENABLE</b></p> <p><b>3. V- (SUBSTRATE)</b></p> <p><b>4. S1 A</b></p> <p><b>5. S2 A</b></p> <p><b>6. S3 A</b></p> <p><b>7. S4 A</b></p> <p><b>8. DRAIN A</b></p> | <p><b>9. DRAIN B</b></p> <p><b>10. S4 B</b></p> <p><b>11. S3 B</b></p> <p><b>12. S2 B</b></p> <p><b>13. S1 B</b></p> <p><b>14. V+</b></p> <p><b>15. GND</b></p> <p><b>16. A1</b></p> |
|--|--|

**WAFER TEST LIMITS** at  $V+ = 15V$ ,  $V- = -15V$ ,  $T_A = 25^\circ C$ , unless otherwise noted. (Note 1)

| PARAMETER   | SYMBOL        | CONDITIONS  | MUX-08/<br>MUX-24NT<br>LIMIT | MUX-08/<br>MUX-24N<br>LIMIT | MUX-08/<br>MUX-24G<br>LIMIT | UNITS        |
|---|---------------|---|------------------------------|-----------------------------|-----------------------------|--------------|
| "ON" Resistance   | $R_{ON}$      | $V_S = 0V$ ,<br>$I_S = 200\mu A$<br>$T_A = 125^\circ C$ | 300<br>400                   | 300<br>—                    | 400<br>—                    | $\Omega$ MAX |
| Digital "1" Input Voltage                                 | $V_{INH}$     | (Note 2)  | 2                            | 2                           | 2                           | V MIN        |
| Digital "0" Input Voltage                                 | $V_{INL}$     | (Note 2)  | 0.8                          | 0.8                         | 0.8                         | V MAX        |
| Digital "0" Input Current                                 | $I_{INL}$     | $V_{IN} = 0.4V$<br>$T_A = 125^\circ C$                  | 10<br>20                     | 10<br>—                     | 10<br>—                     | $\mu A$ MAX  |
| Digital "0" Enable Current                                | $I_{INL(EN)}$ | $V_{IN} = 0.4V$<br>$T_A = 125^\circ C$                  | 10<br>20                     | 10<br>—                     | 10<br>—                     | $\mu A$ MAX  |
| Positive Supply Current<br>(All Digital Inputs Logic "0") | $I+$          | $T_A = 125^\circ C$                                     | 12<br>15                     | 12<br>—                     | 12<br>—                     | mA MAX       |
| Negative Supply Current<br>(All Digital Inputs Logic "0") | $I-$          | $T_A = 125^\circ C$                                     | 3.8<br>5                     | 3.8<br>—                    | 3.8<br>—                    | mA MAX       |
| Analog Input Range  | $V_A$         | (Note 2)  | $\pm 10$                     | $\pm 10$                    | $\pm 10$                    | V MIN        |

**NOTE:**

Electrical tests are performed at wafer probe to the limits shown. Due to variations in assembly methods and normal yield loss, yield after packaging is not guaranteed for standard product dice. Consult factory to negotiate specifications based on dice lot qualification through sample lot assembly and testing.

**TYPICAL ELECTRICAL CHARACTERISTICS** at  $V+ = 15V$ ,  $V- = -15V$  and  $T_A = 25^\circ C$  for MUX-08/24N & G,  $T_A = 125^\circ C$  for MUX-08/24NT, unless otherwise noted.

| PARAMETER                            | SYMBOL          | CONDITIONS                                  | MUX-08/<br>MUX-24NT<br>TYPICAL | MUX-08/<br>MUX-24N<br>TYPICAL | MUX-08/<br>MUX-24G<br>TYPICAL | UNITS   |
|--------------------------------------|-----------------|---|--------------------------------|-------------------------------|-------------------------------|---------|
| Switching Time ( $t_{TRAN}$ )        | $t_{PHL}$       | (Note 1)                                    | 1.7                            | 1.3                           | 2.1                           | $\mu S$ |
|                                      | $t_{PLH}$       | (Note 1)                                    | 1.1                            | 0.9                           | 1.3                           | $\mu S$ |
| Output Settling Time                 | $t_S$           | 10V Step to 0.1% (Note 1)                   | 2.1                            | 1.5                           | 1.9                           | $\mu S$ |
| Break-Before-Make Delay              | $t_{OPEN}$      | (Note 1)                                    | 0.8                            | 0.8                           | 1.0                           | $\mu S$ |
| Crosstalk                            | CT              | (Note 1)                                    | 70                             | 70                            | 70                            | dB      |
| $\Delta R_{ON}$ With Applied Voltage | $\Delta R_{ON}$ | $-10V \leq V_S \leq 10V$ , $I_S = 200\mu A$ | 2                              | 2                             | 6                             | %       |
| Leakage Current (Switch "ON")        | $I_{D(ON)}$     | $V_D = 10V$ (Note 1)                        | 20                             | 0.5                           | 0.5                           | nA      |
| Analog Input Range                   | $V_A$           |   | +10.4/-15                      | +10.4/-15                     | +10.4/-15                     | V       |

**NOTES:**

1. The data shown is extrapolated from measurements made on the packaged devices.

2. Guaranteed by leakage current and  $R_{ON}$  tests.

## MUX-08 LOGIC STATE

| A <sub>2</sub> | A <sub>1</sub> | A <sub>0</sub> | EN | "ON" CHANNEL |
|----------------|----------------|----------------|----|--------------|
| X              | X              | X              | L  | NONE         |
| L              | L              | L              | H  | 1            |
| L              | L              | H              | H  | 2            |
| L              | H              | L              | H  | 3            |
| L              | H              | H              | H  | 4            |
| H              | L              | L              | H  | 5            |
| H              | L              | H              | H  | 6            |
| H              | H              | L              | H  | 7            |
| H              | H              | H              | H  | 8            |

## MUX-24 LOGIC STATE

| A <sub>1</sub> | A <sub>0</sub> | EN | "ON" CHANNEL |
|----------------|----------------|----|--------------|
| X              | X              | L  | NONE         |
| L              | L              | H  | 1            |
| L              | H              | H  | 2            |
| H              | L              | H  | 3            |
| H              | H              | H  | 4            |

### TYPICAL PERFORMANCE CHARACTERISTICS (Applies to all grades, unless otherwise noted.)

#### MUX-08 BREAK-BEFORE-MAKE SWITCHING

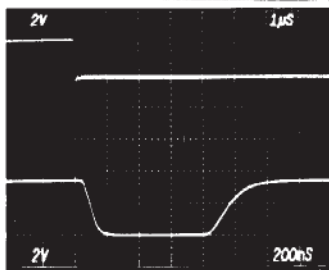

R<sub>L</sub> = 1kΩ, C<sub>L</sub> = 10pF, V<sub>1</sub> = 10V  
VOLTAGE = 2V/DIV  
TIME = 200ns/DIV

#### MUX-08 LARGE-SIGNAL SWITCHING

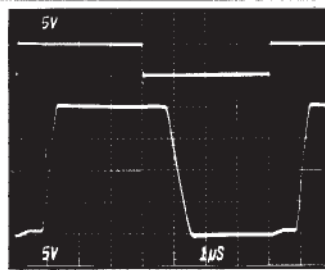

R<sub>L</sub> = 1MΩ, C<sub>L</sub> = 10pF, V<sub>1</sub> = -10V, V<sub>8</sub> = +10V  
VOLTAGE = 5V/DIV  
TIME = 1µs/DIV

#### MUX-08 SMALL-SIGNAL SWITCHING

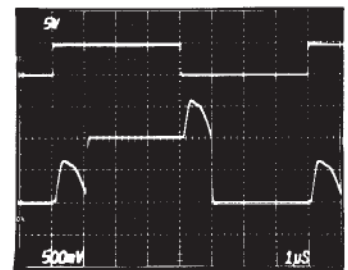

R<sub>L</sub> = 1MΩ, C<sub>L</sub> = 10pF, V<sub>1</sub> = -500mV, V<sub>8</sub> = +500mV  
VOLTAGE = 500mV/DIV  
TIME = 1µs/DIV

#### MUX-08 SMALL-SIGNAL SWITCHING WITH FILTERING

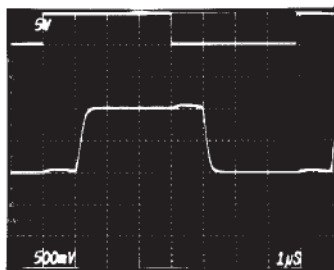

R<sub>L</sub> = 1MΩ, C<sub>L</sub> = 500pF, V<sub>1</sub> = 500mV, V<sub>8</sub> = +500mV  
VOLTAGE = 500mV/DIV  
TIME = 1µs/DIV

#### MUX-08 SMALL-SIGNAL SWITCHING WITH 2µs SAMPLE TIME

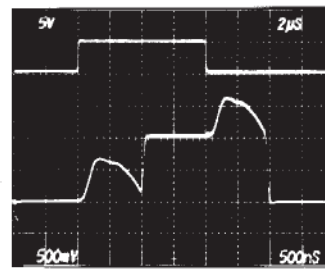

R<sub>L</sub> = 1MΩ, C<sub>L</sub> = 10pF, V<sub>1</sub> = -500mV, V<sub>8</sub> = +500mV  
VOLTAGE = 500mV/DIV  
TIME = 500ns/DIV

#### MUX-08 SMALL-SIGNAL SWITCHING WITH FILTERING AND 2.5µs SAMPLE TIME

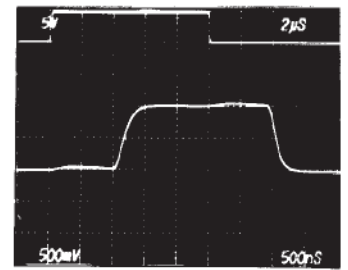

R<sub>L</sub> = 1MΩ, C<sub>L</sub> = 500pF, V<sub>1</sub> = -500mV, V<sub>8</sub> = +500mV  
VOLTAGE = 500mV/DIV  
TIME = 500ns/DIV

#### NOTE:

Top waveforms: Digital Input 5V/DIV  
Bottom waveforms: Multiplexer Output

# MUX-08

TYPICAL PERFORMANCE CHARACTERISTICS (Applies to all grades, unless otherwise noted.)

**MUX-08 CROSSTALK AND OFF ISOLATION PERFORMANCE OF CHANNEL 8**

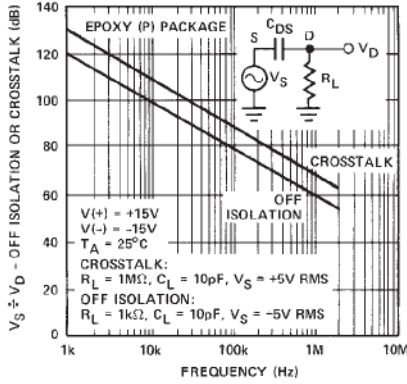

**MUX-08 CROSSTALK AND OFF ISOLATION PERFORMANCE OF CHANNEL 8**

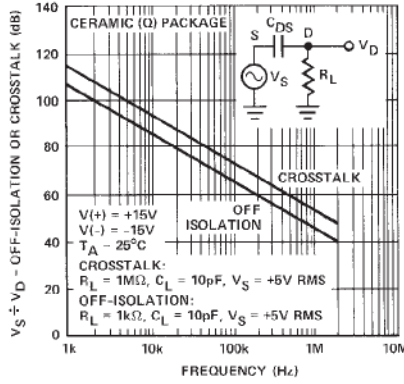

**TRANSITION TIMES vs TEMPERATURE**

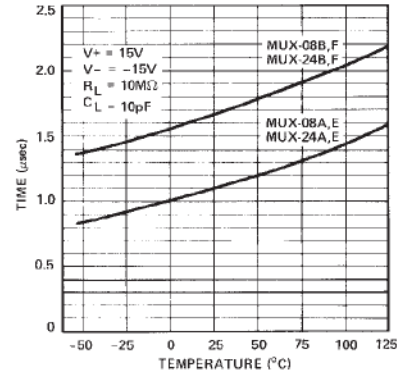

**ENABLE DELAY TIMES vs TEMPERATURE**

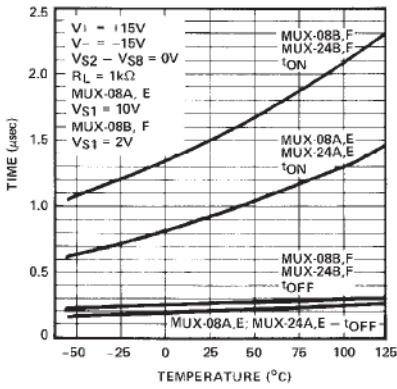

**"ON" RESISTANCE ( $R_{ON}$ ) vs ANALOG VOLTAGE ( $V_A$ )**

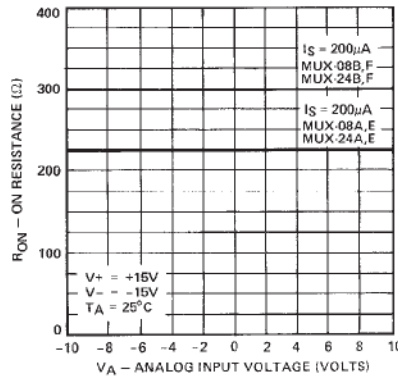

**$R_{ON}$  vs SWITCH VOLTAGE ( $V_{SD}$ )**

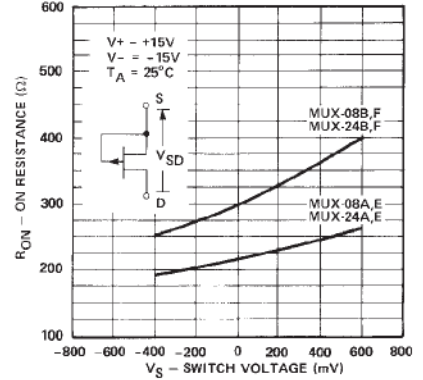

**$R_{ON}$  vs SWITCH CURRENT ( $I_S$ )**

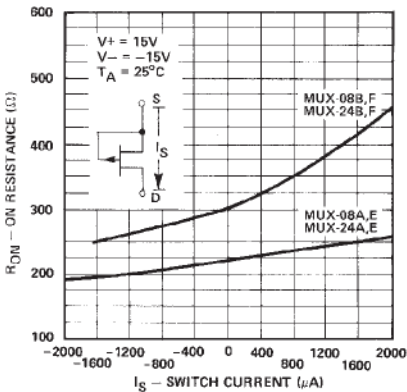

**$R_{ON}$  vs TEMPERATURE**

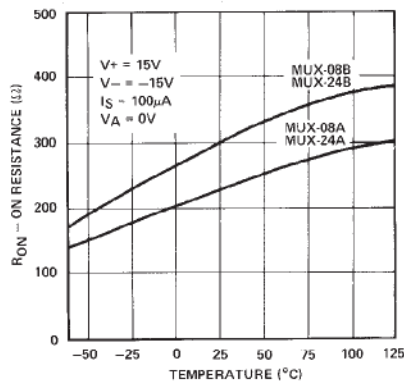

**SWITCH LEAKAGE CURRENTS vs ANALOG INPUT VOLTAGE**

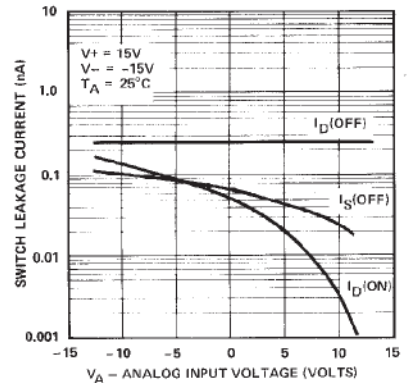

## TYPICAL PERFORMANCE CHARACTERISTICS (Applies to all grades, unless otherwise noted.)

### SWITCH LEAKAGE CURRENTS vs TEMPERATURE

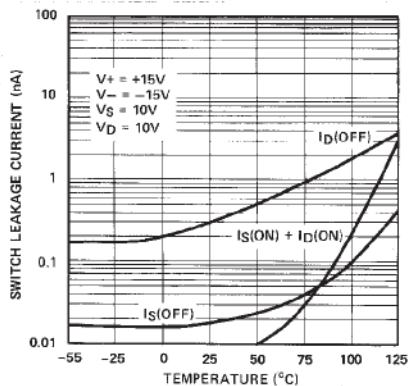

### SUPPLY CURRENTS vs TEMPERATURE

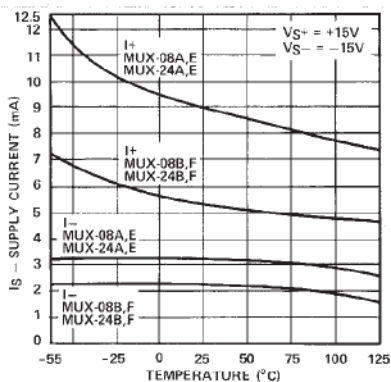

### MUX-08 SWITCH CAPACITANCES vs ANALOG INPUT VOLTAGE

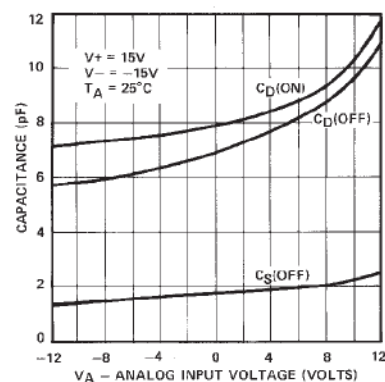

### MUX-24 SMALL-SIGNAL SWITCHING

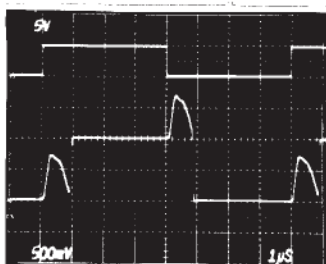

$R_L = 1M\Omega$ ,  $C_L = 10pF$ ,  $V_1 = -500mV$ ,  
 $V_4 = +500mV$   
 VOLTAGE = 500mV/DIV, TIME = 1 $\mu$ S/DIV

### MUX-24 SMALL-SIGNAL SWITCHING WITH FILTERING

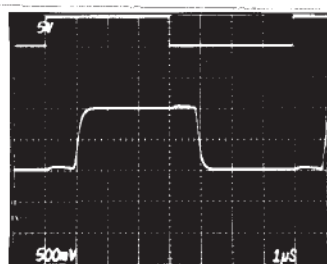

$R_L = 1M\Omega$ ,  $C_L = 500pF$ ,  $V_1 = -500mV$ ,  
 $V_4 = +500mV$   
 VOLTAGE = 500mV/DIV, TIME = 1 $\mu$ S/DIV

### MUX-24 SMALL-SIGNAL SWITCHING WITH 2 $\mu$ S SAMPLE TIME

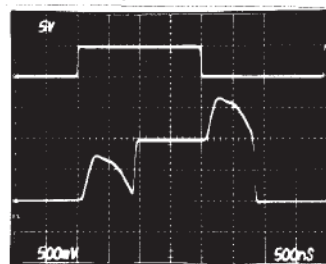

$R_L = 1M\Omega$ ,  $C_L = 10pF$ ,  $V_1 = -500mV$ ,  
 $V_4 = +500mV$   
 VOLTAGE = 500mV/DIV, TIME = 500ns/DIV

### MUX-24 SMALL-SIGNAL SWITCHING WITH FILTERING AND 2.5 $\mu$ S SAMPLE TIME

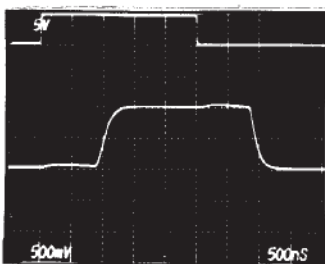

$R_L = 1M\Omega$ ,  $C_L = 500pF$ ,  $V_1 = -500mV$ ,  
 $V_4 = +500mV$   
 VOLTAGE = 500mV/DIV, TIME = 500ns/DIV

### MUX-24 BREAK-BEFORE-MAKE SWITCHING

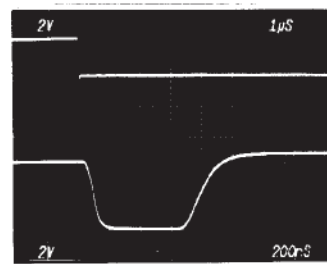

$R_L = 1k\Omega$ ,  $C_L = 10pF$ ,  $V_1 = 10V$   
 VOLTAGE = 2V/DIV, TIME = 200ns/DIV

### MUX-24 LARGE-SIGNAL SWITCHING

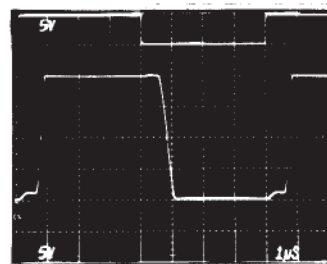

$R_L = 1M\Omega$ ,  $C_L = 10pF$ ,  $V_1 = -10V$ ,  $V_4 = +10V$   
 VOLTAGE = 5V/DIV, TIME = 1 $\mu$ S/DIV

#### NOTE:

Top waveforms: Digital Input 5V/DIV  
 Bottom waveforms: Multiplexer Output



# MUX-08

TYPICAL PERFORMANCE CHARACTERISTICS (Applies to all grades, unless otherwise noted.)

**DIGITAL INPUT CURRENTS vs TEMPERATURE**

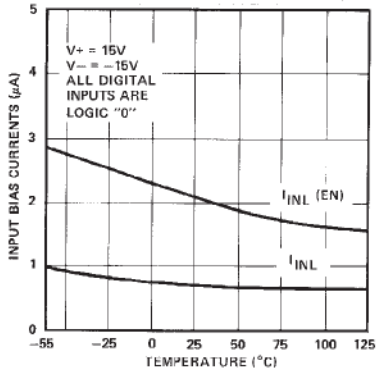

**MUX-24 SWITCH CAPACITANCES vs ANALOG INPUT VOLTAGE**

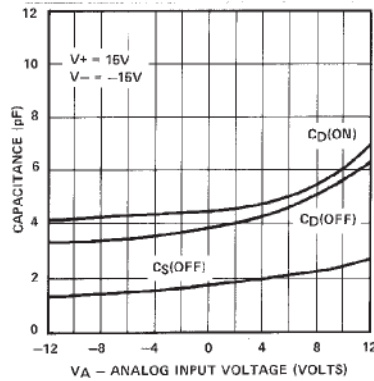

**MUX-24 CROSSTALK AND OFF ISOLATION PERFORMANCE OF CHANNEL 3A**

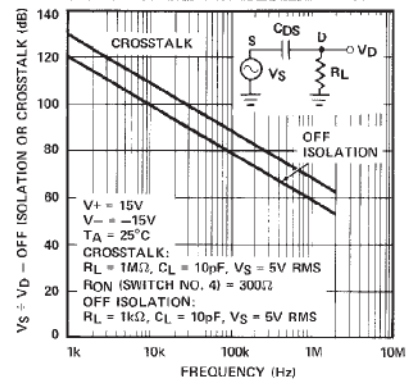

## A.C. TEST CIRCUITS

**TRANSITION TIME TEST CIRCUIT**

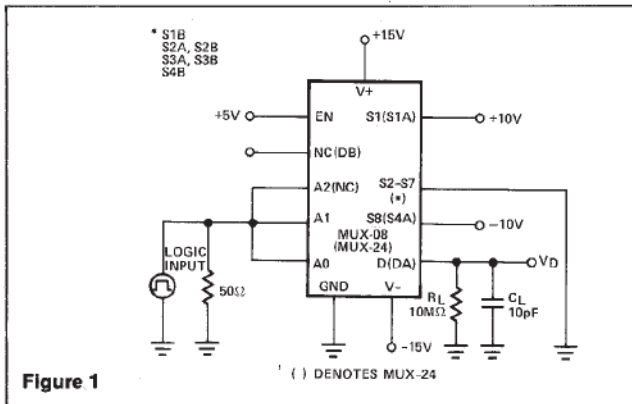

Figure 1

**BREAK-BEFORE-MAKE TEST CIRCUIT**

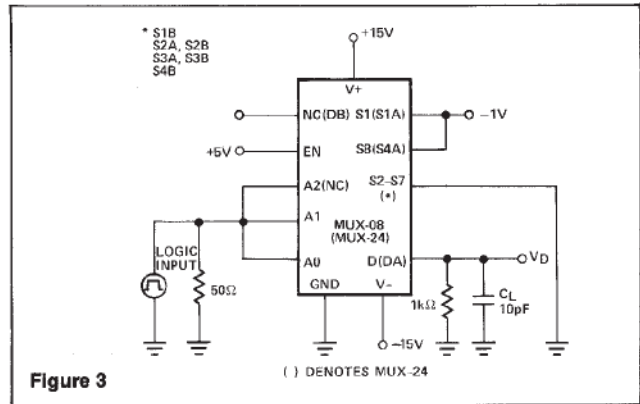

Figure 3

**ENABLE DELAY TIME TEST CIRCUIT**

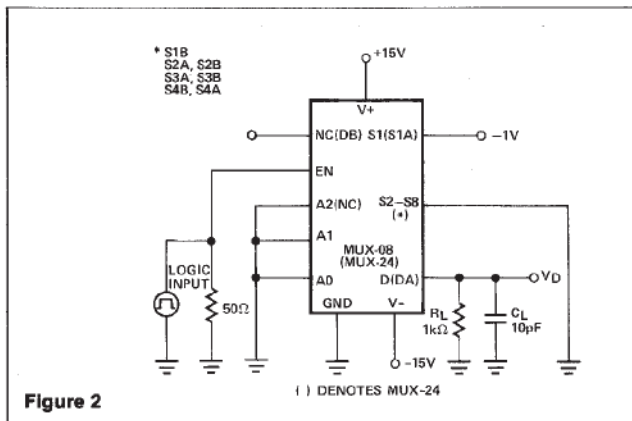

Figure 2

**CROSSTALK MEASUREMENT CIRCUIT**

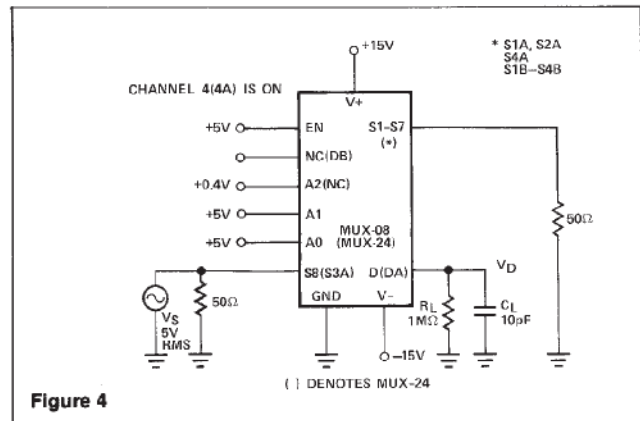

Figure 4

A.C. TEST CIRCUITS

OFF-ISOLATION MEASUREMENT CIRCUIT

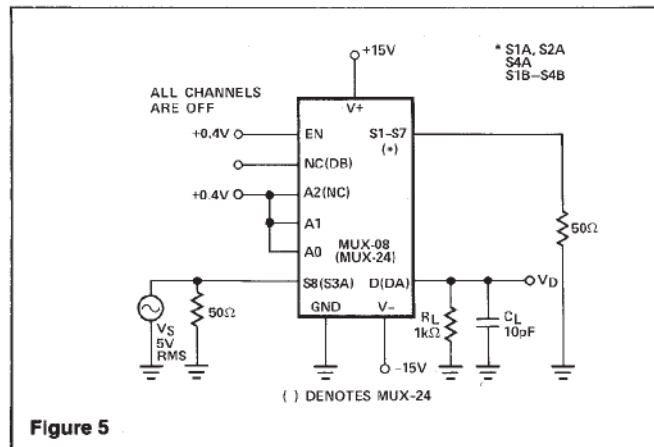
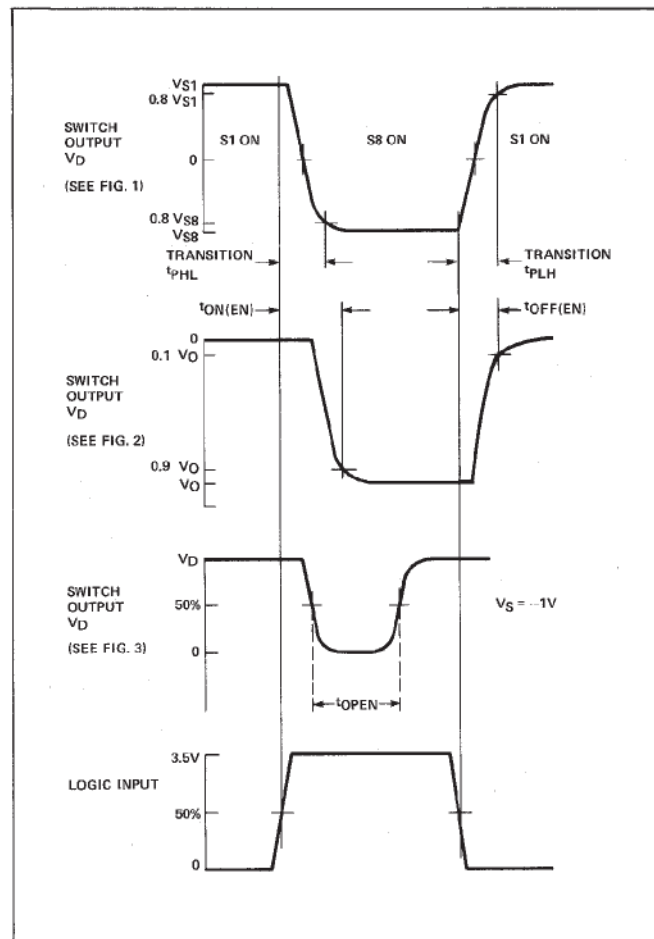

Figure 5

SWITCHING TIME WAVEFORMS



APPLICATIONS INFORMATION

These analog multiplexers employ ion-implanted JFETs in a switch configuration designed to assure break-before-make action. The turn-off time is much faster than the turn-on time to guarantee this feature over the full operating temperature and input voltage range. Fabricated with Bipolar-JFET processing, **special handling as required with CMOS devices, is not necessary to prevent damage to this multiplexer.** Because the digital inputs only require a 2.0V logic "1" input level, power-consuming pull-up resistors are not required for TTL compatibility to insure break-make switching as is most often the case with CMOS multiplexers. The digital inputs utilize PNP input transistors where input current is maximum at the logic "0" level and drops to that of a reverse-biased diode (about 10nA) as the input voltage is raised above  $\approx 1.4V$ .

The "ON" resistance,  $R_{ON}$ , of the analog switches is constant over the wide input voltage range of  $-15V$  to  $+11V$  with  $V_{SUPPLY} = \pm 15V$ . Higher input voltage is tolerable provided that some form of current limiting is employed (such as that of an op-amp output stage) to avoid exceeding junction temperature and power dissipation requirements. For normal operation, however, positive input voltages should be restricted to 11V (or 4V less than the positive supply). This assures that the  $V_{GS}$  of an "OFF" switch remains greater than its  $V_p$ , and prevents that channel from being falsely turned "ON". When operating with negative input voltages, the gate-to-channel diode will be turned on if the voltage drop across an "ON" switch exceeds  $-0.6V$ . While this condition will cause an error in the output, it will not damage the switch. In lab tests, the multiplexer output has been loaded with a  $0.01\mu F$  capacitor in the circuit of Figure 1. With  $V_1 = -10V$  and  $V_8 = +10V$ , the logic input was driven at a 1kHz rate. The positive-going slew rate was  $0.3V/\mu s$  which is equivalent to a normal  $I_{DSS}$  of 3mA. The negative-going slew rate was  $0.7V/\mu s$  which is equivalent to a "reverse"  $I_{DSS}$  of 7mA. Note that when switch 1 is first turned "ON" it has a drop of  $-20V$  across its terminals. In spite of that fact, the current is limited to approximately twice its normal  $I_{DSS}$ .

CROSSTALK AND OFF-ISOLATION

Crosstalk and off-isolation performance is influenced by the type of package selected. Epoxy (P) packaged devices typically exhibit a 12dB improvement in off-isolation ( $f = 500kHz$ ) performance when compared to ceramic (Q) packaged devices. Epoxy packaged devices typically exhibit a 15dB improvement in crosstalk ( $f = 500kHz$ ) performance when compared to ceramic (Q) packaged devices.

SINGLE SUPPLY OPERATION OF JFET MULTIPLEXERS

PMI's JFET multiplexers will operate from a single positive supply voltage with the negative supply pin at ground potential. The analog signal range will include ground.

For complete single supply operation information, refer to application note, AN-32.

# MUX-08

## SIMPLIFIED MUX-08 SCHEMATIC

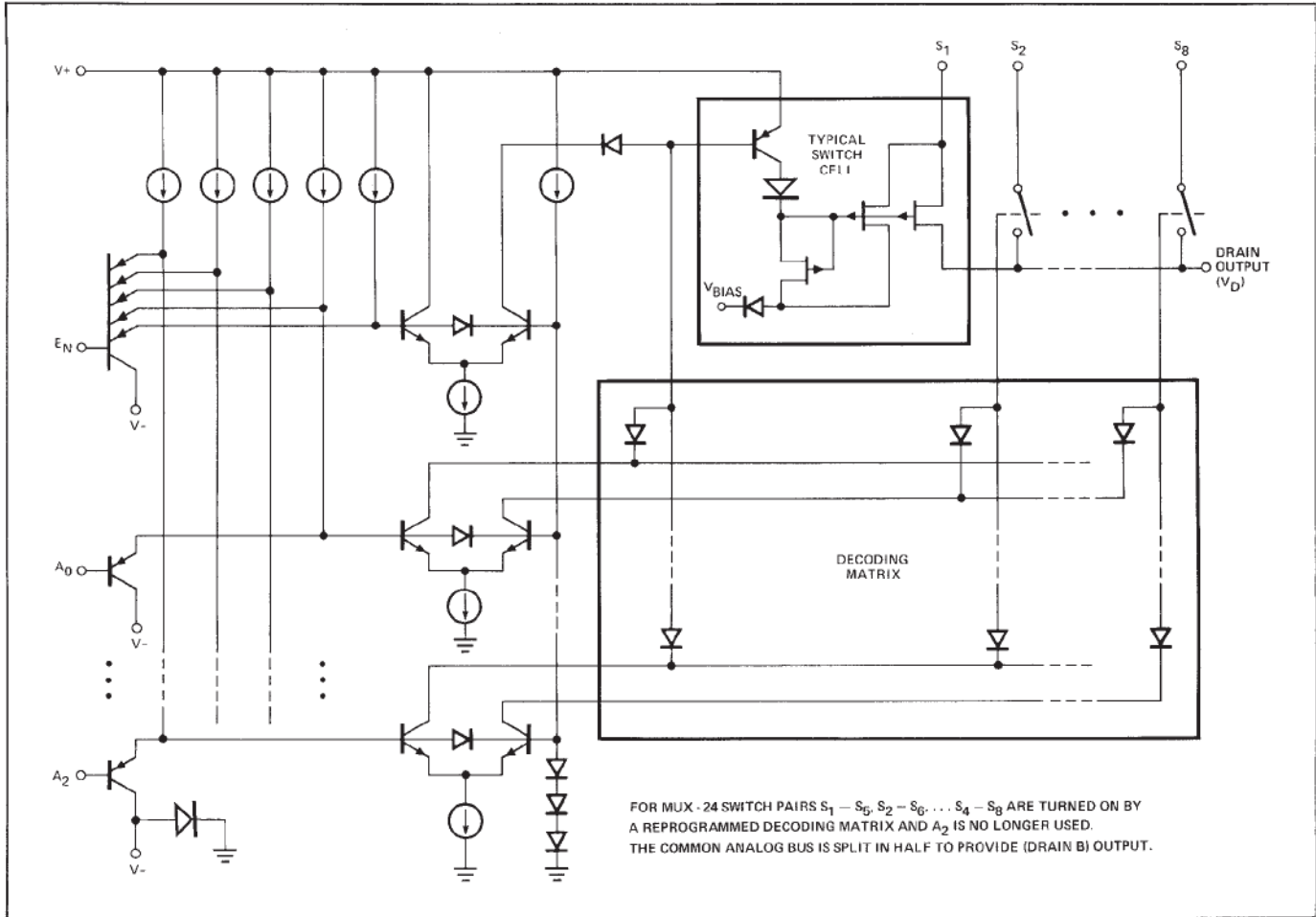

The simplified MUX-08/MUX-24 schematic shows that logic trip points are determined by two forward diode drops. An internal clamping diode between  $V-$  and ground prevents excessive current flow between  $V+$  and ground in the event that  $V-$  becomes open circuit. The decoding matrix is accomplished by a programmed diode array. The switch cell consists of P channel JFET's with appropriate blocking diodes which ruggedizes the circuit's overvoltage and supply loss characteristics.

### DIFFERENTIAL MULTIPLEXERS

One characteristic unique to differential multiplexers (MUX-24) is the ability to reject common-mode signals from becoming differential error signals. Common-mode rejection is a parameter which defines the amount of rejection in terms of dB. The MUX-24 exhibits a 106dB at 60Hz and 101dB at 400Hz of CMRR using the test circuit of Figure 6.

### CMRR TEST CIRCUIT

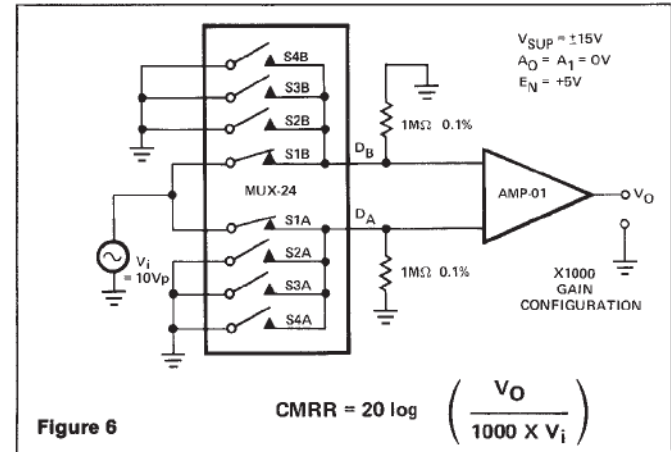

TYPICAL PERFORMANCE CHARACTERISTICS

OVERVOLTAGE V-I CHARACTERISTIC

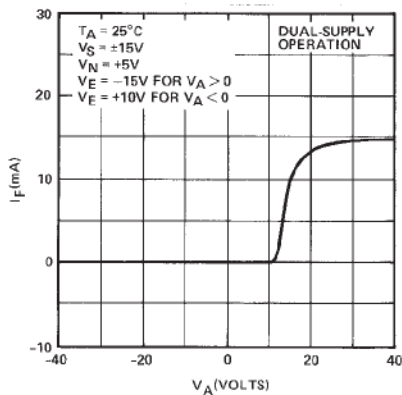

OVERVOLTAGE V-I CHARACTERISTIC

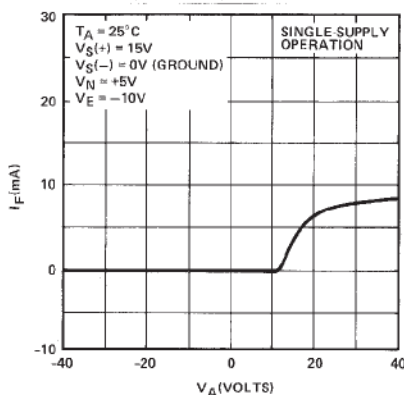

POWER-LOSS V-I CHARACTERISTIC

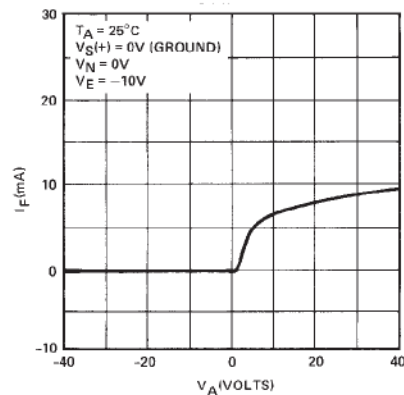

OVERVOLTAGE/POWER-LOSS MEASUREMENT TEST CIRCUIT

