

Structure : Silicon Monolithic Integrated Circuit
 Product Name : Power control for portable CDs

Device Name : **BH6584KV**

- Features :
- Low power consumption
 - Low ON resistance
 - VQFP_48C package
- <Power Control Part>
- Step-up DC/DC converter for microcomputers (With a built-in switching Tr)
 - Main step-up/step-down DC/DC converter (With a built-in switching Tr)
 - Sub step-up DC/DC converter (With a built-in switching Tr)
 - VG step-up circuit for driving power MOS (With a built-in switching Tr)
 - Ripple filter circuit
 - Step-down regulator circuit (2.9V/3.8V, 1.5V)
 - Reset circuit
- <Driver Part>
- Incorporating four channels of power MOS H-bridge drivers
 - Supporting digital input
 - Direct PWM driving method

○ ABSOLUTE MAXIMUM RATINGS (Ta=25°C)

Parameter	Symbol	Limits	Unit
H-bridge Power Supply Voltage	PVCC	7	V
Battery Power Supply Voltage	PVCC0,PVCC1	7	V
Power Supply Voltage for Microcomputer	VMC	7	V
Power Supply Voltage for Core	REGOUT	7	V
System Power Supply Voltage	SVCC	7	V
Sub Power Supply Voltage	VSUB	7	V
AC Adaptor Power Supply Voltage	PVCC2	7	V
Pre Driver Power Supply Voltage	VG	7	V
DSW, USW Output Current	IO	3 ^{*1}	A
Power Dissipation	Pd	1180 ^{*2}	mW
Operating Temperature Range	Topr	-30 to 85	°C
Storage Temperature Range	Tstg	-55 to 150	°C

*1) Maximum time period for applying voltage: 5msec, interrupted current with Duty1/10 or less

*2) When mounted on the PCB board (glass/epoxy board with the size: 70 mm×70 mm, the thickness: 1.6 mm). Over Ta=25°C, derating at the rate of 9.5mW/°C.

○ RECOMMENDED OPERATING CONDITIONS

Parameter	Symbol	MIN	TYP	MAX	Unit
H-bridge Power Supply Voltage	PVCC	1.5	2.4	4.5	V
Battery Power Supply Voltage	PVCC0,PVCC1	1.5	2.4	4.5	V
Power Supply Voltage for Microcomputer	VMC	2.0	2.5	4.5	V
Power Supply Voltage for Core	REGOUT	1.4	1.5	1.6	V
System Power Supply Voltage	SVCC	2.0	2.5	4.5	V
Sub Power Supply Voltage	VSUB	2.0	3.2	4.5	V
AC Adaptor Power Supply Voltage	PVCC2	2.0	4.5	6.5	V
Pre Driver Power Supply Voltage ^{*3}	VG	5.0	6.0	6.9	V
Ambient Temperature	Ta	-10	25	70	°C

*3) When supplied externally without using the built-in step-up circuit.

This product has not been checked for the strategic materials (or service) defined in the Foreign Exchange and Foreign Trade Control Law of Japan so that a verification work is required before exporting it.

Not designed for radiation resistance.

○ ELECTRIC CHARACTERISTICS

(PVCC1=2.4V, SVCC=VMC=2.5V, VSUB=3.2V, VG=6V, Ta=25°C, unless otherwise noted.)

Parameter	Symbol	MIN	TYP	MAX	Unit	Condition
<Whole Circuit>						
PVCC0+PVCC1+PVCC Standby Current	IPVCC01ST	-	100	170	uA	SVCC=VSUB=0V, VMC=3V
VMC Standby Current	IVMCST	-	23	50	uA	SVCC=VSUB=0V, VMC=3V
VG Standby Current	IVGST	-	-	3	uA	SVCC=VSUB=0V, VMC=3V
PVCC0 + PVCC1 Consumption Current	IPVCC01	-	0.7	1.3	mA	
PVCC2 Consumption Current	IPVCC2	-	0.9	1.7	mA	PVCC2=5V
SVCC Consumption Current	ISVCC	-	1.8	2.7	mA	
VSUB Consumption Current	IVSUB	-	0.1	0.2	mA	
LMC Terminal Leak Current	IMCLK	-	-	3	uA	LMC=6V, SVCC=VSUB=0V
VG Consumption Current	IVG	-	0.14	0.3	mA	fCLK=88.2kHz
LG Terminal Leak Current	ILGLK	-	-	3	uA	LG=6V, SVCC=VSUB=0V
<H-bridge Driver>						
Output ON Resistance	RON	-	1.8	2.8	Ω	Sum of ON resistances (top + bottom)
H-level Input Voltage	VIH	1.75	-	-	V	
L-level Input Voltage	VIL	-	-	0.75	V	
Output Propagation Delay Time	tRISE	-	65	300	nsec	
	tFALL	-	40	300	nsec	
Output Propagation Delay Time Difference	ΔtRF	-50	25	200	nsec	tRISE-tFALL
Minimum Input Pulse Width	Tmin	-150	-	-	nsec	Output pulse width 1/2tmin or above
<PVCC2 Monitor Terminal>						
Monitor Terminal Voltage 1	VMON1	1.1	1.2	1.3	V	
Monitor Terminal Voltage 2	VMON2	1.4	1.55	1.7	V	SVCC=1.5V, PVCC1=4.5V
<Step-up/Step-down Converter>						
SVCC Terminal Threshold Voltage	SVCCTH	2.43	2.50	2.57	V	
EO Terminal Output Voltage H	VEOTH	1.1	1.3	-	V	IEO=100 μA
EO Terminal Output Voltage L	VEOL	-	-	0.4	V	IEO=60 μA
VSUB Terminal Threshold Voltage	VSUBTH	3.00	3.20	3.40	V	fCLK=88.2kHz
<Short Protect Part>						
SPRT Terminal Voltage (normal)	VSPRTIN	-	-	0.2	V	
SPRT Terminal Current 1 EO = H	ISPRT1	4	6	9	uA	
SPRT Terminal Current 2 Overcurrent	ISPRT2	8	12	18	uA	PVCC2=6.8V
SPRT Terminal Current 3 Overcurrent At Ground Fault	ISPRT3	1	2.5	4	UA	SVCC=0V
SPRT Terminal Impedance	RSPRT	240	320	400	kΩ	
SPRT Terminal Threshold Voltage	VSPRTH	0.4	0.5	0.6	V	
SPRT Terminal Threshold Voltage At Ground Fault	VSPRTH2	0.2	0.35	0.5	V	SVCC=0V
Overvoltage Protection Detection Voltage	VHVPR	6.2	6.5	6.8	V	
<Soft Start Part>						
SOFT Terminal Output Voltage	VSOFT	1.5	2	2.5	V	
SOFT Terminal Current	ISOFT	7	10	13	uA	
SOFT Terminal Impedance	RSOFT	180	220	280	kΩ	
<Interface Part>						
START Terminal ON Threshold Voltage	VSTATH1	-	-	0.3	V	
START Terminal OFF Threshold Voltage	VSTATH2	1.0	-	-	V	
START Terminal Bias Current	ISTART	51	61	77	uA	START=2.5V
CLK Terminal Threshold Voltage H	VCLKTHH	1.5	-	-	V	fCLK=88.2KHz
CLK Terminal Threshold Voltage L	VCLKYHL	-	-	0.5	V	fCLK=88.2KHz
CLK Terminal Bias Current	VCLK	11	18	25	uA	VCLK=2.5V

Parameter	Symbol	MIN	TYP	MAX	Unit	Condition
<Coil Drive Part>						
DSW Terminal ON Resistance H	RDSWH	-	0.6	1.0	Ω	IDSW=500mA
DSW Terminal ON Resistance L	RDSWL	-	0.6	1.0	Ω	IDSW=500mA
USW Terminal ON Resistance H	RUSWH	-	0.6	1.0	Ω	IUSW=500mA
USW Terminal ON Resistance L	RUSWL	-	0.6	1.0	Ω	
SSW Terminal ON Resistance H	RSSWH	-	2	3.3	Ω	ISSW=100mA
SSW Terminal ON Resistance L	RSSWL	-	2	3.3	Ω	
DSW Terminal Leak Current H	IDSWLKH	-	-	3	μA	START=2.5V, DSW=0V
DSW Terminal Leak Current L	IDSWLKL	-3	-	-	μA	START=2.5V, DSW=2.4V
USW Terminal Leak Current H	IUSWLKH	-	-	3	μA	START=2.5V, USW=0V
USW Terminal Leak Current L	IUSWLKL	-3	-	-	μA	START=2.5V, USW=2.4V
SSW Terminal Leak Current H	ISSWLKH	-	-	3	μA	START=2.5V, SSW=3.2V
SSW Terminal Leak Current L	ISSWLKL	-3	-	-	μA	
<Power Supply for Microcomputer Part>						
LMC Terminal Oscillation Frequency	fLMC	70	105	140	kHz	LMC=2.2V
LMC Terminal Output Voltage L	VLLMC	-	0.1	0.2	V	LMC=2.2V
VMC Terminal Threshold Voltage	VVMCTH	2.12	2.30	2.48	V	LMC=2.3V VMC=2.3→3V
VMC Terminal Threshold Hysteresis Voltage	VVMCHYS	30	60	100	mV	LMC=2.2V VMC=VVMCTH→2V
SVCC-VMC ON Resistance	RVMCSV	-	8	15	Ω	IVMC=50mA
LMCSW Terminal ON Threshold Voltage	VLMSWON	1.5	-	-	V	(Turn OFF the step-up converter oscillation circuit for microcomputer)
LMCSW Terminal OFF Threshold Voltage	VLMSWOFF	-	-	0.5	V	(Turn ON the step-up converter oscillation circuit for microcomputer)
<Starter Circuitry>						
LG Terminal Oscillation Frequency	fLG	75	100	125	kHz	VG=LG=5V
LG Terminal Maximum Pulse Duty	tLGMIN	72	80	88	%	VG=LG=5V
LG Terminal Minimum Pulse Width	DLGMIN	0.1	-	0.5	μsec	LG=1V, VG=5→7V
LG Terminal Output Voltage L	VLGL	-	0.1	0.2	V	VG=LG=5V
VG Terminal Starter Detection Voltage	VVGSTTH	3.1	3.6	4.1	V	VG=3→4.5V
VG Terminal Starter Detection Hysteresis Width	VVGHYS	0.05	0.20	0.35	V	VG=VVGSTTH→3V
VG Terminal Threshold Voltage	VVGTH	5.1	6.0	6.9	V	VLG=5V, VG=5→7V
<Main DC/DC Converter>						
DSW Terminal Oscillation Frequency 1	fDSW1	46	58	70	kHz	EO=0.4V
DSW Terminal Oscillation Frequency 2	fDSW2	-	88.2	-	kHz	EO=0.4V, fCLK=88.2kHz
DSW Terminal Minimum Pulse Width	tDSWMIN	0.01	-	0.5	μsec	EO=0.4V→0.7V fCLK=88.2kHz
USW Terminal Oscillation Frequency 1	fUSW1	46	58	70	kHz	
USW Terminal Oscillation Frequency 2	fUSW2	-	88.2	-	kHz	fCLK=88.2kHz
USW Terminal Maximum Pulse Duty	DUSWMAX	65	73	81	%	fCLK=88.2kHz
USW Terminal Minimum Pulse Width	tUSWMIN	0.01	-	0.5	μsec	EO=0.7→0.4V fCLK=88.2kHz
SSW Terminal Oscillation Frequency 1	fSSW1	46	58	70	kHz	
SSW Terminal Oscillation Frequency 2	fSSW2	-	88.2	-	kHz	fCLK=88.2kHz
USW Terminal Maximum Pulse Duty	DSSWMAX	65	73	81	%	fCLK=88.2kHz
SSW Terminal Minimum Pulse Width	tSSWMIN	0.01	-	2	μsec	
UP/DOWN Switching EO Dead Band Width	VUDEAD	-80	-45	-10	mV	EO=0.4→0.7V sweep fCLK=88.2kHz
USW Terminal Starter Frequency	fUSWSTA	75	100	125	kHz	
USW Terminal Starter Duty	DUSWSTA	16	24	32	%	

Parameter	Symbol	MIN	TYP	MAX	Unit	Condition
<SVCC Circuitry>						
Discharge Reset Voltage	VDIS	1.40	1.51	1.62	V	
Starter→Normal Switching Voltage	VSTN	1.72	1.80	1.88	V	
Normal→Starter Switching Voltage	VNST	1.65	1.73	1.81	V	
Starter→Normal Switching Hysteresis Width	VSTNHIS	40	70	110	mV	VSTN-VNST
<Reset Circuitry>						
RESET1 ON Voltage 1	VRESO11	-	-	0.4	V	SPRT=0.6V
RESET1 ON Voltage 2	VRESO12	1.34	1.42	1.50	V	LMCSW="L"
RESET1 ON Voltage 3	VRESO13	1.71	1.8	1.89	V	LMCSW="H"
RESET1 Reset Voltage	VORESOFT1	1.99	2.1	2.21	V	LMCSW="L", "H"
RESET1 Terminal Output Voltage	VORESET1	-	-	0.4	V	IRESET1=50 μA
RESET1 Terminal Leak Current	LKRESET1	-	-	3	uA	
<Ripple Filter Part>						
AVCC-VSUB Voltage	VRF	170	205	240	mV	IAVCC=5mA
AVCC Terminal ON Resistance	RAVCC	-	3	10	Ω	IAVCC=15mA, VCRP=3.2V
CRP Terminal Input Resistance	RCRP	16	21	25	kΩ	ICRP=5 μA, 10 μA
AVCC Discharge Current	IAVCC	1.7	2.5	4.0	mA	VAVCC=3.1V
<Regulator Circuitry 1>						
Regulator Output Voltage 1	VREG1	3.6	3.8	4.0	V	PVCC1=OPEN, PVCC2=6V, VCNT=2.5V
Regulator Output Voltage 2	VREG2	2.7	2.9	3.1	V	PVCC1=OPEN, PVCC2=6V, VCNT=0.6V
REGB Terminal Output Voltage	VOREGB	-	-	1.7	V	PVCC2=6V, IREG=10mA
REGB Terminal Leak Current	ILKREGB	-	-	3	uA	PVCC1=3.2V, PVCC2=6V, REGB=6V
REGB Terminal Limit Current	ILMREGB	12	17	23	mA	PVCC2=6V
REGB Terminal Current at Ground Fault	IDPREGB	-	100	300	uA	PVCC1=0V, PVCC2=6V, REGB=6V
PNPsat Limit Voltage	VSATLIM	10	30	60	mV	PVCC2=3.5V
PVCC2 Reduced-voltage Mute ON Voltage	VPVCC2LV	-	-	1.3	V	PVCC2 specified
PVCC2 Reduced-voltage Mute OFF Voltage	VPVCC2OF	1.9	-	-	V	PVCC2 specified
VCNT Terminal ON Threshold Voltage	VVCNTTH	1.5	-	-	V	
VCNT Terminal OFF Threshold Voltage	VVCNOTH	-	-	0.5	V	
VCNT Terminal Bias Current H	IVCNTH	15	33	50	uA	VCNT=2.5V
VCNT Terminal Bias Current L	IVCNTL	-	-	3	uA	VCNT=0V
<Regulator Circuitry 2>						
REGOUT Output Voltage	VREGOUT	1.4	1.6	1.6	V	
REGOUT Terminal ON Resistance	RREGOUT	-	-	20	Ω	IREGOUT=50mA

○ OUTLINE DIMENSIONS

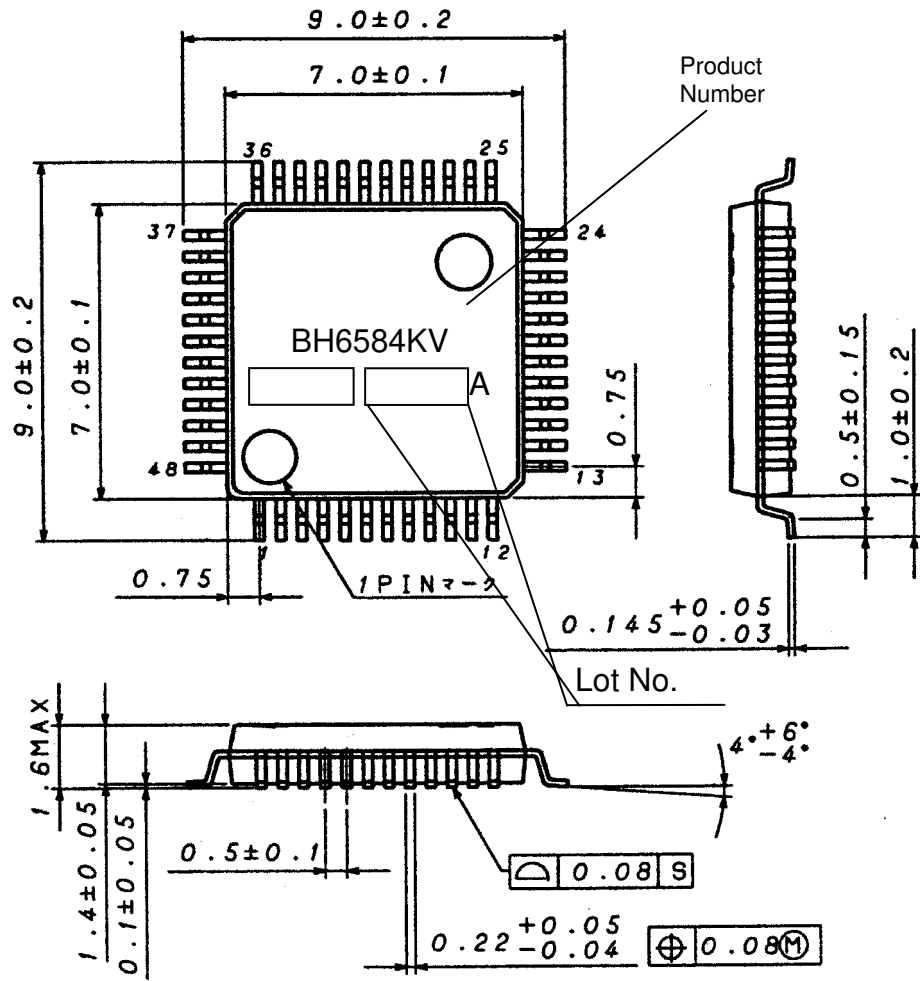

(UNIT: mm)

○ APPLICATION CIRCUIT DIAGRAM

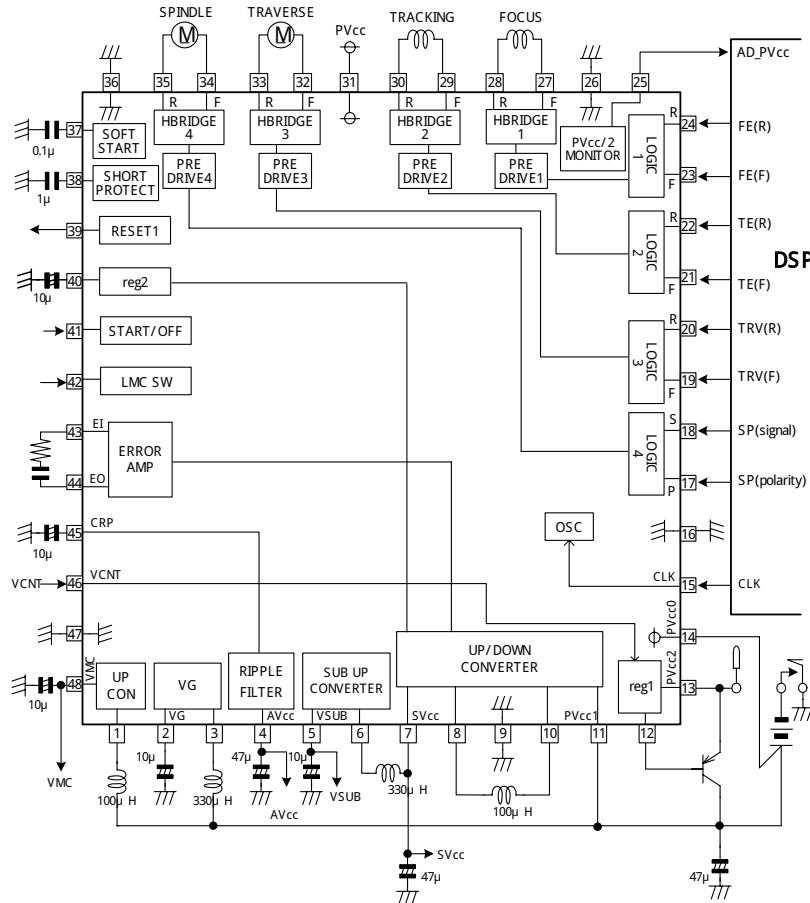

○ PIN Description

No.	Pin name	Description	No.	Pin name	Description
1	LMC	Microcomputer power supply step-up coil driving terminal	25	VMON	PVCC/2 monitor terminal
2	VG	Power MOS driving circuit power supply terminal	26	PGND2	Power part ground 2
3	LG	VG step-up coil driving terminal	27	OUT_1F	CH1 forward output
4	AVCC	Ripple filter output terminal	28	OUT_1R	CH1 reverse output
5	VSUB	Sub power supply terminal	29	OUT_2F	CH2 forward output
6	SSW	Sub step-up coil driving terminal	30	OUT_2R	CH2 reverse output
7	SVCC	Control circuit power supply terminal	31	PVCC	Power part power supply input terminal
8	USW	Main step-up/step-down coil driving terminal 2	32	OUT_3F	CH3 forward output
9	PGND1	Power part ground 1	33	OUT_3R	CH3 reverse output
10	DSW	Main step-up/step-down coil driving terminal 1	34	OUT_4F	CH4 forward output
11	PVCC1	Battery power supply input terminal 1	35	OUT_4R	CH4 reverse output
12	REGB	Tr for regulator 1 driving terminal	36	PGND3	Power part ground 3
13	PVCC2	AC adaptor power supply input terminal	37	SOFT	Soft start setting terminal
14	PVCC0	Battery power supply input terminal 0	38	SPRT	Power OFF time constant setting terminal
15	CLK	DC/DC converter external clock input terminal	39	RESET1	Reset 1 detection output terminal
16	GND	Pre part power supply ground	40	REGOUT	Regulator 2 output terminal
17	IN4P	CH4 input terminal (polarity)	41	START	DC/DC converter ON/OFF terminal
18	IN4S	CH4 input terminal (signal)	42	LMCSW	Step-up converter for microcomputer oscillation circuit ON/OFF terminal
19	IN3F	CH3 forward input terminal	43	EI	Step-up/step-down DC/DC converter error amp input terminal
20	IN3R	CH3 reverse input terminal	44	EO	Step-up/step-down DC/DC converter error amp output terminal
21	IN2F	CH2 forward input terminal	45	CRP	Ripple filter smoothing capacitor connection terminal
22	IN2R	CH2 reverse input terminal	46	VCNT	Regulator voltage switching terminal
23	IN1F	CH1 forward input terminal	47	PGND4	Power part ground 4
24	IN1R	CH1 reverse input terminal	48	VMC	Power supply terminal for microcomputer

Notes

- No technical content pages of this document may be reproduced in any form or transmitted by any means without prior permission of ROHM CO.,LTD.
- The contents described herein are subject to change without notice. The specifications for the product described in this document are for reference only. Upon actual use, therefore, please request that specifications to be separately delivered.
- Application circuit diagrams and circuit constants contained herein are shown as examples of standard use and operation. Please pay careful attention to the peripheral conditions when designing circuits and deciding upon circuit constants in the set.
- Any data, including, but not limited to application circuit diagrams information, described herein are intended only as illustrations of such devices and not as the specifications for such devices. ROHM CO.,LTD. disclaims any warranty that any use of such devices shall be free from infringement of any third party's intellectual property rights or other proprietary rights, and further, assumes no liability of whatsoever nature in the event of any such infringement, or arising from or connected with or related to the use of such devices.
- Upon the sale of any such devices, other than for buyer's right to use such devices itself, resell or otherwise dispose of the same, no express or implied right or license to practice or commercially exploit any intellectual property rights or other proprietary rights owned or controlled by
- ROHM CO., LTD. is granted to any such buyer.
- Products listed in this document are no antiradiation design.

The products listed in this document are designed to be used with ordinary electronic equipment or devices (such as audio visual equipment, office-automation equipment, communications devices, electrical appliances and electronic toys).

Should you intend to use these products with equipment or devices which require an extremely high level of reliability and the malfunction of which would directly endanger human life (such as medical instruments, transportation equipment, aerospace machinery, nuclear-reactor controllers, fuel controllers and other safety devices), please be sure to consult with our sales representative in advance.

It is our top priority to supply products with the utmost quality and reliability. However, there is always a chance of failure due to unexpected factors. Therefore, please take into account the derating characteristics and allow for sufficient safety features, such as extra margin, anti-flammability, and fail-safe measures when designing in order to prevent possible accidents that may result in bodily harm or fire caused by component failure. ROHM cannot be held responsible for any damages arising from the use of the products under conditions out of the range of the specifications or due to non-compliance with the NOTES specified in this catalog.

Thank you for your accessing to ROHM product informations.

More detail product informations and catalogs are available, please contact your nearest sales office.

ROHM Customer Support System

THE AMERICAS / EUROPE / ASIA / JAPAN

www.rohm.com

Contact us : webmaster@rohm.co.jp