

REVISIONS				
P	LT/R	DESCRIPTION	DATE	APP'D
B		REVISED PER ECO-16-005483	13APR2016	AP DG

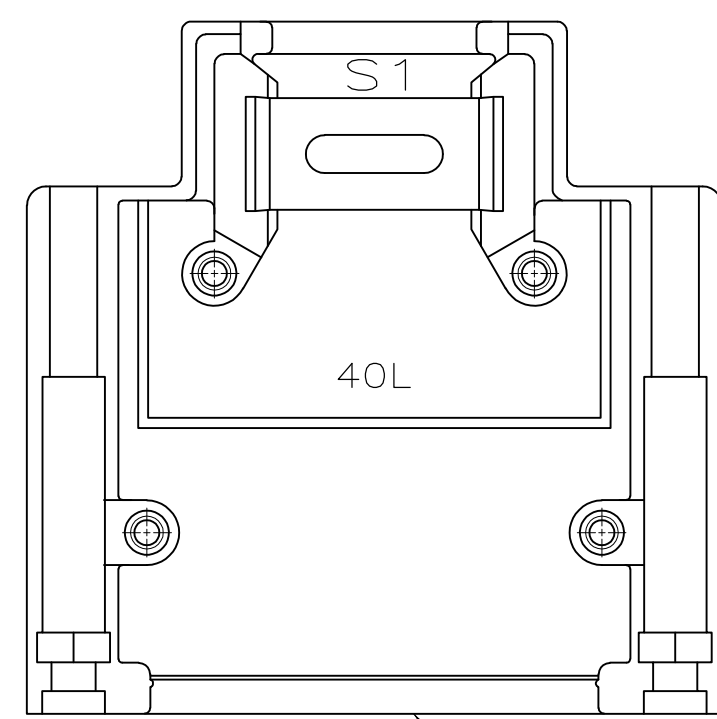
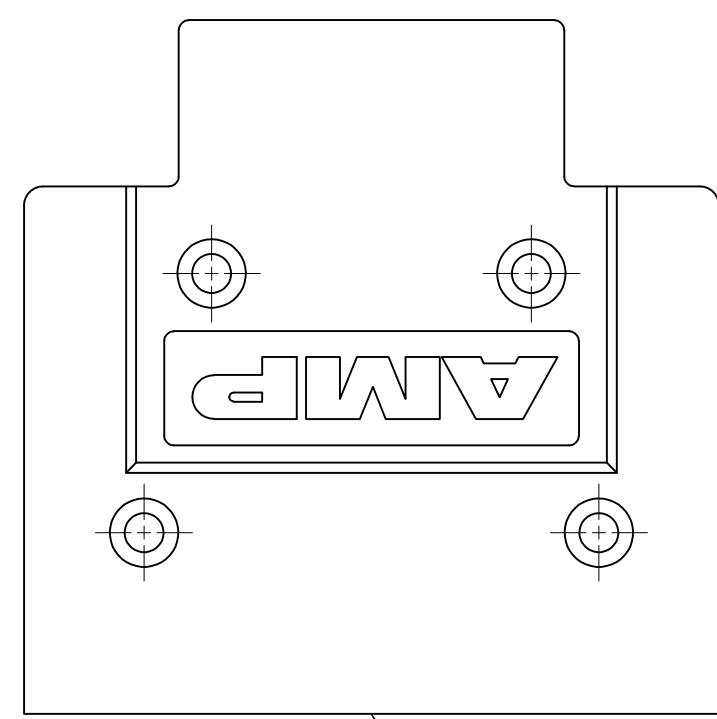
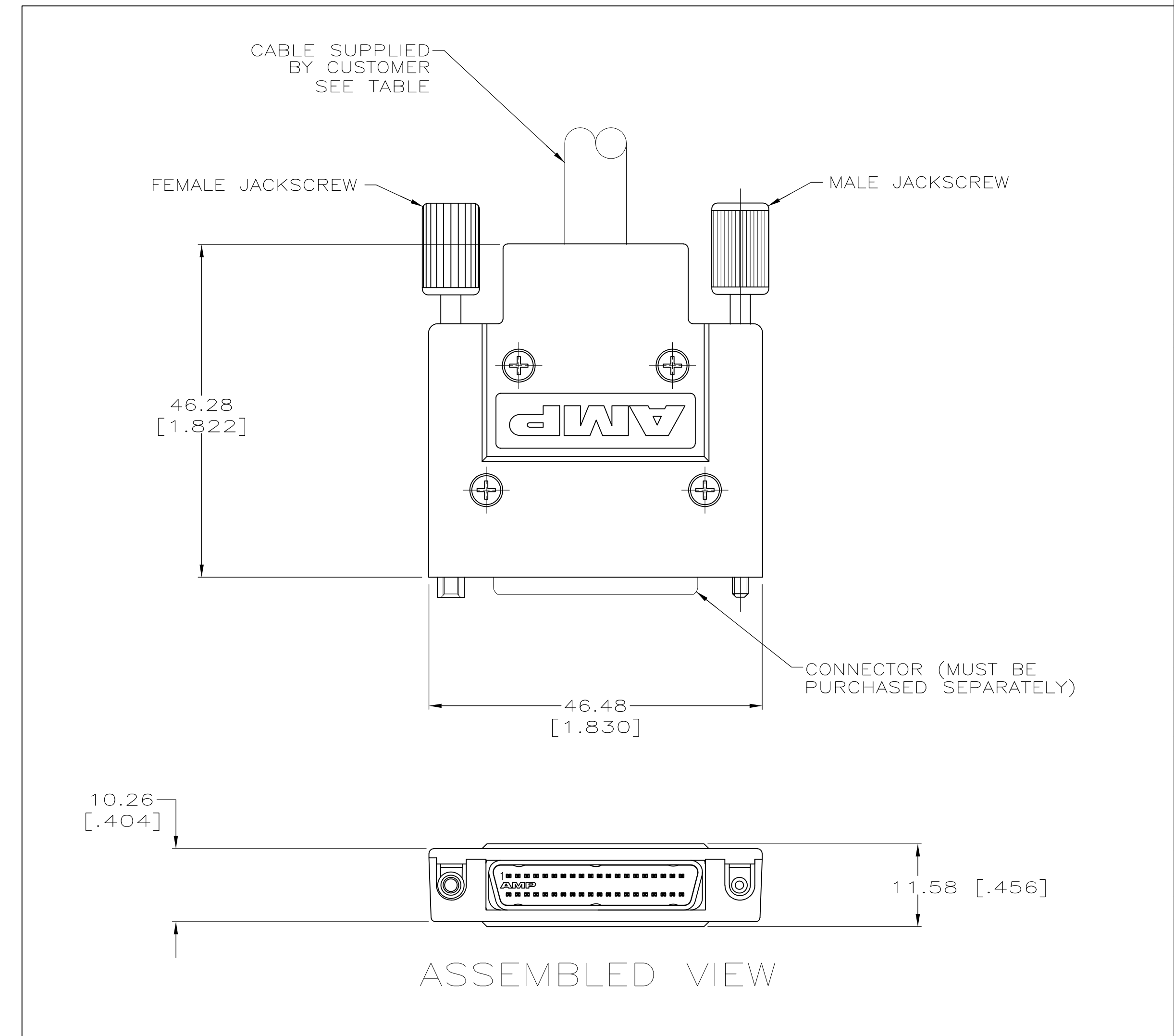
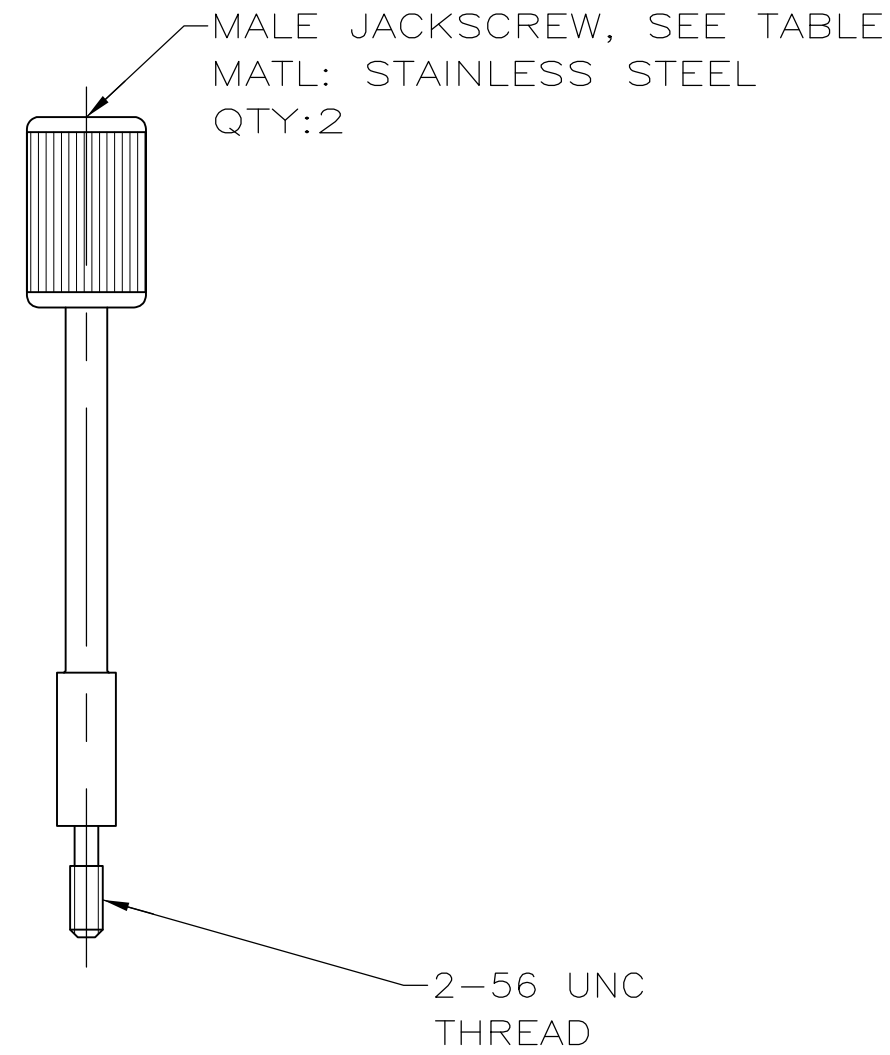
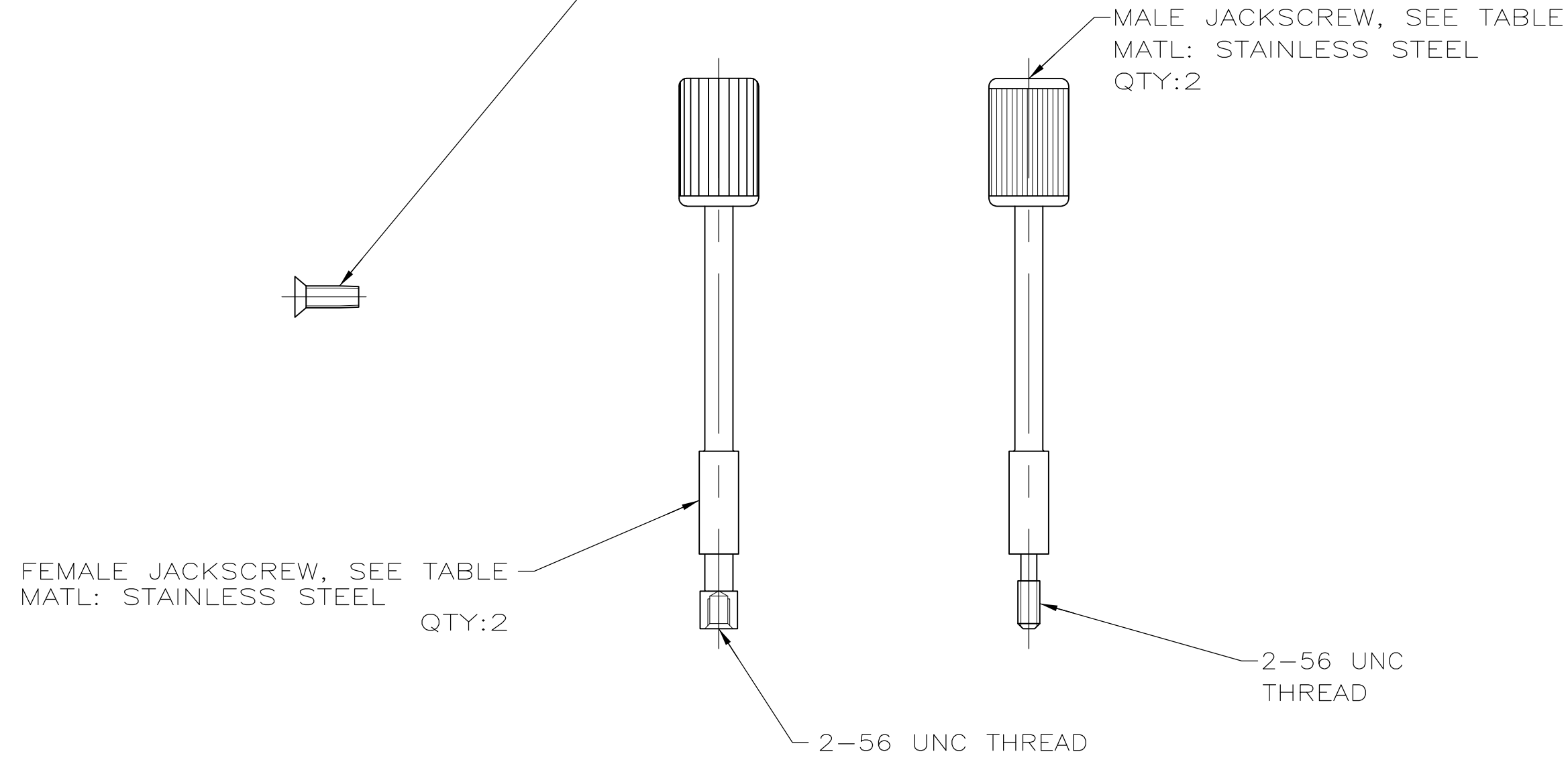
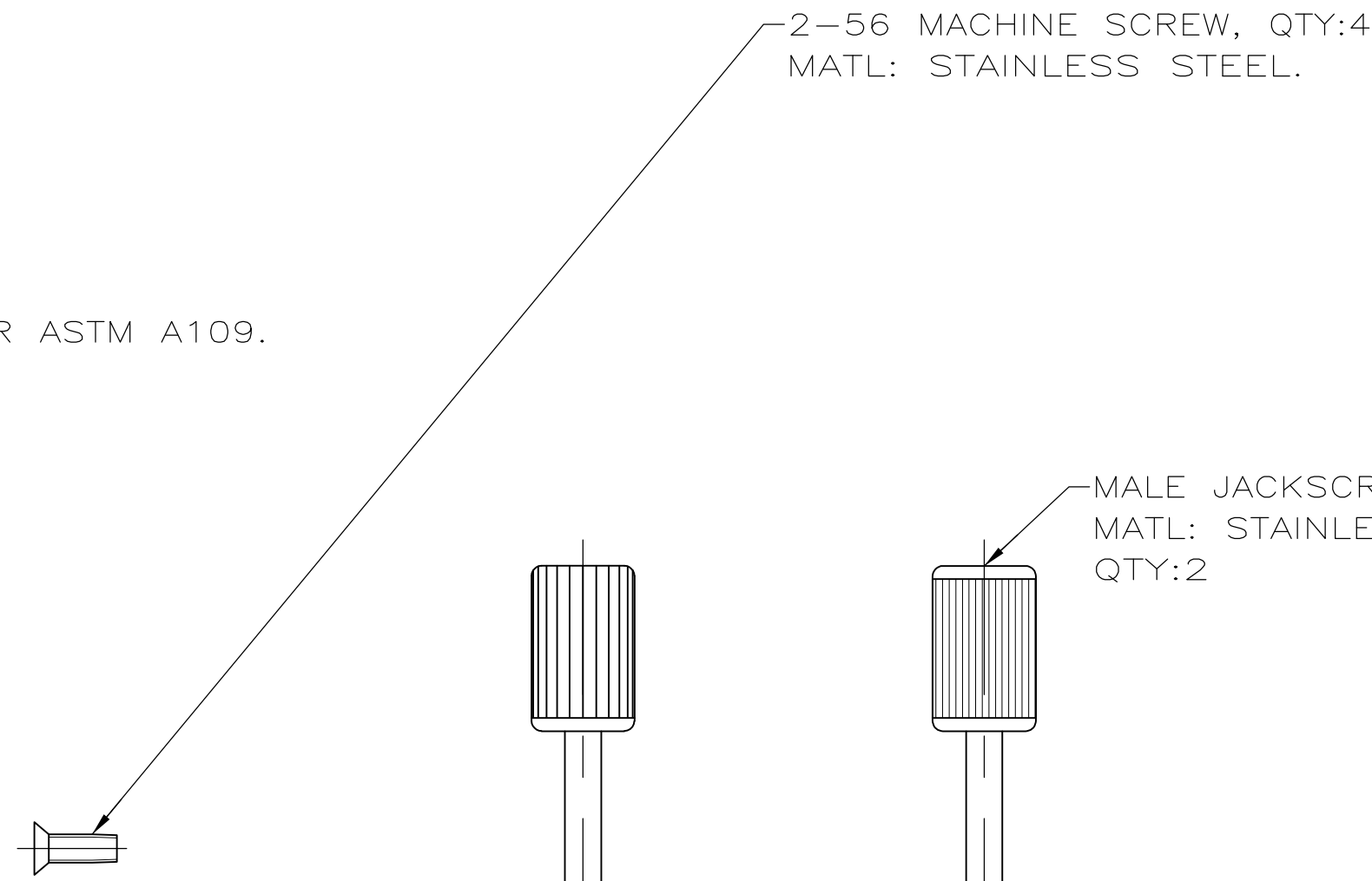
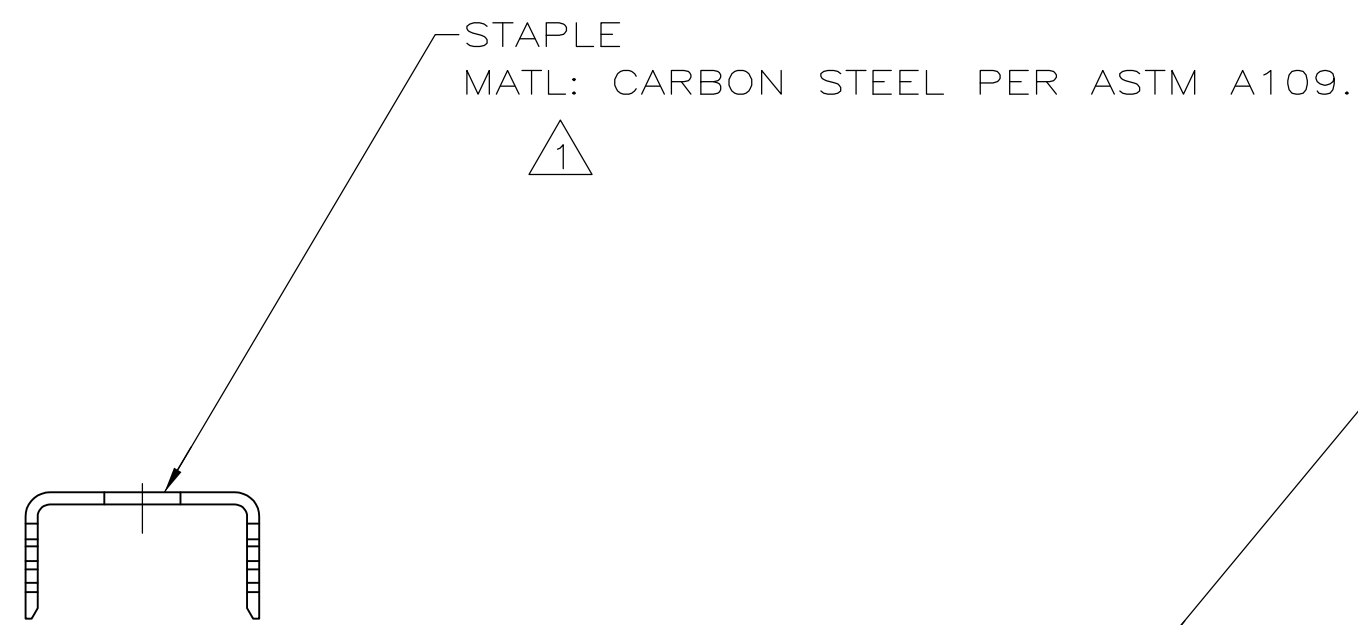

- ① 1.27 μm [.000050] MIN BRIGHT TIN OVER 1.27 μm [.000050] MIN NICKEL.
- ② 2.54 μm [.000100] MIN NICKEL OVER 5.08 μm [.000200] MIN COPPER.
- ③ PARTS INDIVIDUALLY BULK PACKAGED.

JACKSCREW	CABLE MAX DIA.	PART NO.
FEMALE	8.89 [.350]	5787543-9
FEMALE	10.16 [.400]	5787543-8
FEMALE	11.43 [.450]	5787543-7
MALE	8.89 [.350]	5787543-3
MALE	10.16 [.400]	5787543-2
MALE	11.43 [.450]	5787543-1

THIS DRAWING IS A CONTROLLED DOCUMENT.

DIMENSIONS: mm 	TOLERANCES UNLESS OTHERWISE SPECIFIED: 0 PLC ± - 1 PLC ± - 2 PLC ± 0.38[.015] 3 PLC ± - 4 PLC ± - ANGLES ± -	DWN: G.PETERS 26AUG05 CHK: S.SHUEY 26AUG05 APP'D: M.WALMSLEY 26AUG05 PRODUCT SPEC: - APPLICATION SPEC: - WEIGHT: 0.000000 CUSTOMER DRAWING	NAME: BACKSHELL KIT, UNASSEMBLED, 40 POSITION .050 SERIES AMPLIMITE SIZE: A1 CAGE CODE: 00779 DRAWING NO: 5787543 SCALE: 1:1 SHEET: 1 OF 1 REV: B
-----------------------	--	--	---

STE TE Connectivity