

Low Power, High Voltage SPST Analog Switches

DESCRIPTION

The DG447, DG448 are dual supply single-pole/single-throw (SPST) switches. On resistance is 25 Ω maximum and flatness is 2.2 Ω max over the specified analog signal range. These analog switches were designed to provide high speed, low error switching of precision analog signals. The primary application areas are in the routing and switching in telecommunications and test equipment. Combining low power, low leakages, low on-resistance and small physical size, the DG477, DG448 are also ideally suited for portable and battery powered industrial and military equipment.

The DG477 has one normally closed switch, while the DG448 switch is normally open. They operate either from a single +7 V to 36 V supply or from dual ± 4.5 V to ± 20 V supplies. They are offered in the very popular, small TSOP6 package.

FEATURES

- ± 15 V analog signal range
- On-resistance - $R_{DS(on)}$: 25 Ω max.
- Fast switching action - t_{ON} : 100 ns
- V_L logic supply not required
- TTL CMOS input compatible
- Rail to rail signal handling
- Dual or single supply operation
- Compliant to RoHS Directive 2002/95/EC

RoHS
COMPLIANT

BENEFITS

- Wide dynamic range
- Low signal errors and distortion
- Break-before-make switching action
- Simple interfacing
- Reduced board space
- Improved reliability

APPLICATIONS

- Precision test equipment
- Precision instrumentation
- Communications systems
- PBX, PABX systems
- Audio equipment
- Redundant systems
- PC multimedia boards
- Hard disc drives

FUNCTIONAL BLOCK DIAGRAM AND PIN CONFIGURATION

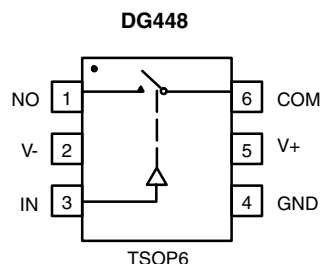
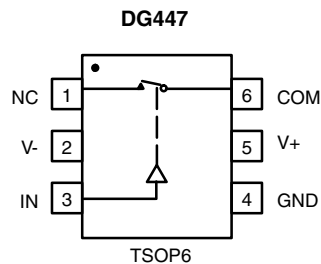

TRUTH TABLE

Logic	DG447	DG448
0	ON	OFF
1	OFF	ON

Logic "0" ≤ 0.8 V
 Logic "1" ≥ 2.4 V

Device Marking:
 DG447DV = G5xxx
 DG448DV = G6xxx



ORDERING INFORMATION

Temp. Range	Package	Part Number
DG447, DG448		
- 40 °C to 85 °C	6-pin TSOP	DG447DV-T1-E3
		DG448DV-T1-E3

ABSOLUTE MAXIMUM RATINGS (T_A = 25 °C, unless otherwise noted)

Parameter Referenced to V-	Limit	Unit	
V+	44	V	
GND	25		
Digital Inputs ^a , V _{no/nc} , V _{COM}	(V-) - 2 V to (V+) + 2 V or 30 mA, whichever occurs first		
Current, (Any Terminal) Continuous	30	mA	
Current (NO or NC or COM) Pulsed at 1 ms, 10 % Duty Cycle	100		
Storage Temperature	- 65 to 150	°C	
Power Dissipation (Package) ^b	6-pin TSOP ^c	570	mW

Notes:

a. Signals on NO, NC, COM, or IN exceeding V+ or V- will be clamped by internal diodes. Limit forward diode current to maximum current ratings.

b. All leads welded or soldered to PC board.

c. Derate 7 mW/°C above 70 °C.

SPECIFICATIONS^a

Parameter	Symbol	Test Conditions Unless Otherwise Specified V+ = 15 V, V- = - 15 V V _{IN} = 2.4 V, 0.8 V ^f	Temp. ^b	D Suffix - 40 °C to 85 °C			Unit
				Min. ^d	Typ. ^c	Max. ^d	
Analog Switch							
Analog Signal Range ^e	V _{ANALOG}		Full	- 15		15	V
Drain-Source On-Resistance	R _{ON}	I _{no/nc} = 10 mA, V _{COM} = 10 V V+ = 13.5 V, V- = - 13.5 V	Room Full		17	25 30	Ω
On-Resistance Flatness	R _{ON} Flatness	I _{no/nc} = 10 mA, V _{COM} = ± 5 V, 0 V V+ = 13.5 V, V- = - 13.5 V	Room Full		0.8	2.2 3	
Switch Off Leakage Current	I _{no/nc(off)}	V+ = 16.5, V- = - 16.5 V V _{COM} = ± 15.5 V V _{no/nc} = -/+ 15.5 V	Room Full	- 1 - 10	- 0.1	1 10	nA
	I _{COM(off)}		Room Full	- 1 - 10	- 0.1	1 10	
Channel On Leakage Current	I _{COM(on)}	V+ = 16.5 V, V- = - 16.5 V V _{COM} = V _{no/nc} = ± 15.5 V	Room Full	- 1 - 10	- 0.1	1 10	
Digital Control							
Input, High Voltage	I _{INH}		Full	2.4			V
Input, Low Voltage	I _{INL}		Full			0.8	
Input Capacitance ^e	C _{IN}		Room		5		pF
Input Current	I _{IN}	V _{IN} = 0 or 5 V		- 1		1	μA
Dynamic Characteristics							
Turn-On Time	t _{ON}	R _L = 300 Ω, C _L = 35 pF V _{no/nc} = ± 10 V	Room Full		100	130 140	ns
Turn-Off Time	t _{OFF}		Room Full		50	95 110	
Charge Injection ^e	Q	C _L = 10 nF, V _{gen} = 0 V, R _{gen} = 0 Ω	Room		10		pC
Off-Isolation ^e	OIRR	C _L = 5 pF, R _L = 50 Ω, f = 1 MHz	Room		- 72		dB
Source Off Capacitance ^e	C _{S(off)}	f = 1 MHz	Room		19		pF
Drain Off Capacitance ^e	C _{D(off)}		Room		8		
Channel On Capacitance ^e	C _{D(on)}		Room		30		
Power Supplies							
Positive Supply Current	I+	V+ = 16.5 V, V- = - 16.5 V V _{IN} = 0 or 5 V	Room Full		16	30 50	μA
Negative Supply Current	I-		Room Full	- 1 - 10	- 0.02		



SPECIFICATIONS ^a							
Parameter	Symbol	Test Conditions Unless Otherwise Specified V ₊ = 12 V, V ₋ = 0 V V _{IN} = 2.4 V, 0.8 V ^f	Temp. ^b	D Suffix - 40 °C to 85 °C			Unit
				Min. ^d	Typ. ^c	Max. ^d	
Analog Switch							
Analog Signal Range ^e	V _{ANALOG}		Full	0		12	V
Drain-Source On-Resistance	R _{ON}	I _{no/nc} = - 10 mA, V _{COM} = 8 V V ₊ = 10.8 V	Room Full		32	45 60	Ω
On-Resistance Flatness	R _{ON} Flatness	I _{no/nc} = 10 mA, V _{COM} = 2, 6, 8 V V ₊ = 10.8 V	Room Full		2	6 8	Ω
Dynamic Characteristics							
Turn-On Time	t _{ON}	V _{NO, NC} = ± 10 V, R _L = 300 Ω, C _L = 35 pF	Room Full		140	175 225	nS
Turn-Off Time	t _{OFF}		Room Full		50	120 150	
Charge Injection ^e	Q	C _L = 10 nF, V _{gen} = 0 V, R _{gen} = 0 Ω	Room		12		pC
Power Supplies							
Positive Supply Current	I ₊	V ₊ = 13.2 V, V _{IN} = 0 V, 5 V	Room Full		22	50 75	μA

Notes:

- a. Refer to PROCESS OPTION FLOWCHART.
- b. Room = 25 °C, full = as determined by the operating temperature suffix.
- c. Typical values are for DESIGN AID ONLY, not guaranteed nor subject to production testing.
- d. The algebraic convention whereby the most negative value is a minimum and the most positive a maximum, is used in this data sheet.
- e. Guaranteed by design, not subject to production test.
- f. V_{IN} = input voltage to perform proper function.

Stresses beyond those listed under "Absolute Maximum Ratings" may cause permanent damage to the device. These are stress ratings only, and functional operation of the device at these or any other conditions beyond those indicated in the operational sections of the specifications is not implied. Exposure to absolute maximum rating conditions for extended periods may affect device reliability.

TYPICAL CHARACTERISTICS (T_A = 25 °C, unless otherwise noted)

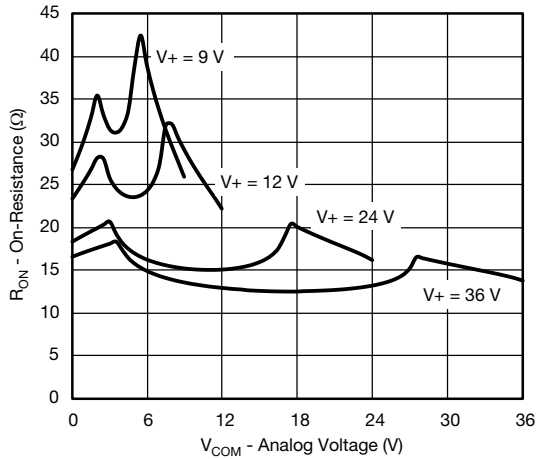

R_{ON} vs. V_{COM} and Single Supply Voltage

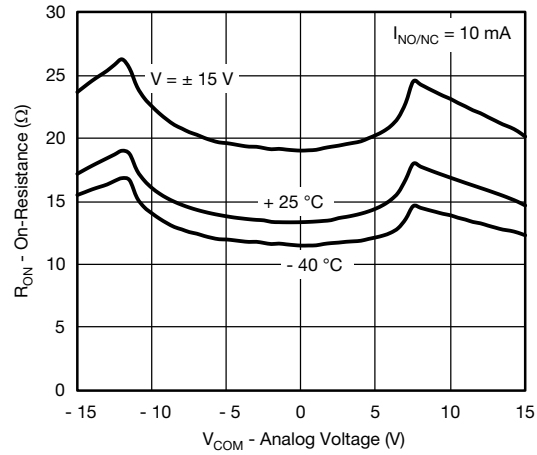

R_{ON} vs. Analog Voltage and Temperature

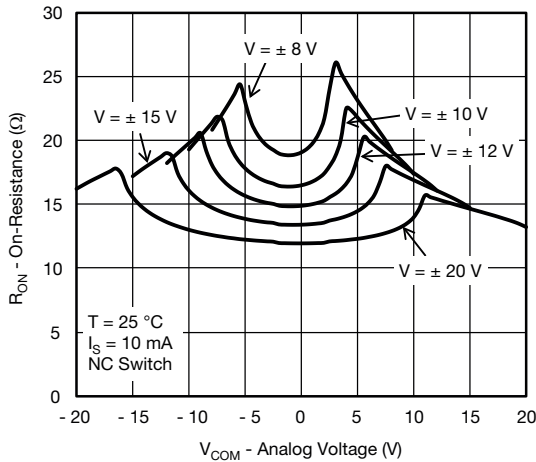

R_{ON} vs. V_{COM} and Dual Supply Voltage

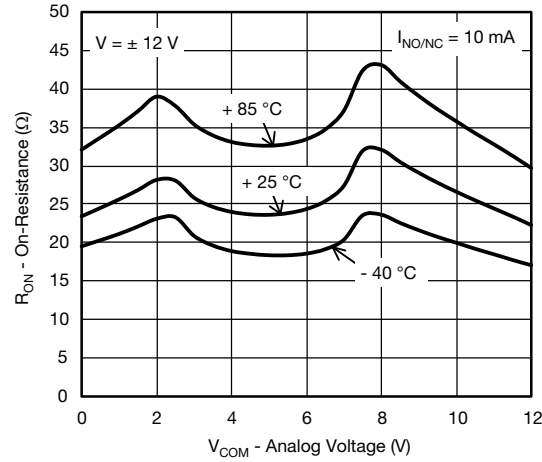

R_{ON} vs. Analog Voltage and Temperature

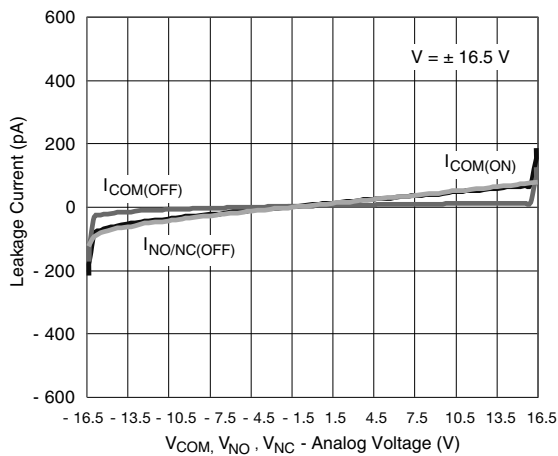

Leakage vs. Analog Voltage

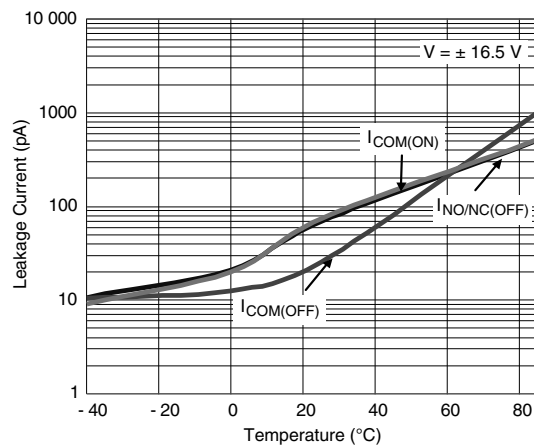

Leakage Current vs. Temperature

TYPICAL CHARACTERISTICS ($T_A = 25^\circ\text{C}$, unless otherwise noted)

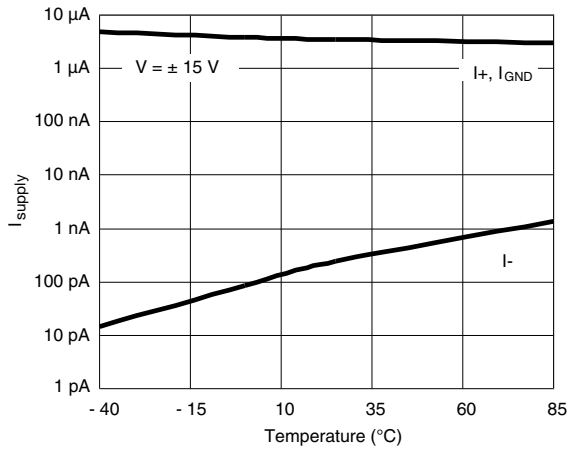

Supply Current vs. Temperature

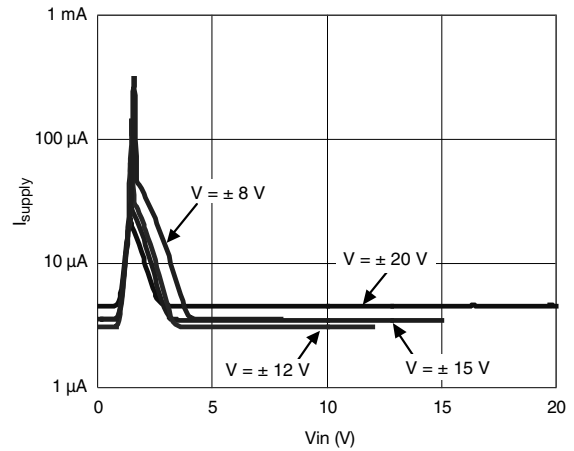

Supply Current vs. V_{IN}

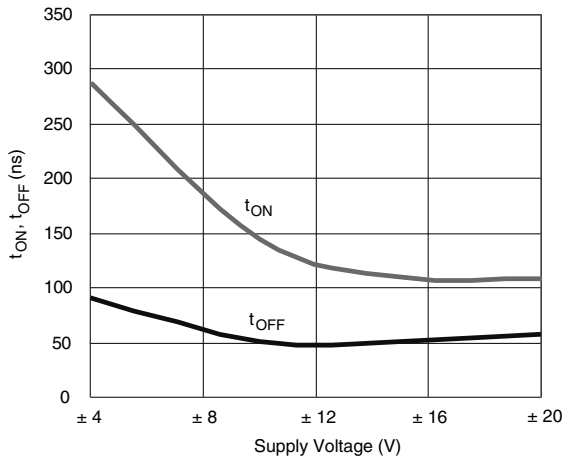

Switching Time vs. Supply Voltages

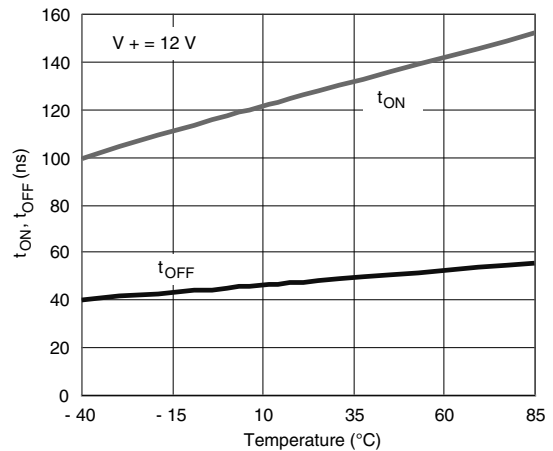

Switching Time vs. Temperature

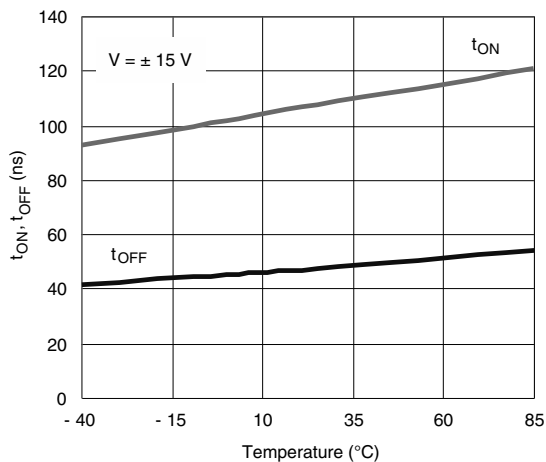

Switching Time vs. Temperature

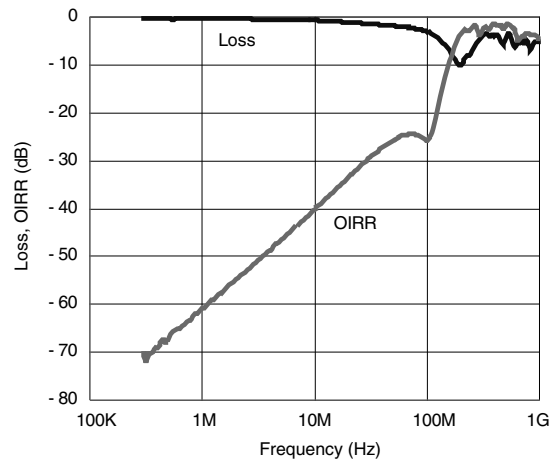

Off Isolation and Insertion Loss vs. Frequency

TYPICAL CHARACTERISTICS ($T_A = 25\text{ }^\circ\text{C}$, unless otherwise noted)

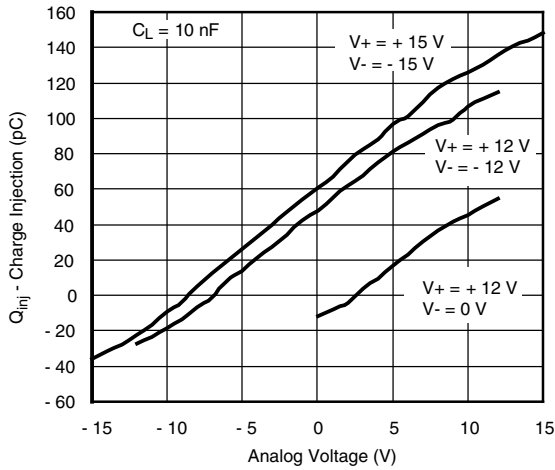

Charge Injection vs. Analog Voltage
(Measured at COM pin)

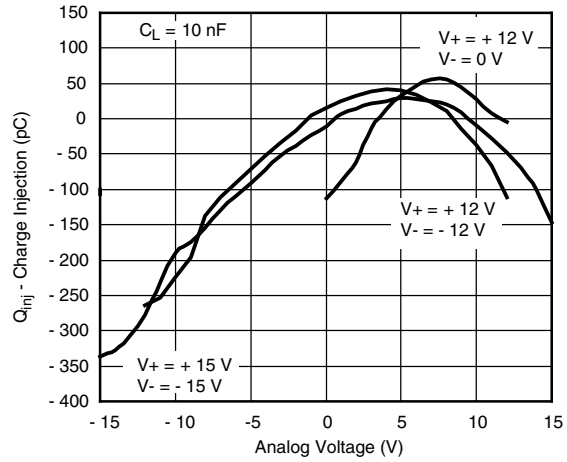

Charge Injection vs. Analog Voltage
(Measured at NC or NO pin)

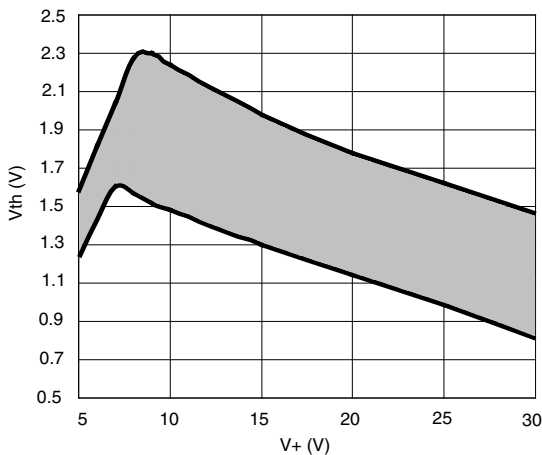

Input Switching Threshold vs. Supply Voltage

TEST CIRCUITS

V_O is the steady state output with the switch on.

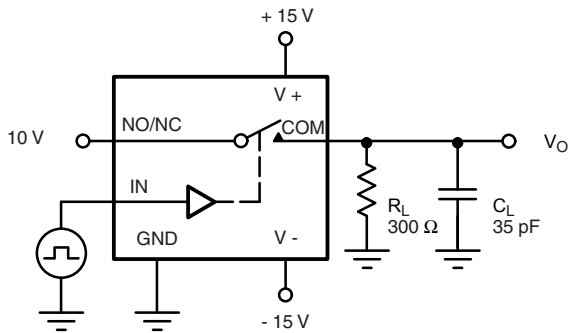

C_L (includes fixture and stray capacitance)

$$V_O = V_S \frac{R_L}{R_L + r_{ON}}$$

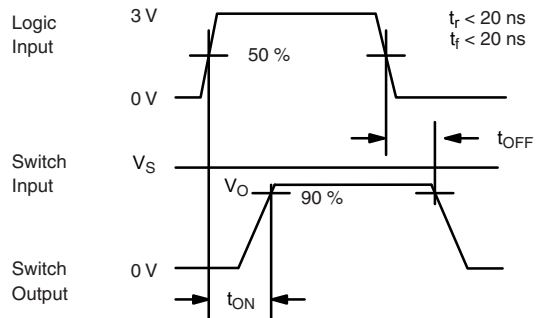

Note: Logic input waveform is inverted for switches that have the opposite logic sense.

Figure 1. Switching Time

TEST CIRCUITS

V_O is the steady state output with the switch on.

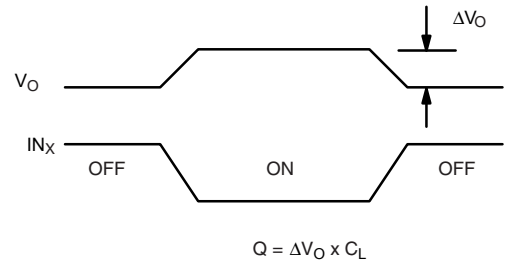
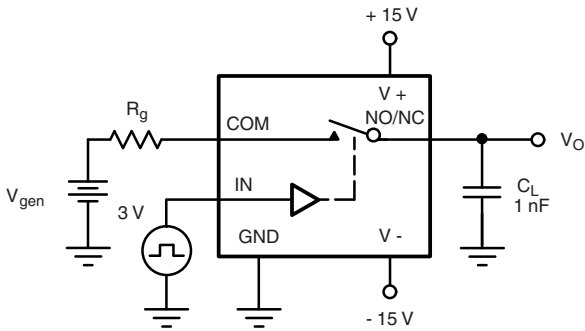
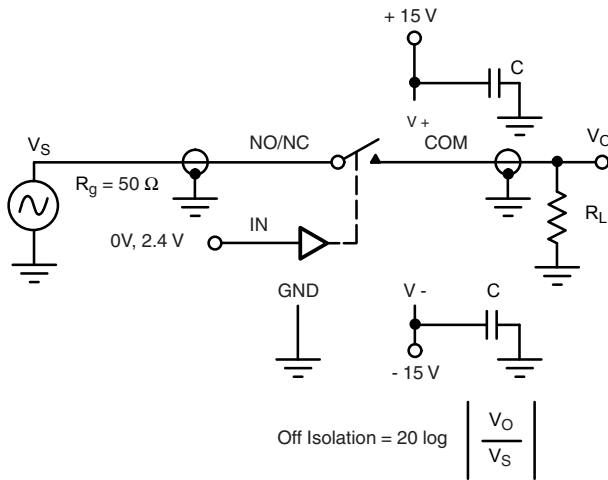

Figure 2. Charge Injection



$$\text{Off Isolation} = 20 \log \left| \frac{V_O}{V_S} \right|$$

Figure 3. Off Isolation

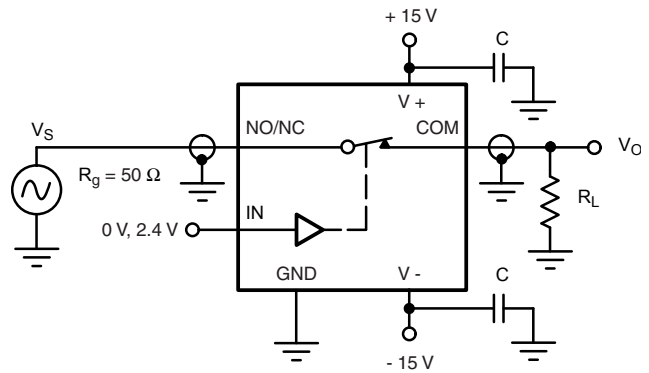

Figure 4. Insertion Loss

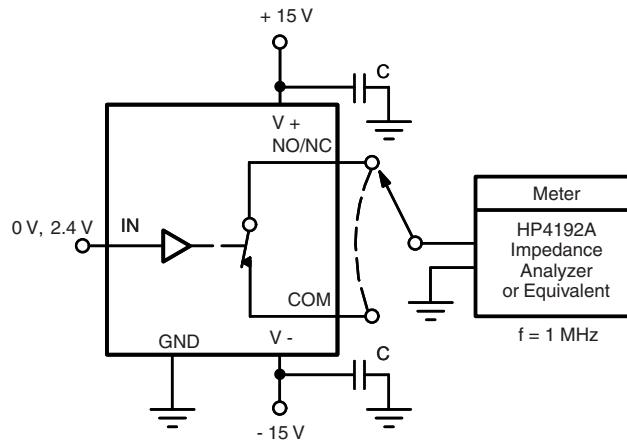
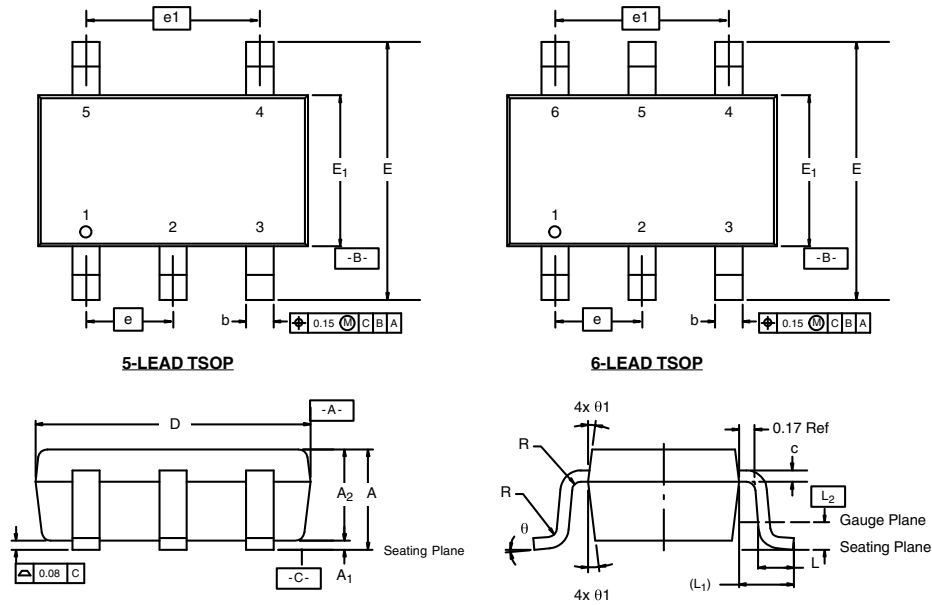

Figure 5. Source/Drain Capacitances

TSOP: 5/6-LEAD
JEDEC Part Number: MO-193C



DIM.	MILLIMETERS			INCHES		
	MIN.	NOM.	MAX.	MIN.	NOM.	MAX.
A	0.91	-	1.10	0.036	-	0.043
A ₁	0.01	-	0.10	0.0004	-	0.004
A ₂	0.90	-	1.00	0.035	0.038	0.039
b	0.30	0.32	0.45	0.012	0.013	0.018
c	0.10	0.15	0.20	0.004	0.006	0.008
D	2.95	3.05	3.10	0.116	0.120	0.122
E	2.70	2.85	2.98	0.106	0.112	0.117
E ₁	1.55	1.65	1.70	0.061	0.065	0.067
e	0.95 BSC			0.0374 BSC		
e ₁	1.80	1.90	2.00	0.071	0.075	0.079
L	0.32	-	0.50	0.012	-	0.020
L ₁	0.60 Ref.			0.024 Ref.		
L ₂	0.25 BSC			0.010 BSC		
R	0.10	-	-	0.004	-	-
θ	0°	4°	8°	0°	4°	8°
θ ₁	7° Nom.			7° Nom.		

Vishay Siliconix maintains worldwide manufacturing capability. Products may be manufactured at one of several qualified locations. Reliability data for Silicon Technology and Package Reliability represent a composite of all qualified locations. For related documents such as package/tape drawings, part marking, and reliability data, see www.vishay.com/ppg?73854.

TSOP: 5/6-LEAD

JEDEC Part Number: MO-193C

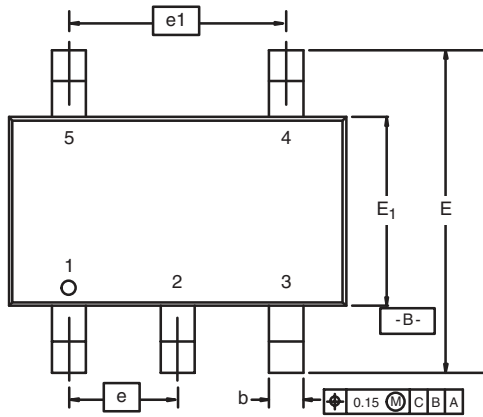

5-LEAD TSOP

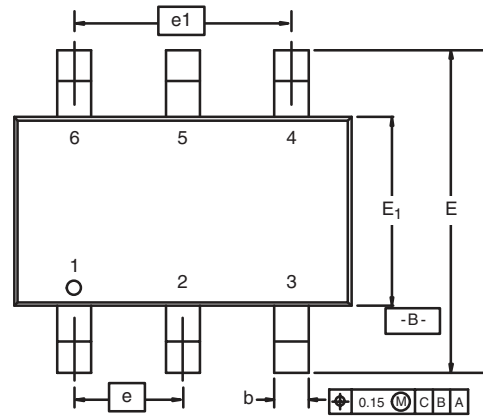

6-LEAD TSOP

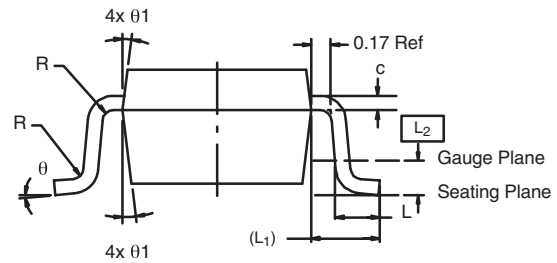
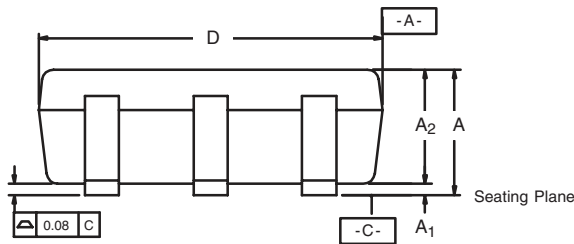

Dim	MILLIMETERS			INCHES		
	Min	Nom	Max	Min	Nom	Max
A	0.91	-	1.10	0.036	-	0.043
A₁	0.01	-	0.10	0.0004	-	0.004
A₂	0.90	-	1.00	0.035	0.038	0.039
b	0.30	0.32	0.45	0.012	0.013	0.018
c	0.10	0.15	0.20	0.004	0.006	0.008
D	2.95	3.05	3.10	0.116	0.120	0.122
E	2.70	2.85	2.98	0.106	0.112	0.117
E₁	1.55	1.65	1.70	0.061	0.065	0.067
e	0.95 BSC			0.0374 BSC		
e₁	1.80	1.90	2.00	0.071	0.075	0.079
L	0.32	-	0.50	0.012	-	0.020
L₁	0.60 Ref			0.024 Ref		
L₂	0.25 BSC			0.010 BSC		
R	0.10	-	-	0.004	-	-
θ	0°	4°	8°	0°	4°	8°
θ₁	7° Nom			7° Nom		
ECN: C-06593-Rev. I, 18-Dec-06						
DWG: 5540						



Disclaimer

ALL PRODUCT, PRODUCT SPECIFICATIONS AND DATA ARE SUBJECT TO CHANGE WITHOUT NOTICE TO IMPROVE RELIABILITY, FUNCTION OR DESIGN OR OTHERWISE.

Vishay Intertechnology, Inc., its affiliates, agents, and employees, and all persons acting on its or their behalf (collectively, "Vishay"), disclaim any and all liability for any errors, inaccuracies or incompleteness contained in any datasheet or in any other disclosure relating to any product.

Vishay makes no warranty, representation or guarantee regarding the suitability of the products for any particular purpose or the continuing production of any product. To the maximum extent permitted by applicable law, Vishay disclaims (i) any and all liability arising out of the application or use of any product, (ii) any and all liability, including without limitation special, consequential or incidental damages, and (iii) any and all implied warranties, including warranties of fitness for particular purpose, non-infringement and merchantability.

Statements regarding the suitability of products for certain types of applications are based on Vishay's knowledge of typical requirements that are often placed on Vishay products in generic applications. Such statements are not binding statements about the suitability of products for a particular application. It is the customer's responsibility to validate that a particular product with the properties described in the product specification is suitable for use in a particular application. Parameters provided in datasheets and / or specifications may vary in different applications and performance may vary over time. All operating parameters, including typical parameters, must be validated for each customer application by the customer's technical experts. Product specifications do not expand or otherwise modify Vishay's terms and conditions of purchase, including but not limited to the warranty expressed therein.

Hyperlinks included in this datasheet may direct users to third-party websites. These links are provided as a convenience and for informational purposes only. Inclusion of these hyperlinks does not constitute an endorsement or an approval by Vishay of any of the products, services or opinions of the corporation, organization or individual associated with the third-party website. Vishay disclaims any and all liability and bears no responsibility for the accuracy, legality or content of the third-party website or for that of subsequent links.

Except as expressly indicated in writing, Vishay products are not designed for use in medical, life-saving, or life-sustaining applications or for any other application in which the failure of the Vishay product could result in personal injury or death. Customers using or selling Vishay products not expressly indicated for use in such applications do so at their own risk. Please contact authorized Vishay personnel to obtain written terms and conditions regarding products designed for such applications.

No license, express or implied, by estoppel or otherwise, to any intellectual property rights is granted by this document or by any conduct of Vishay. Product names and markings noted herein may be trademarks of their respective owners.