

Data Sheet

Customer:

Product: Ultra Low Ohm (Metal Strip) Chip Resistor -LR Series

Size: 1206/2010/2512

Issued Date: 15-Feb-22

Edition: REV.D2



VIKING TECH CORPORATION

光頡科技股份有限公司

No.70 Guangfu N. Rd., Hukou
Township, Hsinchu County 303,
Taiwan

TEL:886-3-5972931

FAX:886-3-5972935•886-3-5973494

E-mail:sales@viking.com.tw

VIKING TECH CORPORATION KAOHSIUNG BRANCH

光頡科技股份有限公司高雄分公司

No.248-3, Sin-Sheng Rd., Cian-Jhen Dist., Kaohsiung,
806, Taiwan

TEL:886-7-8217999

FAX:886-7-8228229

E-mail:sales@viking.com.tw

VIKING ELECTRONICS (WUXI) CO., LTD.

光頡電子(無錫)有限公司

No.22 Xixia Road, Machinery & Industry Park,
National Hi-Tech Industrial Development Zone
of Wuxi, Wuxi, Jiangsu Province, China
Zip Code:214028

TEL:86-510-85203339

FAX:86-510-85203667•86-510-85203977

E-mail:china@viking.com.tw

Produced by (QC)	Checked (QC)	Approved by (QC)	Prepared by (Sales)	Accepted by (Customer)
15-Feb-22	15-Feb-22	15-Feb-22		
Susan Huang	J.C.Liu	J.C.Liu		

Ultra Low Ohm (Metal Strip) Chip Resistor



■ Features

- High power rating up to 3 Watts
- Low TCR down to ± 50 PPM/ $^{\circ}$ C
- Resistance values from 0.5m to 10m ohm
- Customized resistance available
- Wide range package sizes 1206 / 2010 / 2512
- AEC-Q200 Compliance (only LR12 Black)

■ Applications

- NB (for Power Management)
- MB (for Power Management)
- SWPS (DC-DC Converter, Charger, Adaptor)
- Monitor (for Power Management)

■ Construction & Dimension

2512

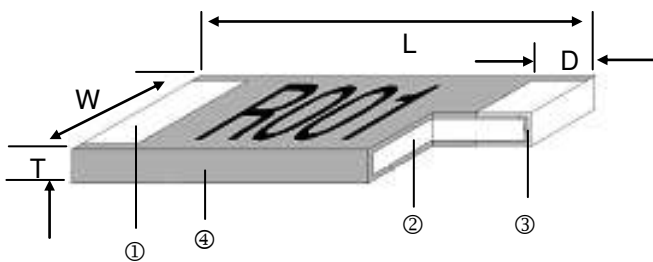

Black – Wave or Reflow soldering

① Solder Plating	③ Barrier Layer
② Alloy Plate	④ Overcoat

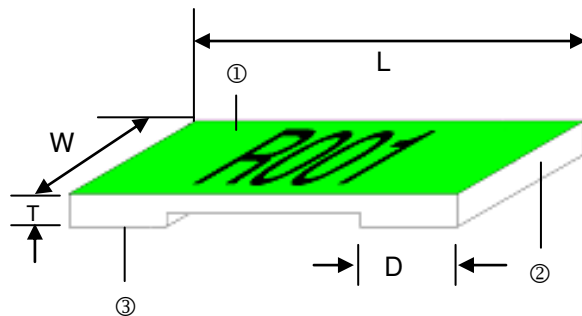

Green – Reflow soldering only

① Overcoat	③ Solder Plating
② Alloy Plate	

1206 & 2010

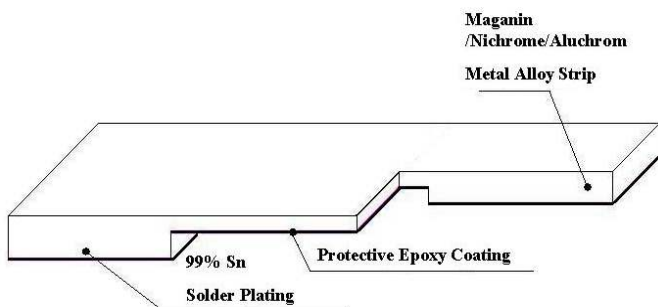

Type	Resistance	Material
1206	0M50~R003	Manganese, Copper
	3M50~R010	Aluminum, Iron, Chromium
2010	0M50~3M50	Manganese, Copper
	R004~R010	Aluminum, Iron, Chromium

■ Dimensions

Unit: mm

Part No.	Resistance (mΩ)	L	W	T	D	Weight (g) (1000pcs)
LR06□TF0M50	0.5	3.20±0.25	1.60±0.10	0.60±0.20	1.35±0.25	22.6
LR06□TD0M75	0.75	3.20±0.25	1.60±0.10	0.60±0.20	1.23±0.25	22.6
LR06□T□□□□□	1.0 , 3.5, 4.0 , 5.0 , 6.0	3.20±0.25	1.60±0.10	0.60±0.20	1.10±0.25	22.6
LR06□T□□□□□	2.0 , 2.5, 3.0 , 10	3.20±0.25	1.60±0.10	0.60±0.20	0.60±0.25	22.6
LR06□T□□□□□	1.2 , 1.5 , 7.0 , 8.0 , 9.0	3.20±0.25	1.60±0.10	0.60±0.20	0.90±0.25	22.6
LR10□TEA0M50	0.5	5.08±0.25	2.54±0.15	0.60±0.20	2.17±0.25	42.3
LR10□TDA0M75	0.75	5.08±0.25	2.54±0.15	0.60±0.20	2.04±0.25	42.3
LR10□TDA□□□□	1.0 , 1.5	5.08±0.25	2.54±0.15	0.60±0.20	1.84±0.25	42.3
LR10□TDA□□□□	2.0, 6.0 , 7.0 , 8.0	5.08±0.25	2.54±0.15	0.60±0.20	1.54±0.25	42.3
LR10□TDA□□□□	3.0 , 3.5	5.08±0.25	2.54±0.15	0.60±0.20	1.04±0.25	42.3
LR10□TDA□□□□	4.0 , 5.0, 5.5	5.08±0.25	2.54±0.15	0.60±0.20	1.84±0.25	42.3
LR10□TDA□□□□	9.0 , 10	5.08±0.25	2.54±0.15	0.60±0.20	1.29±0.25	42.3
LR12□T□□0M50G	0.50	6.35±0.25	3.00±0.20	0.60±0.20	2.68±0.25	59.13
LR12□T□□0M75G	0.75	6.35±0.25	3.00±0.20	0.60±0.20	2.48±0.25	59.13
LR12□T□□□□□□G	1.0 , 5.0 , 6.0	6.35±0.25	3.00±0.20	0.60±0.20	1.93±0.25	59.13
LR12□T□□□□□□G	1.5 , 6.5 , 7.0, 7.5	6.35±0.25	3.00±0.20	0.60±0.20	1.43±0.25	59.13
LR12□T□□□□□□G	2.0 , 2.5 , 3.0 , 3.5	6.35±0.25	3.00±0.20	0.60±0.20	1.18±0.25	59.13
LR12□T□□□□□□G	4.0 , 4.5	6.35±0.25	3.00±0.20	0.60±0.20	2.18±0.25	59.13
LR12□T□□□□□□G	5.0 , 6.0	6.35±0.25	3.00±0.20	0.60±0.20	1.93±0.25	59.13
LR12□T□□□□□□G	8.0 - 10	6.35±0.25	3.00±0.20	0.60±0.20	1.18±0.25	59.13
LR12□T□□0M50	0.50	6.35±0.254	3.18±0.254	1.25±0.20	1.30±0.38	184.11
LR12□T□□0M75	0.75	6.35±0.254	3.18±0.254	0.75±0.20	1.30±0.38	131.11
LR12□T□□R001	1.00	6.35±0.254	3.18±0.254	0.65±0.20	1.30±0.38	110.85
LR12□T□□1M50	1.50	6.35±0.254	3.18±0.254	0.45±0.20	1.30±0.38	67.16
LR12□T□□R002	2.00	6.35±0.254	3.18±0.254	0.35±0.20	1.30±0.38	49.30
LR12□T□□2M50	2.50	6.35±0.254	3.18±0.254	0.65±0.20	1.30±0.38	97.95
LR12□T□□R003	3.00	6.35±0.254	3.18±0.254	0.55±0.20	1.30±0.38	83.49
LR12□T□□R004	4.00	6.35±0.254	3.18±0.254	0.45±0.20	1.30±0.38	62.59
LR12□T□□R005	5.00	6.35±0.254	3.18±0.254	0.35±0.20	1.30±0.38	49.84
LR12□T□□R006	6.00	6.35±0.254	3.18±0.254	0.32±0.20	1.30±0.38	41.76
LR12□T□□6M50	6.50	6.35±0.254	3.18±0.254	0.30±0.20	1.30±0.38	35.85
LR12□T□□R007	7.00	6.35±0.254	3.18±0.254	0.27±0.20	1.30±0.38	34.01
LR12□T□□R010	10.00	6.35±0.254	3.18±0.254	0.25±0.20	1.30±0.38	25.97

■ Part Numbering

LR	12	J	T	E	S	R002	G
Product Type	Dimensions (L×W) 06: 1206 10: 2010 12: 2512	Resistance Tolerance F: ±1% H: ±3% J: ±5%	Packaging Code T: Taping Reel	TCR (PPM/°C) D: ±50 E: ±100 W: ±75 F: ±200 K: ±150	Power Rating : Standard A: 1.5W B: 2.5W R: 3W S: 2W	Resistance R002: 0.002Ω R010: 0.01Ω 0M50: 0.0005Ω 1M50: 0.0015Ω	Marking : Black Coating G: Green Coating **2010/1206 No coating / marking

Standard Electrical Specifications

Item Part No.	Power Rating at 70°C	Operating Temp. Range	Resistance Range (mΩ)			TCR (PPM/°C)
			±1%	±3%	±5%	
LR06□TF0M50	1W	-55°C ~ +170°C	0.5			±200
LR06□TD□□□□	1W		0.75 - 10			±50
LR12□TD□□□□	1W		0.5, 0.75, 1, 1.5, 2			±50
LR12□TW□□□□	1W		6, 6.5, 7			±75
LR12□TE□□□□	1W		4, 5, 10			±100
LR12□TK□□□□	1W		2.5, 3			±150

High Power Rating Electrical Specifications

Item Part No.	Power Rating at 70°C	Operating Temp. Range	Resistance Range (mΩ)			TCR (PPM/°C)
			±1%	±3%	±5%	
LR10□TEA0M50	1.5W	-55°C ~ +170°C	0.5			±100
LR10□TDA□□□□	1.5W		0.75 - 10			±50
LR12□TDS□□□□	2W		0.5, 0.75, 1, 1.5, 2			±50
LR12□TWS□□□□	2W		6, 6.5, 7			±75
LR12□TES□□□□	2W		4, 5, 10			±100
LR12□TKS□□□□	2W		2.5, 3			±150
LR12□TDR□□□□	3W		0.5, 0.75, 1, 1.5, 2			±50
LR12□TWR□□□□	3W		6, 6.5, 7			±75
LR12□TER□□□□	3W		4, 5, 10			±100
LR12□TKR□□□□	3W		2.5, 3			±150
LR12□TDS□□□□G	2W		6.5, 7, 8, 9, 10			±50
LR12□TDB□□□□G	2.5W		4, 4.5, 5, 6			±50
LR12□TDR□□□□G	3W		1, 1.5, 2, 2.5, 3, 3.5			±50
LR12□TER□□□□G	3W		0.5, 0.75			±100

Operating Current = $\sqrt{P/R}$, Operating Voltage = $\sqrt{P \cdot R}$

■ Viking has the ability of manufacture following options based on customer's requirement.

Resistance codes example

For Green Coating

Resistance	0.5mΩ	1.5mΩ	1mΩ	2mΩ	7mΩ	10mΩ
Marking	M50	1M5	R001	R002	R007	R010

For Black Coating

Resistance	0.5mΩ	1.5mΩ	1mΩ	2mΩ	7mΩ	10mΩ
Marking	0M50	1M50	R001	R002	R007	R010

■Reflow

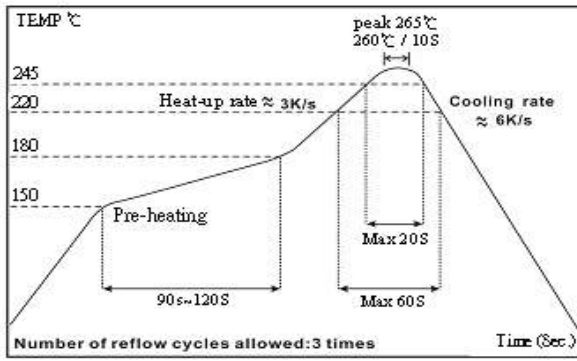

- Green coating "Reflow Air Convection" is available
- Green coating can't be working with wave soldering bath

■Environmental Characteristics

Item	Requirement		Test Method
	Black coating	Green coating	
Temperature Coefficient of Resistance (T.C.R.)	As Spec.		MIL-STD-202 Method 304 +25°C ~125°C, 25°C is the reference temperature
Short Time Overload	±0.5%	±1%	JIS-C-5201-1 5.5 5*rated power for 5 seconds
Endurance	±1%	±1%	MIL-STD-202 Method 108A 70±2°C, RCWV for 1000 hrs with 1.5 hrs "ON" and 0.5 hr "OFF"
Dry Heat	±1%	±1%	JIS-C-5201-1 7.2 at +170°C for 1000 hrs
Solderability	95% min. coverage		MIL-STD-202 Method 208H 245±5°C for 3 seconds
Resistance to Soldering Heat	±0.5%	±1%	MIL-STD-202 Method 210E 260±5°C for 10 seconds
Thermal Shock	±0.5%	±1%	MIL-STD-202 Method 107G -55°C ~ 150°C, 100 cycles

**Green coating can't be work with wave soldering bath.

RCWV(Rated Continuous Working Voltage)= $\sqrt{P \cdot R}$ or Max. Operating Voltage whichever is lower

■Storage Temperature: 15~28°C; Humidity < 80%RH

■Derating Curve

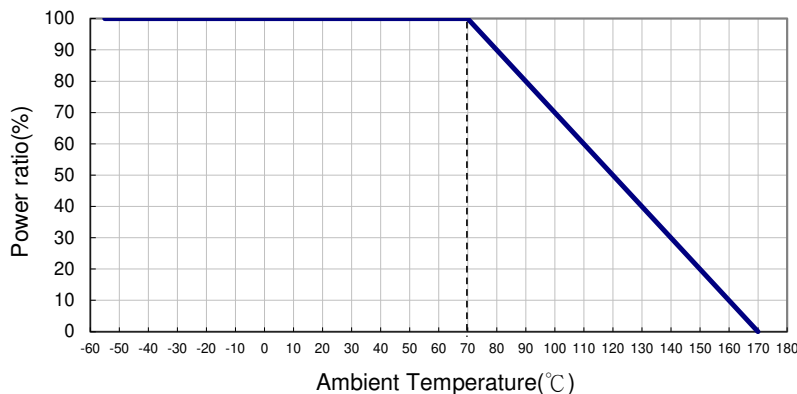

■ Measurements

1. LR12 4-wire precision measurement (Black Coating)

- Equipment: ADEX AX-1152D DC Low Ohm Meter
- Excitation Current: 3A (0.5mΩ~1.5 mΩ)
1A (2mΩ~10mΩ)

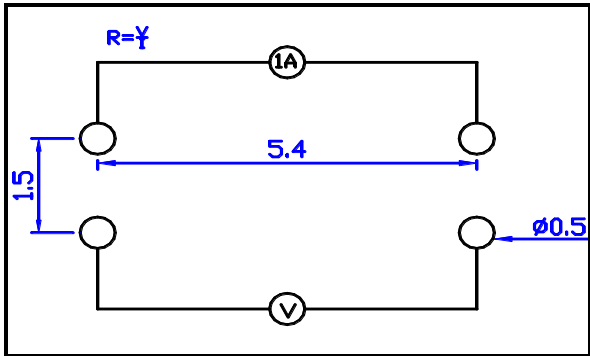

Unit: mm

2. LR12 4-wire pad layout (recommended for precision current sensing)

- Note: No circuits between pads to avoid short circuit

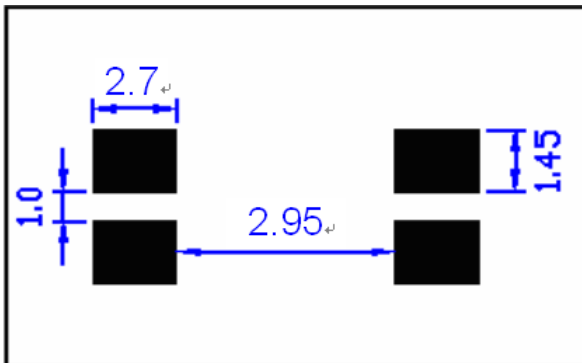

Unit: mm

3. LR12 2-wire pad layout

- Note: No circuits between pads to avoid short circuit

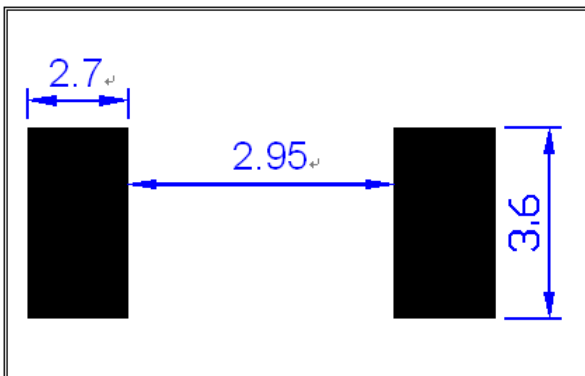

Unit: mm

4. LR12 4-wire precision measurement (Green Coating)

- Equipment: ADEX AX-1152D DC Low Ohm Meter
- Excitation Current: 3A (0.5mΩ~1.5 mΩ)
1A (2mΩ~10mΩ)

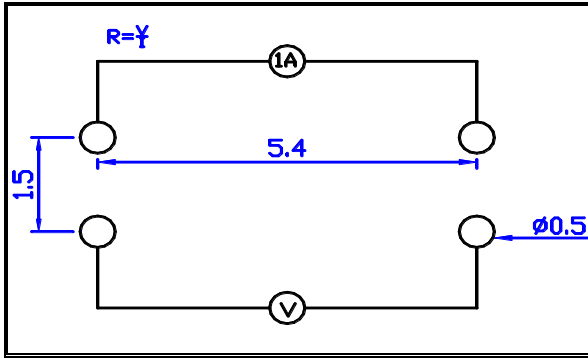

Unit: mm

5. LR12 4-wire pad layout (recommended for precision current sensing)

- Note: No circuits between pads to avoid short circuit

Unit: mm

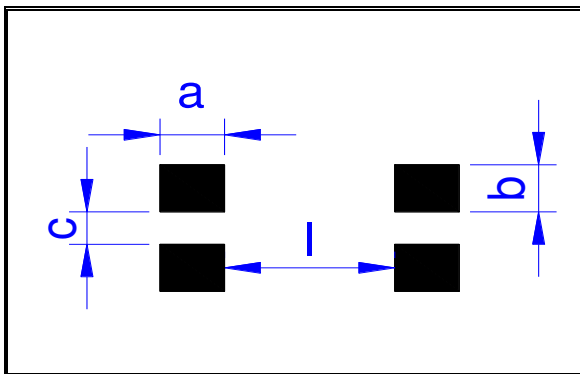

Item Type	a m/m	b m/m	C m/m	l m/m
0M50	3.13	1.2	1.0	0.52
0M75	2.93	1.2	1.0	0.94
R001	2.38	1.2	1.0	2.04
1M5	1.88	1.2	1.0	3.04
R002~3M5	1.63	1.2	1.0	3.54
R004~4M5	2.63	1.2	1.0	1.54
R005~R006	2.38	1.2	1.0	2.04
6M5~R007	1.88	1.2	1.0	3.04
R008~R010	1.63	1.2	1.0	3.54

6. LR12 2-wire pad layout

- Note: No circuits between pads to avoid short circuit

Unit: mm

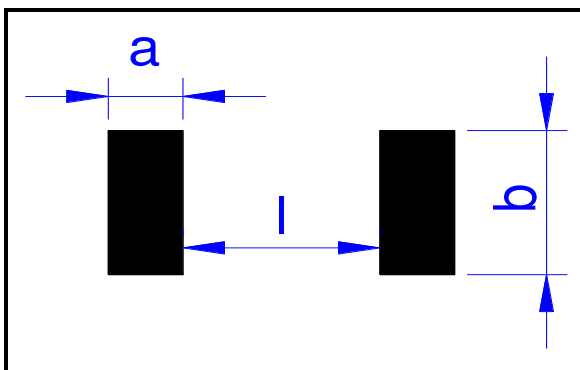

Item Type	a m/m	b m/m	l m/m
0M50	3.13	3.4	0.52
0M75	2.93	3.4	0.94
R001	2.38	3.4	2.04
1M5	1.88	3.4	3.04
R002~3M5	1.63	3.4	3.54
R004~4M5	2.63	3.4	1.54
R005~R006	2.38	3.4	2.04
6M5~R007	1.88	3.4	3.04
R008~R010	1.63	3.4	3.54

7. LR06 4-wire precision measurement

- Equipment: ADEX AX-1152D DC Low Ohm Meter
- Excitation Current: 1A (0.5mΩ~10mΩ)

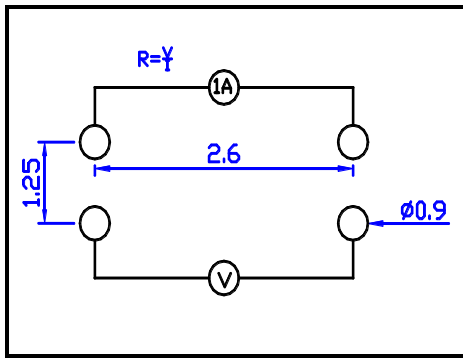

Unit: mm

8. LR06 4-wire pad layout (recommended for precision current sensing)

- Note: No circuits between pads to avoid short circuit

Unit: mm

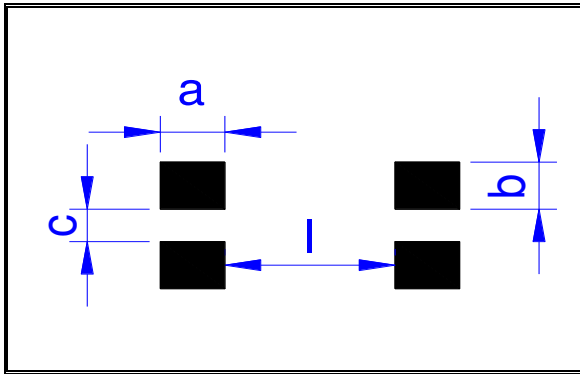

Item Type	a m/m	b m/m	c m/m	l m/m
0M50	1.80	0.7	0.5	0.55
0M75	1.68	0.7	0.5	0.55
R001	1.55	0.7	0.5	0.55
1M2	1.35	0.7	0.5	0.95
1M5	1.35	0.7	0.5	1.55
R002~R003	1.05	0.7	0.5	1.55
3M5~R006	1.55	0.7	0.5	0.55
R007~R009	1.35	0.7	0.5	0.95
R010	1.05	0.7	0.5	1.55

9. LR06 2-wire pad layout

- Note: No circuits between pads to avoid short circuit

Unit: mm

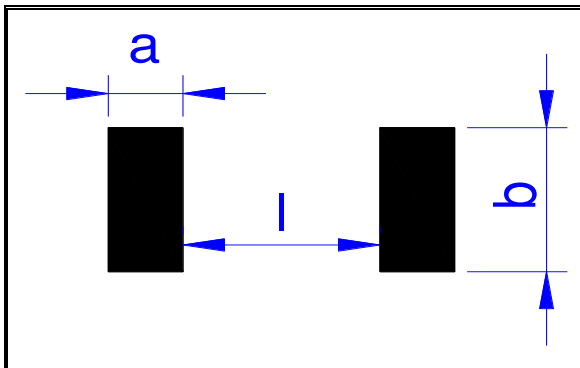

Item Type	a m/m	b m/m	l m/m
0M50	1.80	1.90	0.55
0M75	1.68	1.90	0.55
R001	1.55	1.89	0.55
1M2	1.35	1.90	0.95
1M5	1.35	1.89	1.55
R002~R003	1.05	1.89	1.55
3M5~R006	1.55	1.89	0.55
R007~R009	1.35	1.89	0.95
R010	1.05	1.89	1.55

10. LR10 4-wire precision measurement

- Equipment: ADEX AX-1152D DC Low Ohm Meter
- Excitation Current: 1A (0.5mΩ~10mΩ)

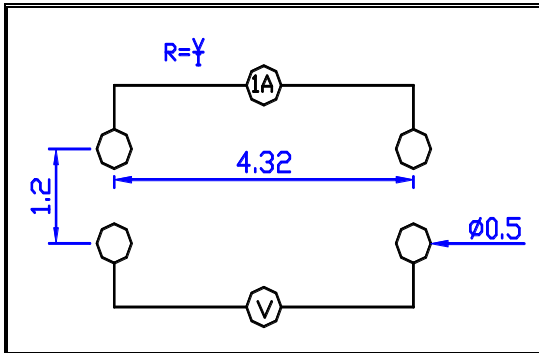

Unit: mm

11. LR10 4-wire pad layout (recommended for precision current sensing)

- Note: No circuits between pads to avoid short circuit

Unit: mm

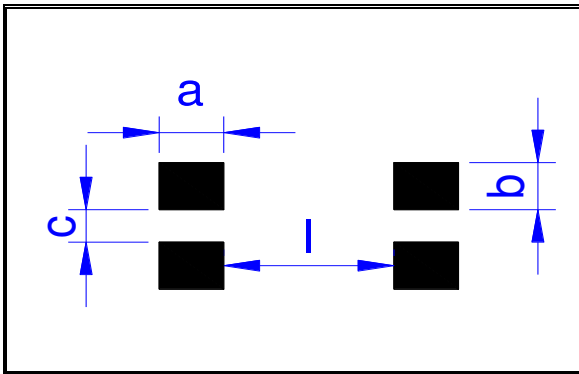

Item Type	a m/m	b m/m	c m/m	l m/m
0M50	2.61	1.045	0.8	0.60
0M75	2.49	1.045	0.8	0.80
R001~1M5	2.29	1.045	0.8	0.95
R002	1.99	1.045	0.8	1.55
R003~3M5	1.49	1.045	0.8	2.55
R004~5M5	2.29	1.045	0.8	0.95
R006~R008	1.99	1.045	0.8	1.55
R009~R010	1.74	1.045	0.8	2.05

12. LR10 2-wire pad layout

- Note: No circuits between pads to avoid short circuit

Unit: mm

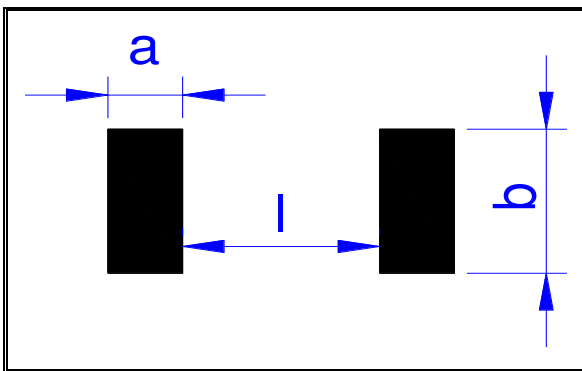

Item Type	a m/m	b m/m	l m/m
0M50	2.61	2.89	0.60
0M75	2.49	2.89	0.80
R001~1M5	2.29	2.89	0.95
R002	1.99	2.89	1.55
R003~3M5	1.49	2.89	2.55
R004~5M5	2.29	2.89	0.95
R006~R008	1.99	2.89	1.55
R009~R010	1.74	2.89	2.05

■ Packaging

Embossed Plastic Tape Specifications

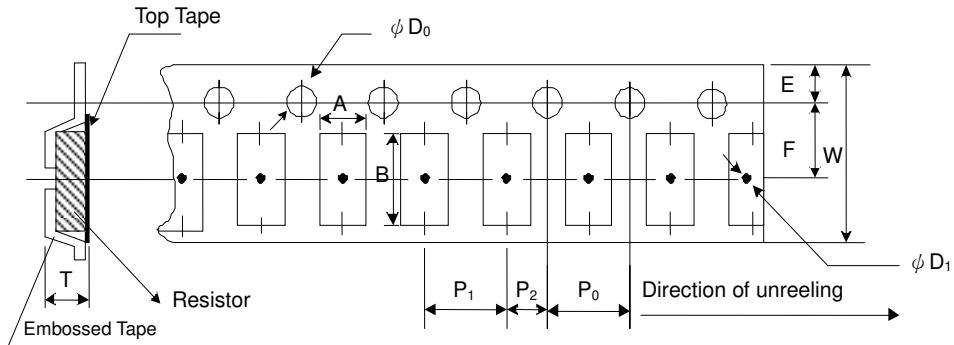

Unit: mm

Type	Resistance (mΩ)	A	B	W	E	F	P ₀	P ₁	P ₂	ΦD ₀	ΦD ₁	T	Quantity (EA)
LR06	0.5 - 10	1.90±0.1	3.60±0.1	8.0±0.2	1.75±0.1	3.5±0.05	4.0±0.1	4.0±0.1	2.0±0.05	1.55±0.05	1.0min.	0.87±0.1	2,000
LR10	0.5 - 10	2.85±0.1	5.55±0.1	12.0±0.2	1.75±0.1	5.5±0.05	4.0±0.1	4.0±0.1	2.0±0.05	1.55±0.05	1.4min.	0.85±0.1	2,000
LR12	0.50 - 0.75	3.40±0.1	6.75±0.1	12.0±0.1	1.75±0.1	5.5±0.05	4.0±0.1	4.0±0.1	2.0±0.05	1.55±0.05	1.4min.	1.45±0.2	2,000
	1 - 10											0.81±0.1	
LR12 (G)	0.50 - 10	3.40±0.1	6.75±0.1	12.0±0.1	1.75±0.1	5.5±0.05	4.0±0.1	4.0±0.1	2.0±0.05	1.55±0.05	1.4min.	0.81±0.1	2,000

1. The cumulative tolerance of 10 sprockets hole pitch is ± 0.2mm.
2. Carrier camber shall be not more than 1mm per 100mm through a length of 250mm.
3. A & B measured 0.3mm from the bottom of the packet
4. T measured at a point on the inside bottom of the packet to the top surface of the carrier.
5. Pocket position relative to sprocket hole is measured as the true position of the pocket and not the pocket hole.