

## 256K (32K x 8) Static RAM

### Features

- **High speed**
  - 55 ns
- **Temperature Ranges**
  - Commercial: 0°C to 70°C
  - Industrial: -40°C to 85°C
  - Automotive: -40°C to 125°C
- **Voltage range**
  - 4.5V – 5.5V
- **Low active power and standby power**
- **Easy memory expansion with  $\overline{CE}$  and  $\overline{OE}$  features**
- **TTL-compatible inputs and outputs**
- **Automatic power-down when deselected**
- **CMOS for optimum speed/power**
- **Available in a Pb-free and non Pb-free standard 28-pin narrow SOIC, 28-pin TSOP-1, 28-pin Reverse TSOP-1 and 28-pin DIP packages**

### Functional Description<sup>[1]</sup>

The CY62256 is a high-performance CMOS static RAM organized as 32K words by 8 bits. Easy memory expansion is provided by an active LOW chip enable ( $\overline{CE}$ ) and active LOW output enable ( $\overline{OE}$ ) and Tri-state drivers. This device has an automatic power-down feature, reducing the power consumption by 99.9% when deselected.

An active LOW write enable signal ( $\overline{WE}$ ) controls the writing/reading operation of the memory. When  $\overline{CE}$  and  $\overline{WE}$  inputs are both LOW, data on the eight data input/output pins ( $I/O_0$  through  $I/O_7$ ) is written into the memory location addressed by the address present on the address pins ( $A_0$  through  $A_{14}$ ). Reading the device is accomplished by selecting the device and enabling the outputs,  $\overline{CE}$  and  $\overline{OE}$  active LOW, while  $\overline{WE}$  remains inactive or HIGH. Under these conditions, the contents of the location addressed by the information on address pins are present on the eight data input/output pins.

The input/output pins remain in a high-impedance state unless the chip is selected, outputs are enabled, and write enable ( $\overline{WE}$ ) is HIGH.

### Logic Block Diagram

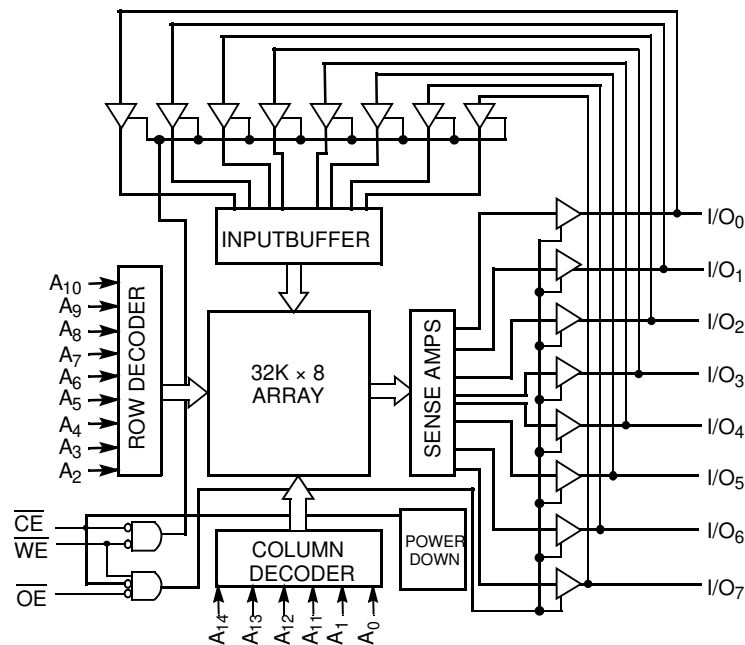

**Note:**

1. For best practice recommendations, please refer to the Cypress application note "System Design Guidelines" on <http://www.cypress.com>.

Product Portfolio

Product		V <sub>CC</sub> Range (V)			Speed (ns)	Power Dissipation			
						Operating, I <sub>CC</sub> (mA)		Standby, I <sub>SB2</sub> (μA)	
		Min.	Typ. <sup>[2]</sup>	Max.		Typ. <sup>[2]</sup>	Max.	Typ. <sup>[2]</sup>	Max.
CY62256L	Com'I/Ind'I	4.5	5.0	5.5	55/70	25	50	2	50
CY62256LL	Commercial				70	25	50	0.1	5
CY62256LL	Industrial				55/70	25	50	0.1	10
CY62256LL	Automotive				55	25	50	0.1	15

Pin Configurations

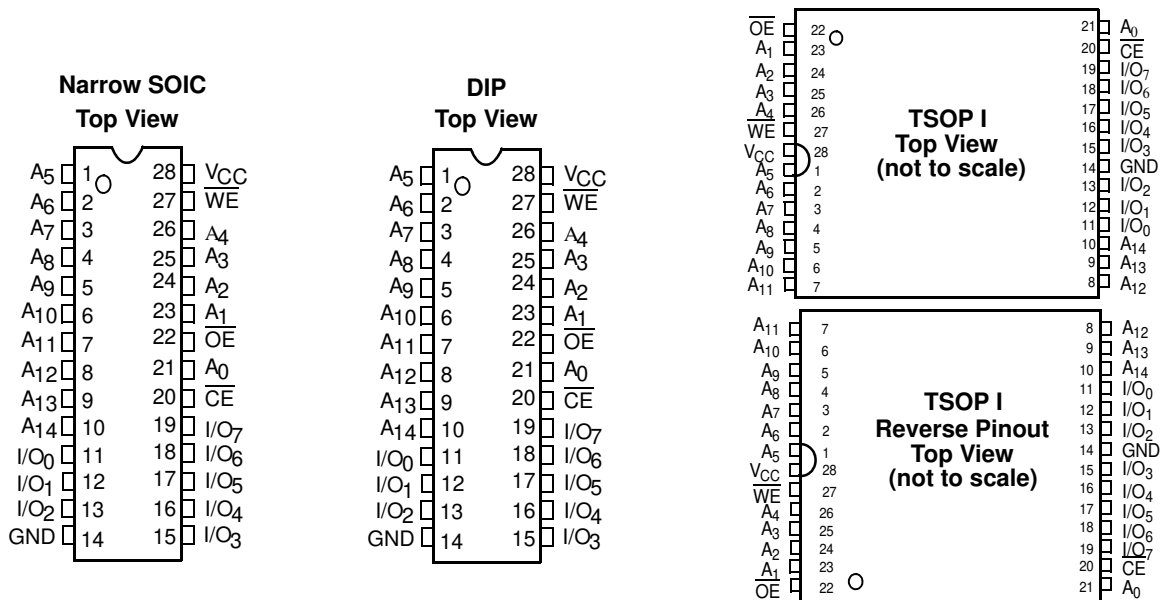

Pin Definitions

Pin Number	Type	Description
1–10, 21, 23–26	Input	A <sub>0</sub> –A <sub>14</sub> . Address Inputs
11–13, 15–19,	Input/Output	I/O <sub>0</sub> –I/O <sub>7</sub> . Data lines. Used as input or output lines depending on operation
27	Input/Control	WE. When selected LOW, a WRITE is conducted. When selected HIGH, a READ is conducted
20	Input/Control	CE. When LOW, selects the chip. When HIGH, deselects the chip
22	Input/Control	OE. Output Enable. Controls the direction of the I/O pins. When LOW, the I/O pins behave as outputs. When deasserted HIGH, I/O pins are Tri-stated, and act as input data pins
14	Ground	GND. Ground for the device
28	Power Supply	V <sub>CC</sub> . Power supply for the device

Note:

2. Typical specifications are the mean values measured over a large sample size across normal production process variations and are taken at nominal conditions (T<sub>A</sub> = 25°C, V<sub>CC</sub>). Parameters are guaranteed by design and characterization, and not 100% tested.

**Maximum Ratings**

(Above which the useful life may be impaired. For user guidelines, not tested.)

Storage Temperature ..... -65°C to +150°C  
 Ambient Temperature with Power Applied..... -55°C to +125°C  
 Supply Voltage to Ground Potential (Pin 28 to Pin 14) ..... -0.5V to +7V  
 DC Voltage Applied to Outputs in High-Z State<sup>[3]</sup> ..... -0.5V to  $V_{CC} + 0.5V$

DC Input Voltage<sup>[3]</sup> ..... -0.5V to  $V_{CC} + 0.5V$   
 Output Current into Outputs (LOW)..... 20 mA  
 Static Discharge Voltage..... > 2001V (per MIL-STD-883, Method 3015)  
 Latch-up Current..... > 200 mA

**Operating Range**

Range	Ambient Temperature ( $T_A$ ) <sup>[4]</sup>	$V_{CC}$
Commercial	0°C to +70°C	5V ± 10%
Industrial	-40°C to +85°C	5V ± 10%
Automotive	-40°C to +125°C	5V ± 10%

**Electrical Characteristics** Over the Operating Range

Parameter	Description	Test Conditions	CY62256-55			CY62256-70			Unit	
			Min.	Typ. <sup>[2]</sup>	Max.	Min.	Typ. <sup>[2]</sup>	Max.		
$V_{OH}$	Output HIGH Voltage	$V_{CC} = \text{Min.}, I_{OH} = -1.0 \text{ mA}$	2.4			2.4			V	
$V_{OL}$	Output LOW Voltage	$V_{CC} = \text{Min.}, I_{OL} = 2.1 \text{ mA}$			0.4			0.4	V	
$V_{IH}$	Input HIGH Voltage		2.2		$V_{CC} + 0.5V$	2.2		$V_{CC} + 0.5V$	V	
$V_{IL}$	Input LOW Voltage		-0.5		0.8	-0.5		0.8	V	
$I_{IX}$	Input Leakage Current	$GND \leq V_I \leq V_{CC}$	-0.5		+0.5	-0.5		+0.5	μA	
$I_{OZ}$	Output Leakage Current	$GND \leq V_O \leq V_{CC}$ , Output Disabled	-0.5		+0.5	-0.5		+0.5	μA	
$I_{CC}$	$V_{CC}$ Operating Supply Current	$V_{CC} = 5.5V$ , $I_{OUT} = 0 \text{ mA}$ , $f = f_{Max} = 1/t_{RC}$	L		25	50		25	50	mA
			LL		25	50		25	50	
$I_{SB1}$	Automatic CE Power-down Current—TTL Inputs	$V_{CC} = 5.5V$ , $\overline{CE} \geq V_{IH}$ , $V_{IN} \geq V_{IH}$ or $V_{IN} \leq V_{IL}$ , $f = f_{Max}$	L		0.4	0.6		0.4	0.6	mA
			LL		0.3	0.5		0.3	0.5	
$I_{SB2}$	Automatic CE Power-down Current—CMOS Inputs	$V_{CC} = 5.5V$ , $\overline{CE} \geq V_{CC} - 0.3V$ , $V_{IN} \geq V_{CC} - 0.3V$ , or $V_{IN} \leq 0.3V$ , $f = 0$	L		2	50		2	50	μA
			LL - Com'l		0.1	5		0.1	5	
			LL - Ind'l		0.1	10		0.1	10	
			LL - Auto		0.1	15				

**Capacitance<sup>[5]</sup>**

Parameter	Description	Test Conditions	Max.	Unit
$C_{IN}$	Input Capacitance	$T_A = 25^\circ\text{C}$ , $f = 1 \text{ MHz}$ , $V_{CC} = V_{CC}(\text{typ.})$	6	pF
$C_{OUT}$	Output Capacitance		8	pF

**Thermal Resistance<sup>[5]</sup>**

Parameter	Description	Test Conditions	DIP	SOIC	TSOP	RTSOP	Unit
$\theta_{JA}$	Thermal Resistance (Junction to Ambient)	Still Air, soldered on a 4.25 x 1.125 inch, 2-layer printed circuit board	75.61	76.56	93.89	93.89	°C/W
$\theta_{JC}$	Thermal Resistance (Junction to Case)		43.12	36.07	24.64	24.64	°C/W

**Notes:**

- $V_{IL}$  (min.) = -2.0V for pulse durations of less than 20 ns.
- $T_A$  is the "Instant-On" case temperature.
- Tested initially and after any design or process changes that may affect these parameters.

### AC Test Loads and Waveforms

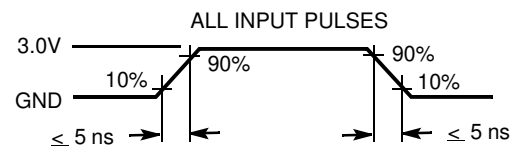
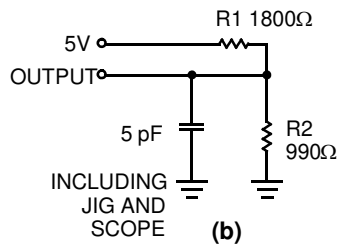
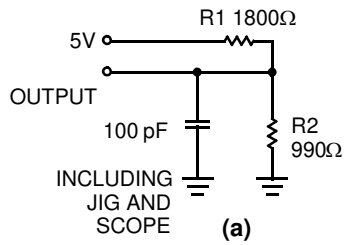

Equivalent to: THEVENIN EQUIVALENT

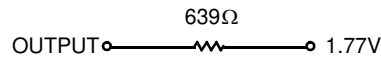

### Data Retention Characteristics

Parameter	Description	Conditions <sup>[6]</sup>	Min.	Typ. <sup>[2]</sup>	Max.	Unit
$V_{DR}$	$V_{CC}$ for Data Retention		2.0			V
$I_{CCDR}$	Data Retention Current	L	$V_{CC} = 2.0V, \overline{CE} \geq V_{CC} - 0.3V,$ $V_{IN} \geq V_{CC} - 0.3V, \text{ or } V_{IN} \leq 0.3V$	2	50	$\mu A$
		LL - Com'l		0.1	5	$\mu A$
		LL - Ind'l		0.1	10	$\mu A$
		LL - Auto		0.1	10	$\mu A$
$t_{CDR}^{[5]}$	Chip Deselect to Data Retention Time		0			ns
$t_R^{[5]}$	Operation Recovery Time		$t_{RC}$			ns

### Data Retention Waveform

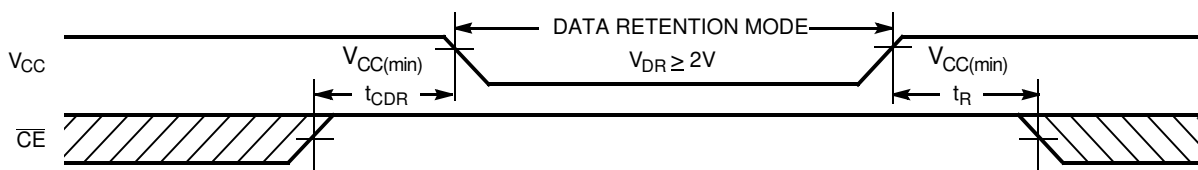

**Note:**

6. No input may exceed  $V_{CC} + 0.5V$ .

**Switching Characteristics** Over the Operating Range<sup>[7]</sup>

Parameter	Description	CY62256-55		CY62256-70		Unit
		Min.	Max.	Min.	Max.	
<b>Read Cycle</b>						
$t_{RC}$	Read Cycle Time	55		70		ns
$t_{AA}$	Address to Data Valid		55		70	ns
$t_{OHA}$	Data Hold from Address Change	5		5		ns
$t_{ACE}$	$\overline{CE}$ LOW to Data Valid		55		70	ns
$t_{DOE}$	$\overline{OE}$ LOW to Data Valid		25		35	ns
$t_{LZOE}$	$\overline{OE}$ LOW to Low-Z <sup>[8]</sup>	5		5		ns
$t_{HZOE}$	$\overline{OE}$ HIGH to High-Z <sup>[8, 9]</sup>		20		25	ns
$t_{LZCE}$	$\overline{CE}$ LOW to Low-Z <sup>[8]</sup>	5		5		ns
$t_{HZCE}$	$\overline{CE}$ HIGH to High-Z <sup>[8, 9]</sup>		20		25	ns
$t_{PU}$	$\overline{CE}$ LOW to Power-up	0		0		ns
$t_{PD}$	$\overline{CE}$ HIGH to Power-down		55		70	ns
<b>Write Cycle<sup>[10, 11]</sup></b>						
$t_{WC}$	Write Cycle Time	55		70		ns
$t_{SCE}$	$\overline{CE}$ LOW to Write End	45		60		ns
$t_{AW}$	Address Set-up to Write End	45		60		ns
$t_{HA}$	Address Hold from Write End	0		0		ns
$t_{SA}$	Address Set-up to Write Start	0		0		ns
$t_{PWE}$	$\overline{WE}$ Pulse Width	40		50		ns
$t_{SD}$	Data Set-up to Write End	25		30		ns
$t_{HD}$	Data Hold from Write End	0		0		ns
$t_{HZWE}$	$\overline{WE}$ LOW to High-Z <sup>[8, 9]</sup>		20		25	ns
$t_{LZWE}$	$\overline{WE}$ HIGH to Low-Z <sup>[8]</sup>	5		5		ns

**Notes:**

7. Test conditions assume signal transition time of 5 ns or less, timing reference levels of 1.5V, input pulse levels of 0 to 3.0V, and output loading of the specified  $I_{OL}/I_{OH}$  and 100 pF load capacitance.
8. At any given temperature and voltage condition,  $t_{HZCE}$  is less than  $t_{LZCE}$ ,  $t_{HZOE}$  is less than  $t_{LZOE}$ , and  $t_{HZWE}$  is less than  $t_{LZWE}$  for any given device.
9.  $t_{HZOE}$ ,  $t_{HZCE}$ , and  $t_{HZWE}$  are specified with  $C_L = 5$  pF as in (b) of AC Test Loads. Transition is measured  $\pm 500$  mV from steady-state voltage.
10. The internal Write time of the memory is defined by the overlap of  $\overline{CE}$  LOW and  $\overline{WE}$  LOW. Both signals must be LOW to initiate a Write and either signal can terminate a Write by going HIGH. The data input set-up and hold timing should be referenced to the rising edge of the signal that terminates the Write.
11. The minimum Write cycle time for Write Cycle #3 ( $\overline{WE}$  controlled,  $\overline{OE}$  LOW) is the sum of  $t_{HZWE}$  and  $t_{SD}$ .

### Switching Waveforms

#### Read Cycle No. 1 (Address Transition Controlled)<sup>[12, 13]</sup>

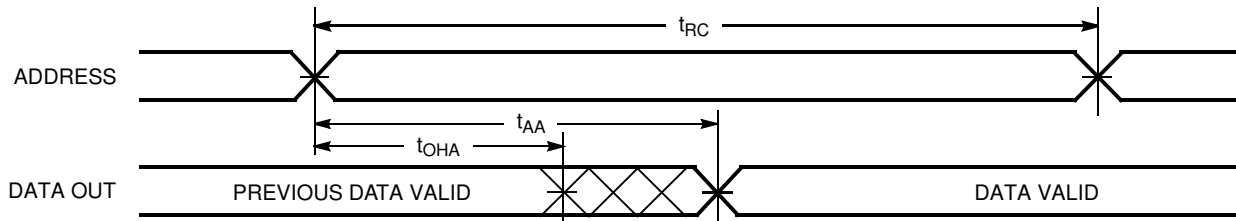

#### Read Cycle No. 2 ( $\overline{OE}$ Controlled)<sup>[13, 14]</sup>

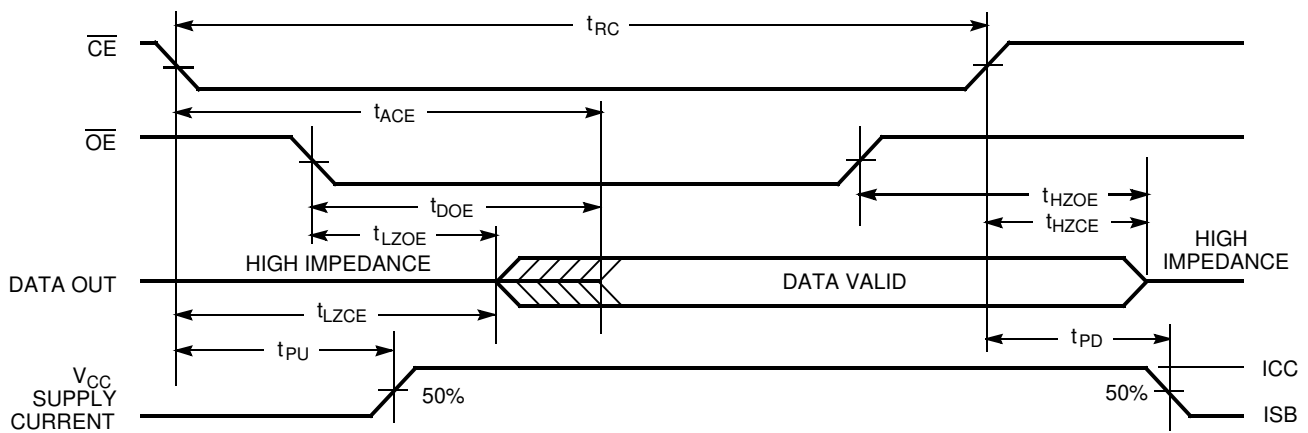

#### Write Cycle No. 1 ( $\overline{WE}$ Controlled)<sup>[10, 15, 16]</sup>

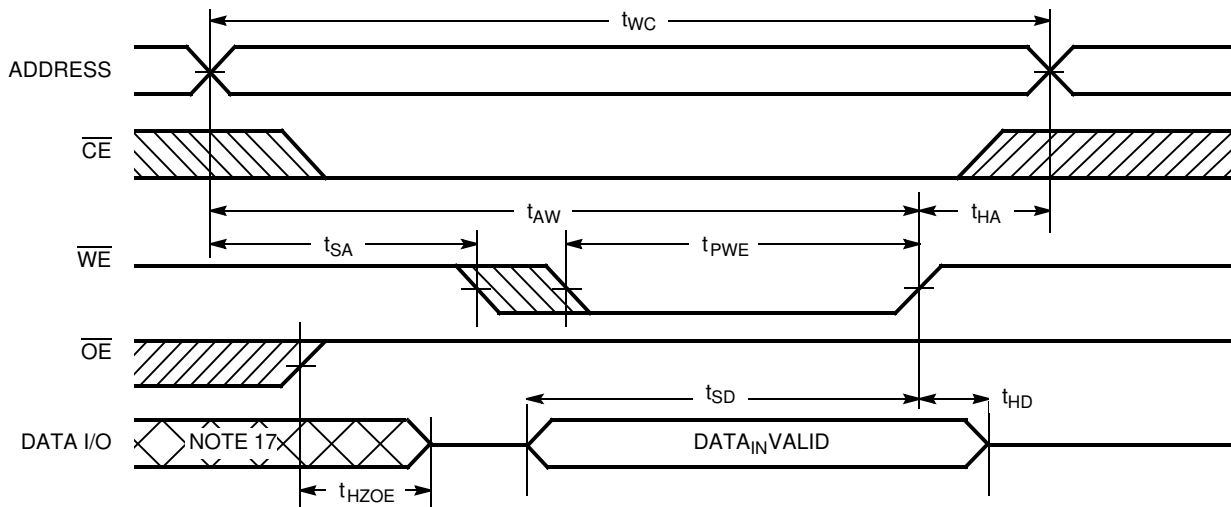

**Notes:**

- 12. Device is continuously selected.  $\overline{OE}$ ,  $\overline{CE}$  =  $V_{IL}$ .
- 13.  $\overline{WE}$  is HIGH for Read cycle.
- 14. Address valid prior to or coincident with  $\overline{CE}$  transition LOW.
- 15. Data I/O is high impedance if  $\overline{OE}$  =  $V_{IH}$ .
- 16. If  $\overline{CE}$  goes HIGH simultaneously with  $\overline{WE}$  HIGH, the output remains in a high-impedance state.
- 17. During this period, the I/Os are in output state and input signals should not be applied.

Switching Waveforms (continued)

Write Cycle No. 2 ( $\overline{\text{CE}}$  Controlled)<sup>[10, 15, 16]</sup>

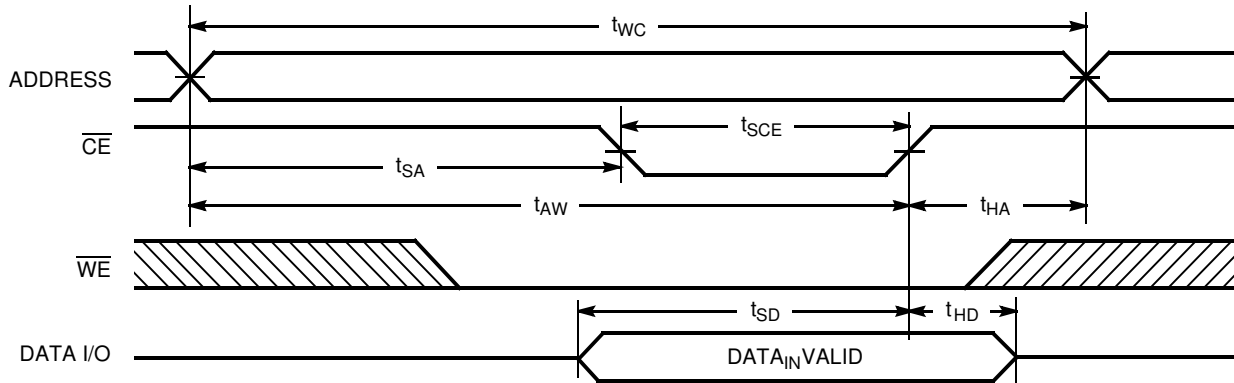

Write Cycle No. 3 ( $\overline{\text{WE}}$  Controlled,  $\overline{\text{OE}}$  LOW)<sup>[11, 16]</sup>

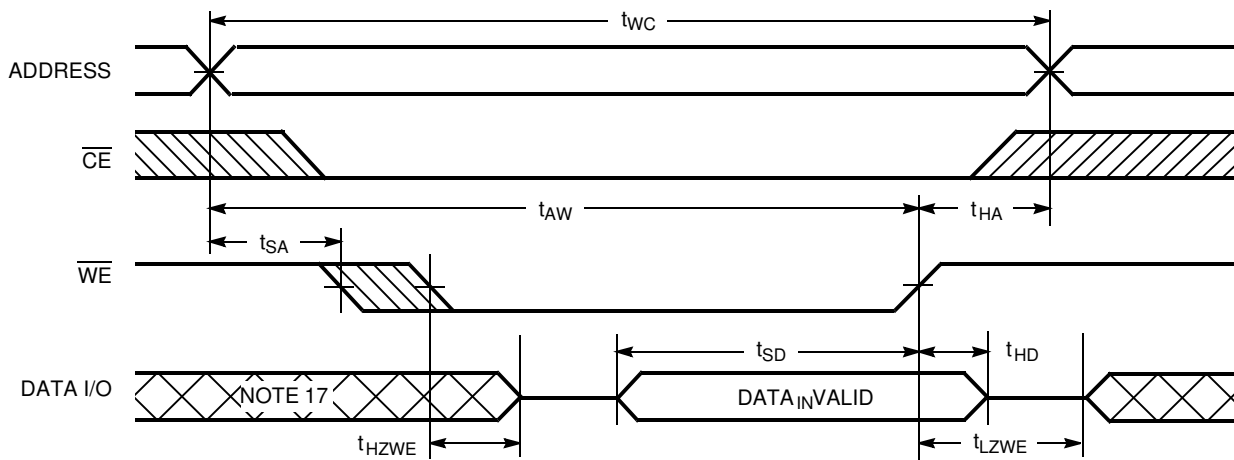

**Typical DC and AC Characteristics**

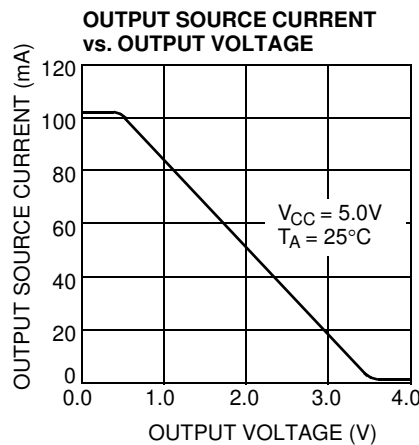
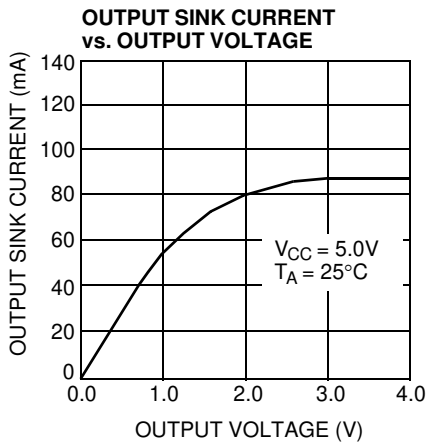
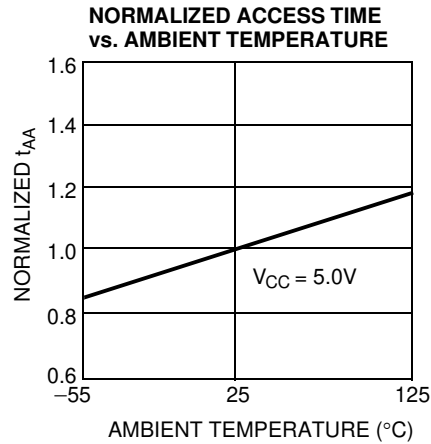
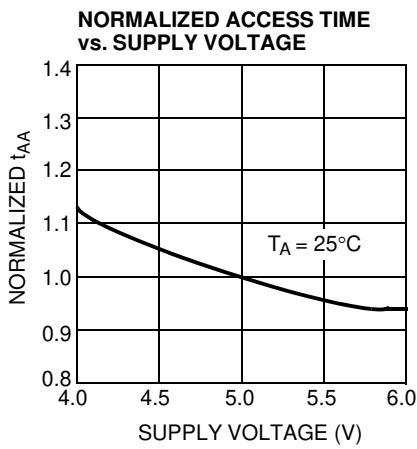
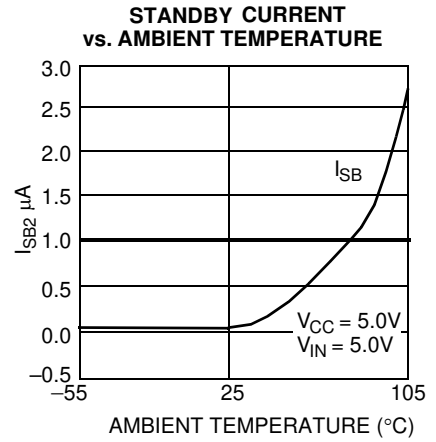
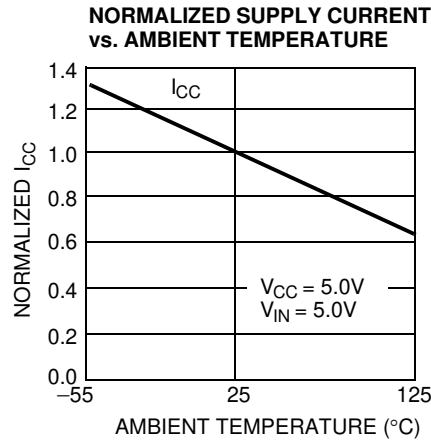
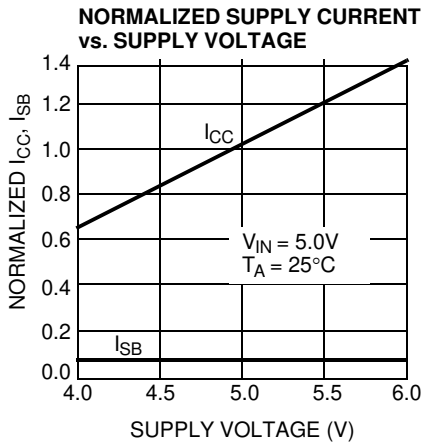



Typical DC and AC Characteristics (continued)

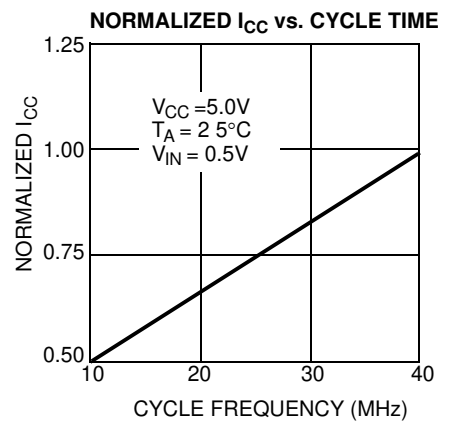
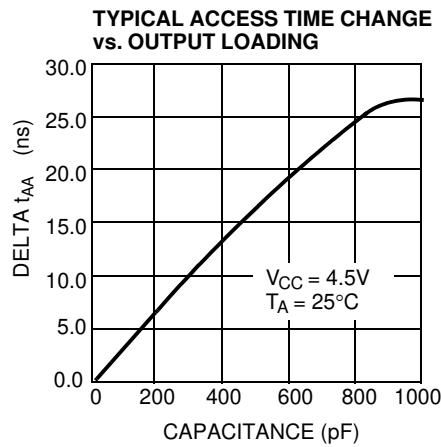
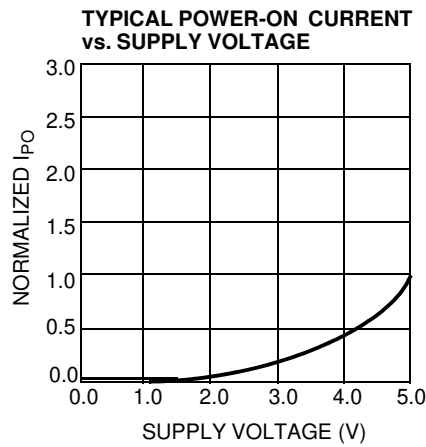

Truth Table

$\overline{CE}$	$\overline{WE}$	$\overline{OE}$	Inputs/Outputs	Mode	Power
H	X	X	High-Z	Deselect/Power-down	Standby ( $I_{SB}$ )
L	H	L	Data Out	Read	Active ( $I_{CC}$ )
L	L	X	Data In	Write	Active ( $I_{CC}$ )
L	H	H	High-Z	Output Disabled	Active ( $I_{CC}$ )

**Ordering Information**

Speed (ns)	Ordering Code	Package Diagram	Package Type	Operating Range	
55	CY62256LL-55SNI	51-85092	28-pin (300-mil Narrow Body) SNC	Industrial	
	CY62256LL-55SNXI		28-pin (300-mil Narrow Body) SNC (Pb-free)		
	CY62256LL-55ZXI	51-85071	28-pin TSOP I (Pb-free)		
	CY62256LL-55SNE	51-85092	28-pin (300-mil Narrow Body) SNC		Automotive
	CY62256LL-55SNXE		28-pin (300-mil Narrow Body) SNC (Pb-free)		
	CY62256LL-55ZE	51-85071	28-pin TSOP I		
	CY62256LL-55ZXE		28-pin TSOP I (Pb-free)		
	CY62256LL-55ZRXE	51-85074	28-pin Reverse TSOP I (Pb-free)		
70	CY62256LL-70PC	51-85017	28-pin (600-Mil) Molded DIP	Commercial	
	CY62256LL-70PXC		28-pin (600-Mil) Molded DIP (Pb-free)		
	CY62256L-70SNC	51-85092	28-pin (300-mil Narrow Body) SNC		
	CY62256L-70SNXC		28-pin (300-mil Narrow Body) SNC (Pb-free)		
	CY62256LL-70SNC		28-pin (300-mil Narrow Body) SNC		
	CY62256LL-70SNXC		28-pin (300-mil Narrow Body) SNC (Pb-free)		
	CY62256LL-70ZC	51-85071	28-pin TSOP I		
	CY62256LL-70ZXC		28-pin TSOP I (Pb-free)		
	CY62256L-70SNI	51-85092	28-pin (300-mil Narrow Body) SNC	Industrial	
	CY62256L-70SNXI		28-pin (300-mil Narrow Body) SNC (Pb-free)		
	CY62256LL-70SNI		28-pin (300-mil Narrow Body) SNC		
	CY62256LL-70SNXI		28-pin (300-mil Narrow Body) SNC (Pb-free)		
	CY62256LL-70ZXI	51-85071	28-pin TSOP I (Pb-free)		
	CY62256LL-70ZRI	51-85074	28-pin Reverse TSOP I		
	CY62256LL-70ZRXI		28-pin Reverse TSOP I (Pb-free)		

Please contact your local Cypress sales representative for availability of these parts

**Package Diagrams**

**28-pin (600-mil) Molded DIP (51-85017)**

DIMENSIONS IN INCHES

MIN.  
MAX.

REFERENCE JEDEC Ms-020

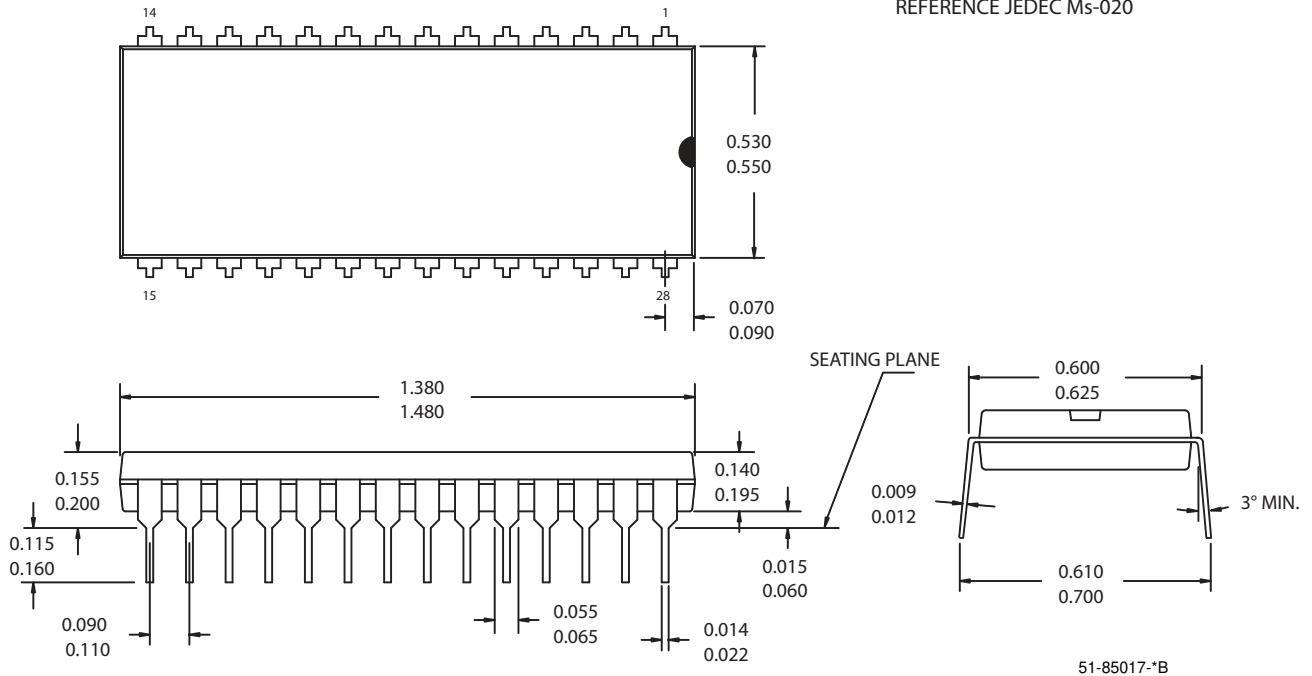

**28-pin (300-mil) SNC (Narrow Body) (51-85092)**

DIMENSIONS IN INCHES

MIN.  
MAX.

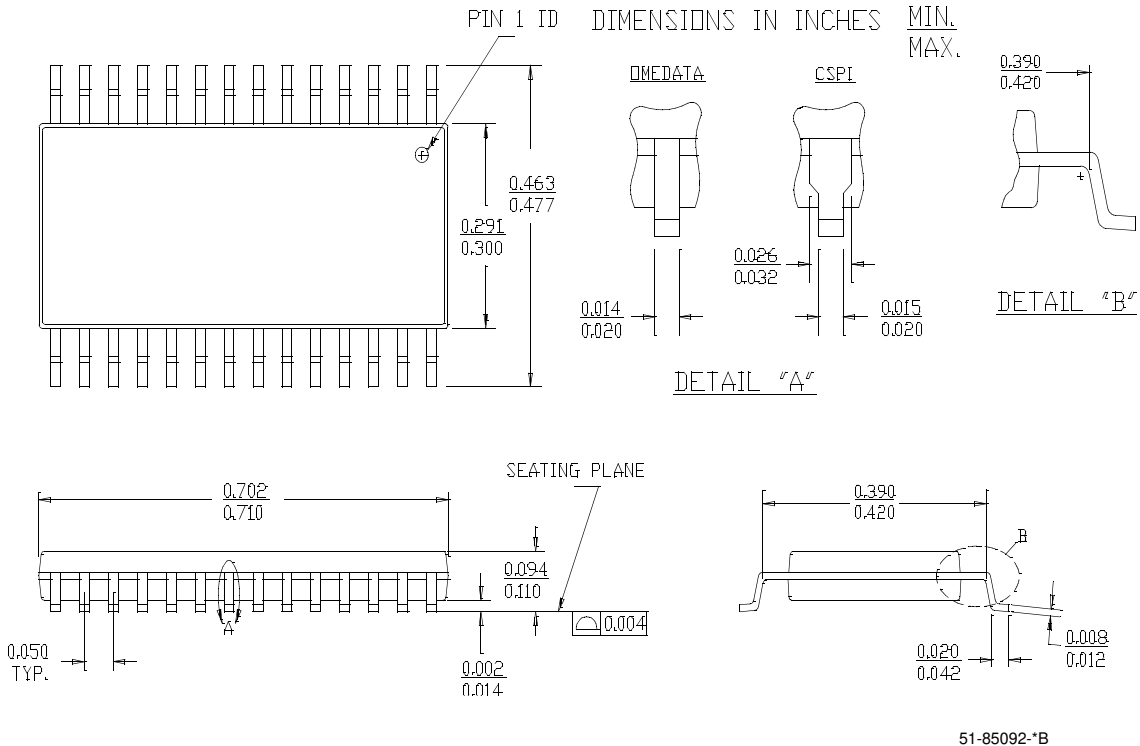

Package Diagrams (continued)

28-pin Thin Small Outline Package Type 1 (8 x 13.4 mm) (51-85071)

NOTE: ORIENTATION ID MAY BE LOCATED EITHER AS SHOWN IN OPTION 1 OR OPTION 2

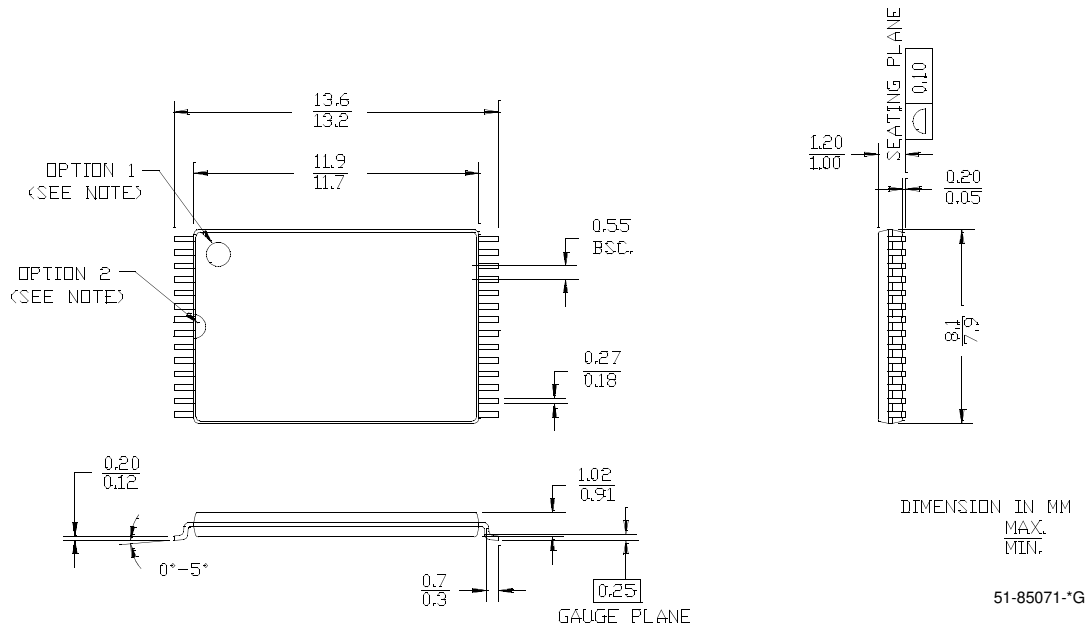

Package Diagrams (continued)

28-pin Reverse Thin Small Outline Package Type 1 (8x13.4 mm) (51-85074)

NOTE: ORIENTATION I.D. MAY BE LOCATED EITHER AS SHOWN IN OPTION 1 OR OPTION 2

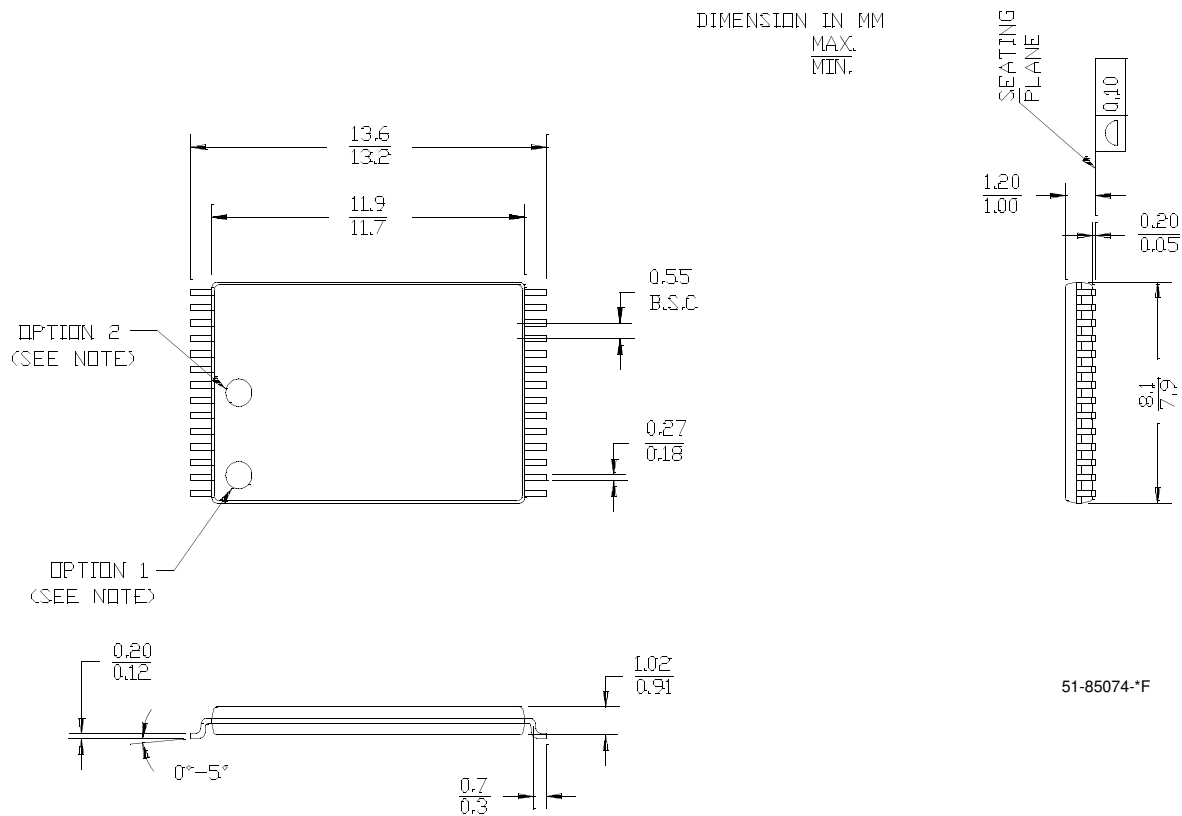

All product and company names mentioned in this document are the trademarks of their respective holders.

**Document History Page**

<b>Document Title: CY62256, 256K (32K x 8) Static RAM</b>				
<b>Document Number: 38-05248</b>				
<b>REV.</b>	<b>ECN NO.</b>	<b>Issue Date</b>	<b>Orig. of Change</b>	<b>Description of Change</b>
**	113454	03/06/02	MGN	Change from Spec number: 38-00455 to 38-05248 Remove obsolete parts from ordering info, standardize format
*A	115227	05/23/02	GBI	Changed SN Package Diagram
*B	116506	09/04/02	GBI	Added footnote 1 Corrected package description in Ordering Information table
*C	238448	See ECN	AJU	Added Automotive product information
*D	344595	See ECN	SYT	Added Pb-free packages on page# 10
*E	395936	See ECN	SYT	Changed address of Cypress Semiconductor Corporation on Page# 1 from "3901 North First Street" to "198 Champion Court" Added CY62256L-70SNXI package in the Ordering Information on Page # 10
*F	493277	See ECN	VKN	Updated Ordering Information table