

4

3

2

1

THIS DRAWING IS UNPUBLISHED. RELEASED FOR PUBLICATION
© COPYRIGHT ALL RIGHTS RESERVED.

LOC	DIST	REVISIONS			
P	LTR	DESCRIPTION	DATE	DWN	APVD
	A1	ECR-14-002312	17FEB2014	GK	HMR

REPLACED BY OCEAN STYLE APPLICATOR PART NUMBER 2151370-6

FOR REPLACEMENT PARTS FOR APPLICATOR 1911167 REFER TO ADDITIONAL PAGE(S). SPARE PARTS KIT (IF LISTED) WILL REMAIN AVAILABLE.

THE REPLACEMENT OCEAN STYLE APPLICATOR HAS THE SAME TERMINATOR/PRESS INTERFACE AS APPLICATOR 1911167

THIS DRAWING IS A CONTROLLED DOCUMENT.		DWN	GOPALAKRISHNA HV														
DIMENSIONS:		CHK	RAGHAVENDRA														
TOLERANCES UNLESS OTHERWISE SPECIFIED:		APVD	RAGHAVENDRA														
<table border="0"> <tr><td>0 PLC</td><td>±</td></tr> <tr><td>1 PLC</td><td>±</td></tr> <tr><td>2 PLC</td><td>±</td></tr> <tr><td>3 PLC</td><td>±</td></tr> <tr><td>4 PLC</td><td>±</td></tr> <tr><td>ANGLES</td><td>±</td></tr> </table>		0 PLC	±	1 PLC	±	2 PLC	±	3 PLC	±	4 PLC	±	ANGLES	±	NAME	END FEED SIII APPLICATOR		
0 PLC	±																
1 PLC	±																
2 PLC	±																
3 PLC	±																
4 PLC	±																
ANGLES	±																
MATERIAL		PRODUCT SPEC															
FINISH		APPLICATION SPEC															
		WEIGHT	SIZE	CAGE CODE	DRAWING NO												
			A3		©- 1911167												
		CUSTOMER DRAWING	SCALE	SHEET 1 OF 2	REV A1												

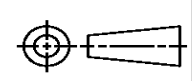

PART NUMBER		REV	DESCRIPTION	PROGRAMMED MEMORY CHIP
1911167-1		A	S3A APPLICATOR	8-1911167-1
7-1911167-1		A	-1 AND SPARE PARTS	9-1911167-1
7-1911167-7		A	SPARE PARTS KIT	

APPLICATOR DATA		
CRIMP	SIZE	TYPE
WIRE	3.30 [.130IN]	F
INSUL	5.33 [.210IN]	O
APPL INSTRUCTIONS 408-10136		

TERMINAL DATA: TE TERMINAL		TYCO ELECTRONICS CRIMP SPEC	
TERMINAL NAME: RECEPTACLE, FASTON, LOW-INSERTION, .250 SERIES			
WIRE STRIP LENGTH .210-.225 IN [.530-5.70mm]		INSULATION DIAMETER RANGE .150-.200 IN [.381-5.08mm]	
TERMINAL APPL SPEC	114-2036	-	-
TERMINALS APPLIED			
42437-2	41449-3	1-41450-1	63412-1
42437-5	41450	61095-1	63435-1
42437-6	41450-1	61095-4	63435-2
41449	41450-2	63365-1	1742399-1
41449-1	41450-3	63365-2	-

WIRE SIZE	CRIMP HEIGHT mm [INCH]
10AWG	2.92±.05 [.115±.002]
4mm ²	2.59±.05 [.102±.002]
3.5mm ²	2.46±.05 [.097±.002]
12AWG	2.41±.05 [.095±.002]
3mm ²	2.34±.05 [.092±.002]
2.5mm ²	2.21±.05 [.087±.002]
2.25mm ²	2.16±.05 [.085±.002]
14AWG	2.11±.05 [.083±.002]

- ⚠ RECOMMENDED SPARE PARTS.
- ⚡ GREASE BEARING SURFACES LIGHTLY.
- 3. LUBRICATE DAILY PER THE APPLICATOR INSTRUCTION SHEET SUPPLIED WITH THE APPLICATOR.
- 4. APPLY P/N 1-23419-5 LOCTITE® TO THREADS.
- 5. APPLICATOR SPECIFIC DATA TO BE ENTERED INTO BLANK MEMORY CHIP AT ASSEMBLY.

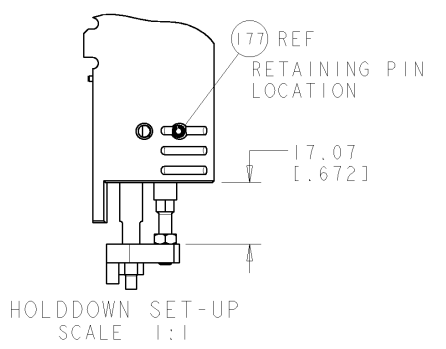
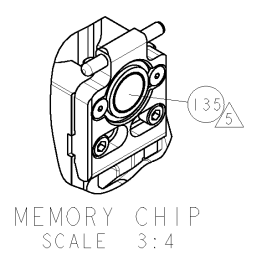
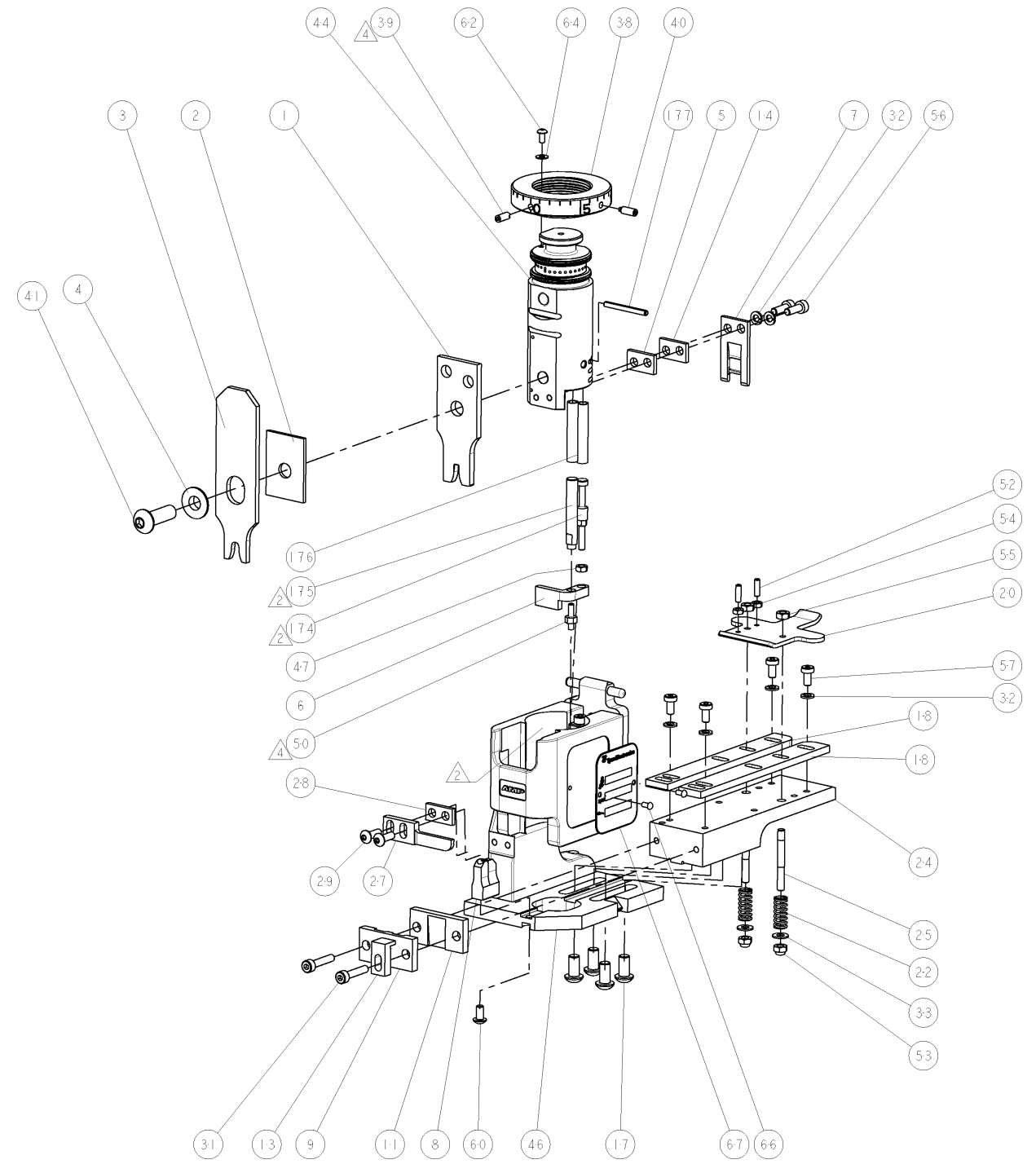

FEED FINGER 1901697-1	SET UP GAGE 1901068-1	LOC A	DIST 66	REVISIONS			
REV	DATE	BY	CHKD	DESCRIPTION	DATE	BY	CHKD
A	RELEASED				04JAN2008	BH	BH

-	1	1	1-993111-6	PIN, SLOTTED SPRING 3.0 X 30.0	177	
-	2	2	3-22280-7	SPRING, COMPRESSION	176	
-	1	1	1752353-1	GUIDE PIN, HOLDDOWN	175	
-	1	1	1901680-1	GUIDE PIN, HOLDDOWN	174	
REF	REF	REF	SEE TABLE	MEMORY CHIP, PROGRAMMED	135	
-	1	1	1633565-2	DOCUMENTATION PACKAGE	71	
-	1	1	1901048-1	TAG, IDENTIFICATION	67	
-	2	2	21017-2	SCREW, DRIVE	66	
-	1	1	18028-1	WASHER, FLAT, REG M3	64	
-	1	1	1655785-9	SCR, BTN SKT HD CAP (M3 X 6)	62	
-	1	1	1655785-1	SCR, BTN SKT HD CAP (M4 X 8)	60	
-	4	4	1655783-2	SCR, CAP, SOC HD, LOW HEAD, M4 X 8	57	
-	2	2	2-1655316-0	SCR, SKT HD CAP, M4 X 12.0	56	
-	2	2	18030-2	NUT, HEX, REG M4	55	
-	2	2	18030-1	NUT, HEX, REG M3	54	
-	2	2	986965-1	NUT, LOCK, HEX, TORQUE (M4)	53	
-	2	2	2-18032-2	SCR, SET, FLT POINT M3 X 10.0	52	
-	1	1	1-1976055-4	STANDOFF, HOLD-DOWN	50	
-	1	1	1-18030-0	NUT, HEX, REG M3.5	47	
-	1	1	1752320-1	EF SYSTEM III APPLICATOR	46	
-	1	1	1752308-1	RAM	44	
-	1	1	2-1655785-3	SCR, BTN SKT HD CAP (M8 X 25)	41	
-	1	1	993002-4	SCREW, SET, SFT TIP	40	
-	1	1	1962043-1	PLUNGER, BALL, METRIC	39	
-	1	1	1752309-3	RING, INSULATION CRIMP	38	
-	2	2	18028-2	WASHER, FLAT, REG M4	33	
-	6	6	18026-2	WASHER, SPRG LOCK, REG M4	32	
-	2	2	2-1655316-6	SCR, SKT HD CAP, M4 X 20.0	31	
-	2	2	1655785-2	SCR, BTN SKT HD CAP (M4 X 12)	29	
-	1	1	1-690451-8	SPACER, STRIPPER	28	
-	1	1	240639-1	STRIPPER (MACHINING)	27	
-	2	2	1320906-1	STUD, THREADED	25	
-	1	1	1752371-5	PLATE, STRIP GUIDE	24	
-	2	2	22281-7	SPRING, DRAG	22	
-	1	1	1752373-1	DRAG	20	
-	2	2	1901259-7	GUIDE, LOWER STRIP	18	
-	4	4	1655785-5	SCR, BTN SKT HD CAP (M6 X 12)	17	
-	1	1	4-240641-0	SPACER	14	
⚠	-	1	1752360-1	SPACER, HOLD-DOWN	13	
-	1	1	240644-9	PLATE, REAR SHEAR	11	
⚠	-	1	690482-6	PLATE, FRONT SHEAR	9	
⚠	1	2	1-1333221-7	ANVIL, COMBINATION	8	
-	1	1	690474-8	BLADE, SLUG	7	
⚠	-	1	1901681-5	HOLDDOWN, TERMINAL	6	
-	1	1	240641-2	SPACER	5	
-	1	1	238009-1	BLOCK, FL CRIMPER SPACER	4	
⚠	1	2	2-456135-9	CRIMPER, INSULATION O PREMIUM	3	
-	1	1	1-455888-7	SPACER, CRIMPER	2	
⚠	1	2	1	456410-4	CRIMPER, WIRE PREMIUM	1

DIMENSIONS: mm [INCHES]		TOLERANCES UNLESS OTHERWISE SPECIFIED:		OWN B. HIGMAN 19NOV2007		Tyco Electronics Harrisburg, PA 17105-3608	
0 PLC	±	1 PLC	±0.1	APVD	T. ELGIN 19NOV2007	NAME END FEED SYSTEM III APPLICATOR	
2 PLC	±0.02	3 PLC	±0.005	PRODUCT SPEC		SIZE CAGE CODE DRAWING NO	
4 PLC	±0.0005	ANGLES	±0.0005	APPLICATION SPEC		RESTRICTED TO	
MATERIAL		FINISH		WEIGHT		A 00779 1911167	
CUSTOMER DRAWING				SCALE 3:5		SHEET 1 OF 1 REV A	