

Aluminum Stand Kit for Laser Rangefinders (#725-28920), fits Lightware SF10, SF11, and SF30

This precision-machined bracket mounts your Lightware SF10, SF11, and SF30 series laser rangefinder to your project. The stand is made from high-grade aluminum and it conveniently positions and protects the laser rangefinder in both stationary and mobile applications. Assembly is quick and easy.



Kit Contents



Assembled View

Features

- Fits Lightware #SF10 series of laser rangefinders
 - SF10-A – 25m (#28051)
 - SF10-B – 50m (#28052)
 - SF10-C – 100m (#28053)
- Custom CNC-machined in Rocklin, CA USA from 6061 high-grade aluminum
- Hardware for mounting the sensor to the stand and then attaching the stand to your project is included
- Dimensions (without sensor): 2.52 x 2.57 x 0.35 in (63.86 x 65.36 x 8.84 mm)

Kit Contents

- (1) SF10 Laser Aluminum Stand (#720-28006)
- (2) Screw, #4-40 x 1/4" Socket Head (#710-00047)
- (2) Screw, #6-32 x 1/2" Socket Head (#710-00033)
- (1) 3/32" Hex Key (#725-00025)

Note: kits made after May 1st 2018 no longer included the 7/64" Ball End Hex Key, available separately from Parallax if you don't already have one, #725-00021.

Tools Required (not included)

- A 7/64" Ball-end Hex Key, if using the included Two #6-32 x 1/2" Socket Head machine screws to attach the stand to your project.

Assembly Instructions

Step 1: Place the stand on a clean, smooth, flat surface with the two blind tapped holes facing up.

Step 2: Insert the SF10/11/30 laser rangefinder (as shown below) into the figure-8 shaped opening. Secure with two #4-40 x 1/4" long, socket-head screws using the 3/32" hex key. Do not overtighten.

Step 3: Mount the sensor to your project with two 6-32 x 1/2" socket-head screws using a ball-end 7/64" hex key (not included, available separately from Parallax if you don't have one, #725-00021).

Dimensional /Assembly Drawing

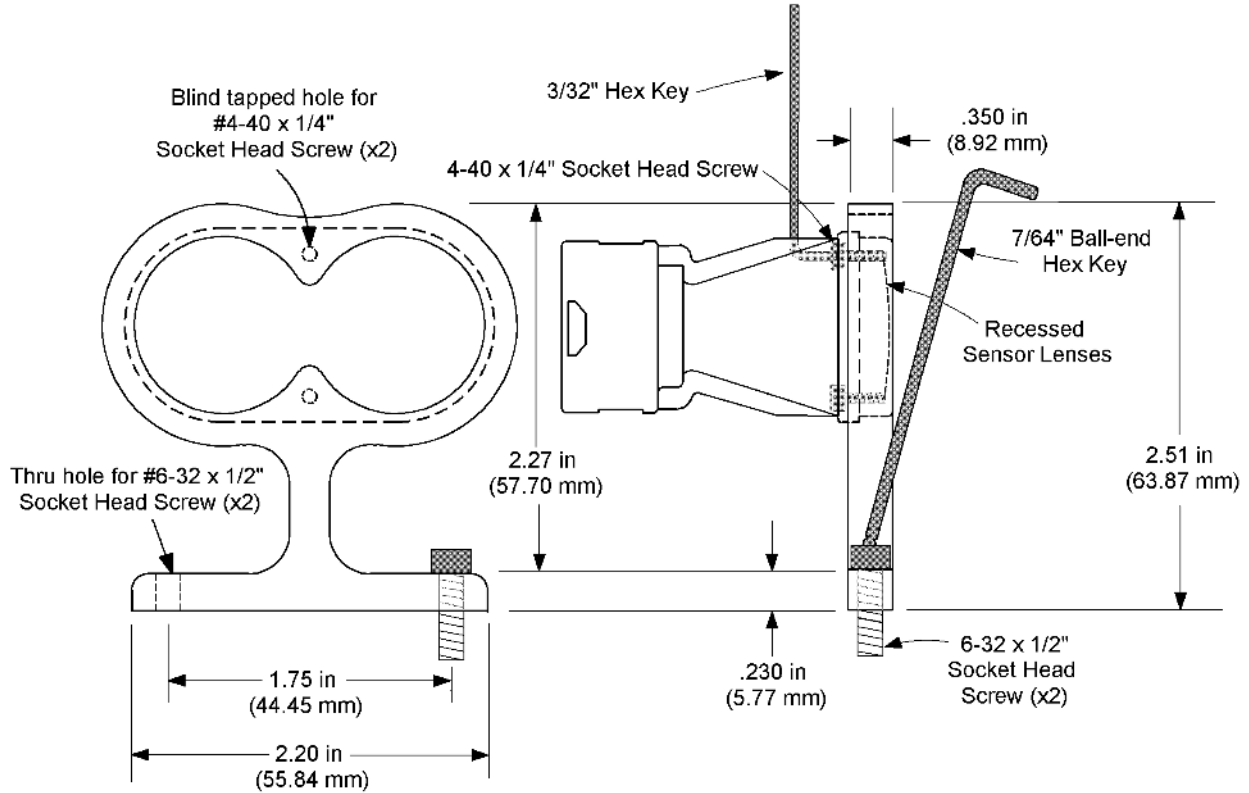

Revision History

Version 2.0: List of compatible Lightware Laser Rangefinder models updated. Updated to reflect removal of the 7/64" Ball End Hex Key from the kit (available separately from Parallax if you don't have one, #725-00021).