

LOC		DIST		REVISIONS			
AA	00	P	LTR	DESCRIPTION	DATE	DWN	APVD
		B		ECO-07-017784	15AUG2007	LAM	PR

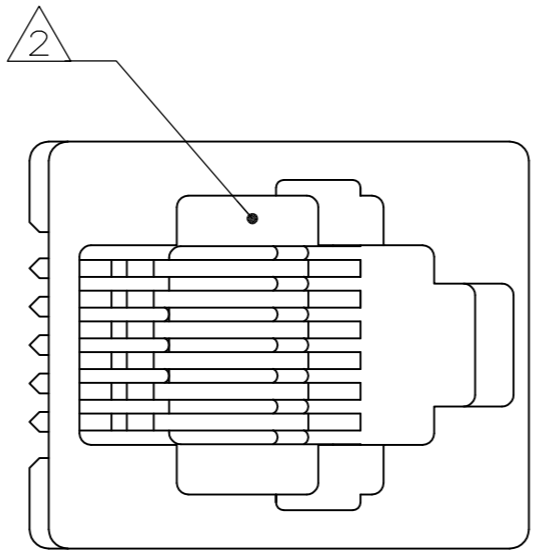

- MATERIAL: HOUSING - HTN MOLDING COMPOUND, UL 94V-0, COLOR: BLACK
 TERMINAL - 0.36[.014] THICK PHOS BRONZE PLATED WITH 1.27μm [.000050] MINIMUM THICK HARD GOLD IN LOCALIZED GOLD PLATE AREA AND 3.81μm [.000150] MINIMUM THICK MATTE TIN IN SOLDER AREA OVER 1.27μm [.000050] MINIMUM THICK NICKEL UNDERPLATE.

- △ CAVITY CONFORMS TO FCC RULES AND REGULATIONS PART 68, SUBPART F.
- △ BULK PACKAGED IN A TRAY.
- △ TERMINALS LOADED IN MIDDLE TWO (2) POSITIONS.

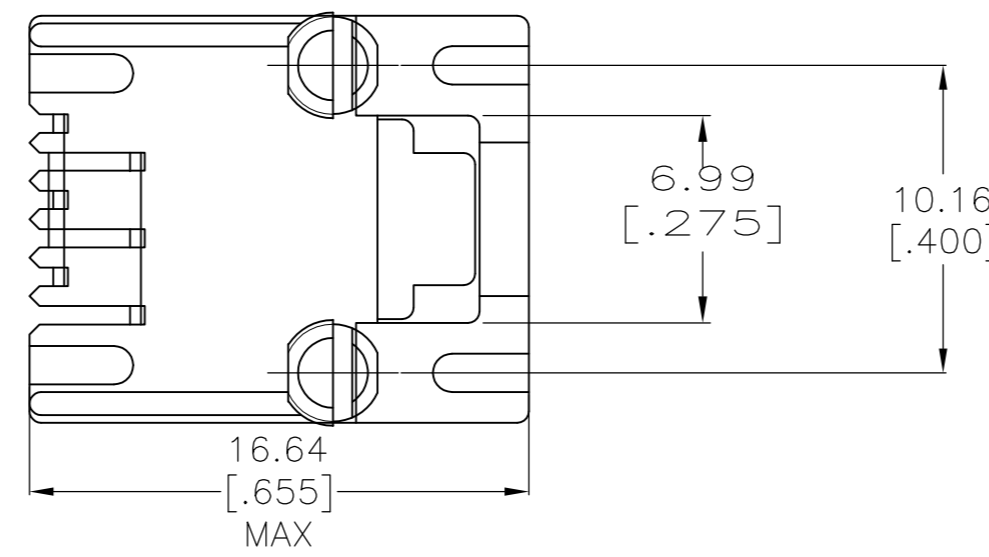
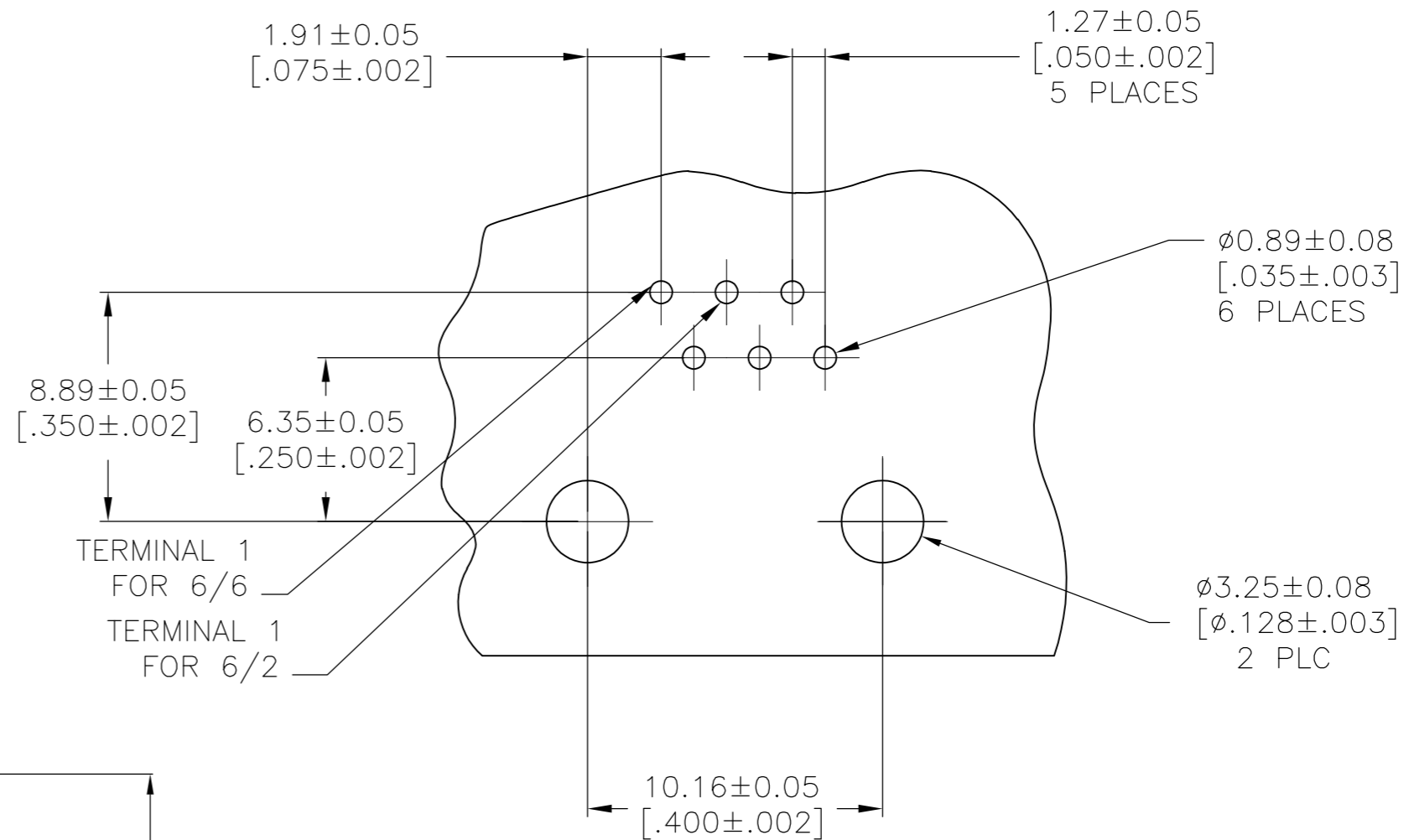
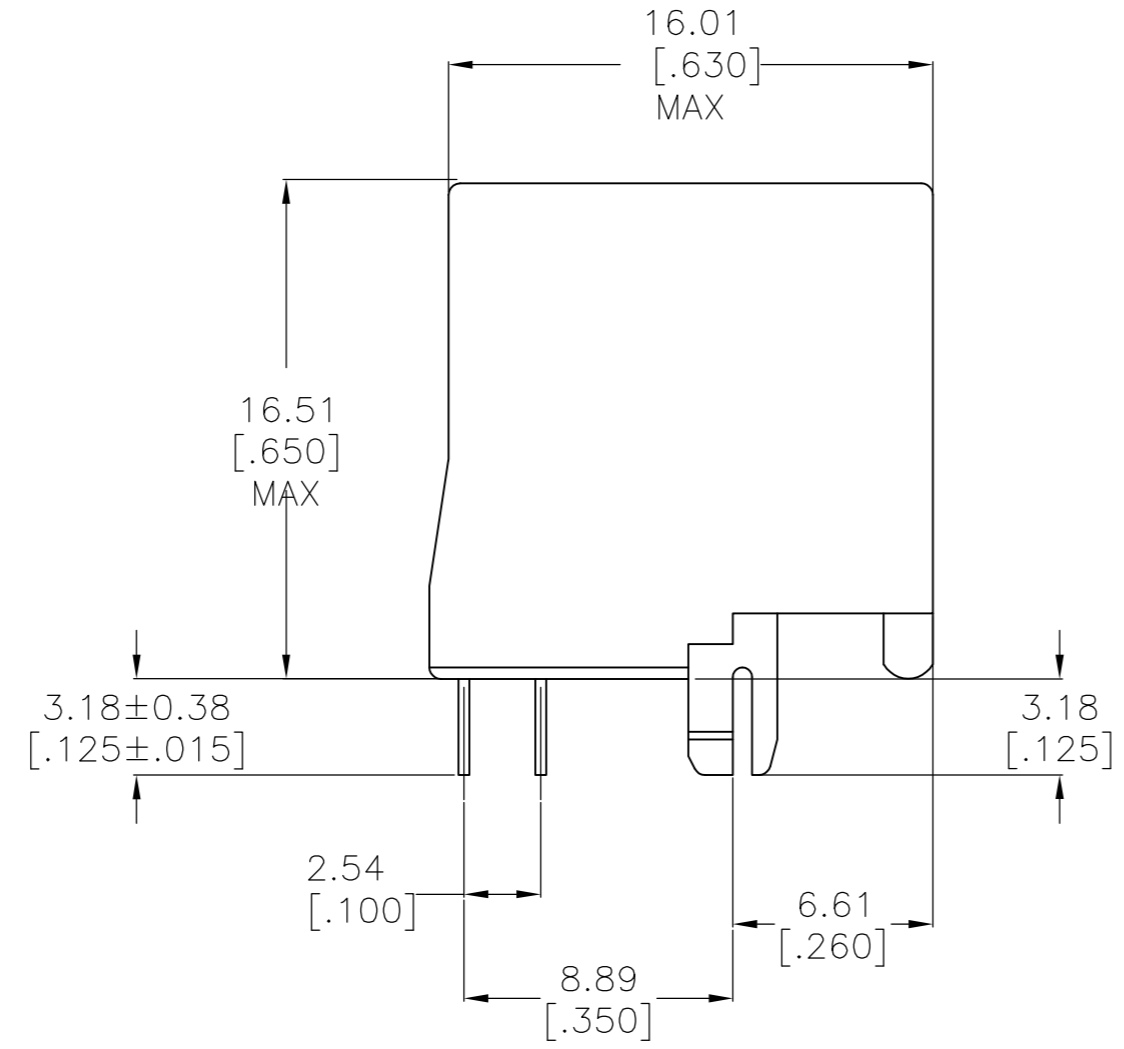
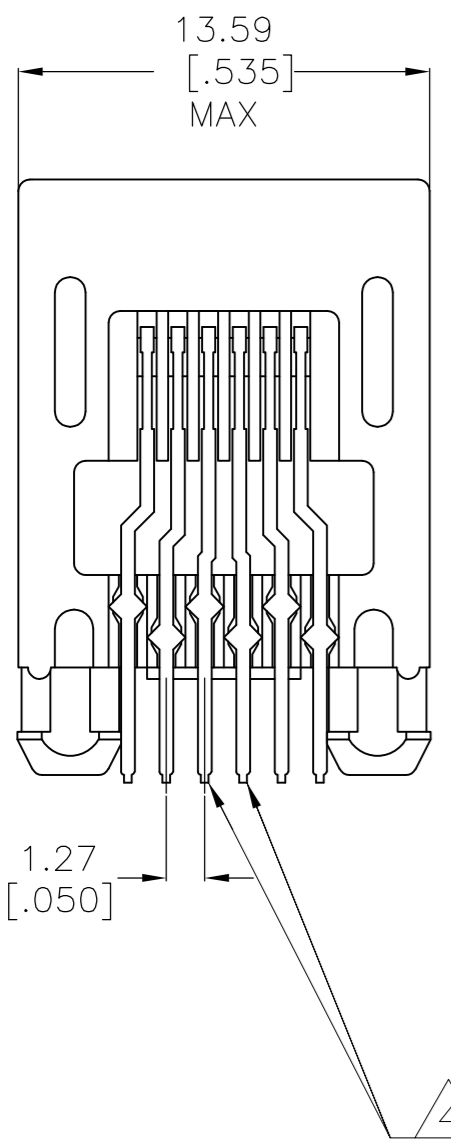

2	△ 4	△ 3	5569984-2
6		△ 3	5569984-1
TERMINALS		PACKAGED	PART NUMBER

THIS DRAWING IS A CONTROLLED DOCUMENT.		DWN L. VARELA - DOCK5 08JUN2005	Tyco Electronics Corporation Harrisburg, Pa 17105-3608	
DIMENSIONS: mm [INCHES]		CHK J. WESTMAN 08JUN2005	NAME	
TOLERANCES UNLESS OTHERWISE SPECIFIED:		APVD S. FLICKINGER 08JUN2005	PRODUCT SPEC	
0 PLC ± -		108-1163		MODULAR JACK ASSEMBLY, TOP ENTRY, 6 POSITION, WITHOUT PANEL STOPS
1 PLC ± -		APPLICATION SPEC		
2 PLC ± 0.13[.005]		114-2048		SIZE A2
3 PLC ± -		WEIGHT -		CAGE CODE 00779
4 PLC ± -		CUSTOMER DRAWING		DRAWING NO C=5569984
ANGLES ± -		SCALE 4:1		SHEET 1 OF 1
FINISH SEE NOTE 1		REV B		