

Features

- Floating gate driver designed for bootstrap operation
- Fully operational to +600 V
- Excellent dv/dt immunity
- Excellent negative V_S transient immunity
- Wide V_{CC} range
- UVLO on low-side and high-side
- Schmitt-trigger input with internal pull-down
- Output in phase with input
- Excellent latch immunity on all inputs & outputs
- RoHS compliant
- 6-pin SOT-23 package

Description

The IRS25752 is a high-side, single-channel gate driver IC with 600V blocking and level-shifting capability. This allows for the gate driver to be connected directly to the gate of a high-side power MOSFET, while being controlled by the low-side, ground potential circuitry. The IRS25752 includes a wide V_{CC} supply range, UVLO protection, and excellent immunity to harsh dv/dt or $-V_S$ switching environments. IR's HVIC technology allows for these functions and features to be realized in a 6-pin SOT-23 package.

Applications

- High-side gate driver control
- Pulse transformer replacement
- General purpose switched mode power electronics

Package Options

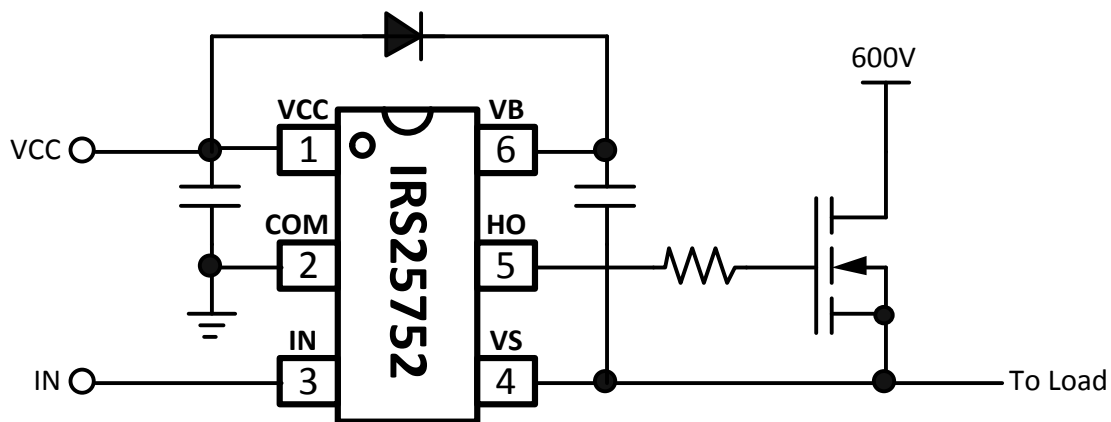
Typical Connection Diagram

Ordering Information

Base Part Number	Package Type	Standard Pack		Orderable Part Number
		Form	Quantity	
IRS25752LPBF	SOT-23-6L	Tape and Reel	3000	IRS25752LTRPBF

Table of Contents	Page
Description	1
Ordering Information	1
Typical Connection Diagram	1
Absolute Maximum Ratings	3
Recommended Operating Conditions	3
Electrical Characteristics	4
Functional Block Diagram	5
Timing Diagram	6
Lead Definitions	7
Lead Assignments	7
Package Details: 6L-SOT23	9
Tape and Reel Details: 6L-SOT23	10
Part Marking Information	12
Qualification Information	13

Absolute Maximum Ratings

Absolute maximum ratings indicate sustained limits beyond which damage to the device may occur. All voltage parameters are absolute voltages referenced to COM, all currents are defined positive into any pin. The thermal resistance and power dissipation ratings are measured under board mounted and still air conditions.

Symbol	Definition		Min	Max	Units
V_B	High side floating absolute voltage		-0.3	620	V
V_S	High side floating supply offset voltage		$V_B - 20$	$V_B + 0.3$	
V_{HO}	High side floating gate drive output voltage		$V_S - 0.3$	$V_B + 0.3$	
V_{CC}	Low side and logic fixed supply voltage		-0.3	20	
V_{IN}	Logic input voltage		COM - 0.3	$V_{CC} + 0.3$	
COM	Logic ground		$V_{CC} - 20$	$V_{CC} + 0.3$	
dVS/dt	High side floating supply offset voltage slew rate		---	50	V/ns
RO_{JA}	Thermal resistance, junction to ambient	6L-SOT-23	---	151	°C/W
T_J	Junction temperature		-55	150	°C
T_S	Storage temperature				
T_L	IC Pin temperature (soldering, 10 seconds)				
			---	300	

Recommended Operating Conditions

For proper operation the device should be used within the recommended conditions.

Symbol	Definition	Min	Max	Units
V_B	High side floating absolute voltage	$V_S + 10$	$V_S + 18$	V
V_S	High side floating supply offset voltage	COM - 8 [†]	600	
V_{HO}	High side floating gate drive output voltage	V_S	V_B	
V_{CC}	Low side and logic fixed supply voltage	10	18	
V_{IN}	Logic input voltage	COM	V_{CC}	
T_J	Junction temperature	-40	125	°C

† Logic operational for V_S of -8V to +600V. Logic state held for V_S of -8V to $-V_{BS}$.

Electrical Characteristics
 $V_{CC}=15V$, $V_{BS}=15V$, $C_L=1000pF$, and $T_A = 25\text{ }^\circ\text{C}$ unless otherwise specified.

Symbol	Definition	Min	Typ	Max	Units	Test Conditions	
Low Side Characteristics							
V_{CCUV+}	V_{CC} supply UVLO positive-going	8.0	9.0	10.0	V		
V_{CCUV-}	V_{CC} supply UVLO negative-going	7.0	8.0	9.0			
I_{QCC}	Quiescent V_{CC} supply current	---	100	---	μA		
V_{CC_CLAMP}	V_{CC} internal Zener clamp voltage	---	20.4	---	V	$I_{CC} = 5\text{mA}$	
V_{IH}	Logic "1" input voltage	---	---	2.2			
V_{IL}	Logic "0" input voltage	0.8	---	---			
I_{IN+}	Logic "1" input bias current	---	20	40	μA	$V_{IN} = V_{CC}$	
I_{IN-}	Logic "0" input bias current	---	---	5		$V_{IN} = \text{COM}$	
High Side Characteristics							
V_{BSUV+}	V_{BS} supply UVLO positive-going	8.0	9.0	10.0	V		
V_{BSUV-}	V_{BS} supply UVLO negative-going	7.0	8.0	9.0			
V_{BS_CLAMP}	V_{BS} internal Zener clamp voltage	---	20.4	---			$I_{BS} = 5\text{mA}$
V_{OH}	High level output voltage ($V_B - HO$)	---	0.8	1.4			$I_O = 2\text{mA}$
V_{OL}	Low level output voltage ($HO - V_S$)	---	0.3	0.6			
I_{LK}	Offset supply leakage current	---	---	50	μA	$V_B = V_S = 600\text{V}$	
I_{QBS}	Quiescent V_{BS} supply current	---	80	---		$V_{IN} = V_{CC}$ or COM	
Gate Drive Characteristics							
t_{ON}	Turn-on propagation delay	---	140	---	ns	$V_S = 0\text{V}$	
t_{OFF}	Turn-off propagation delay	---	215	---		$V_S = 600\text{V}$	
t_{RISE}	Turn-on rise time	---	85	---		$V_S = 0\text{V}$	
t_{FALL}	Turn-off fall time	---	40	---			
I_{O+}	HO gate drive output source current	---	160	---	mA		
I_{O-}	HO gate drive output sink current	---	240	---			

Functional Block Diagram

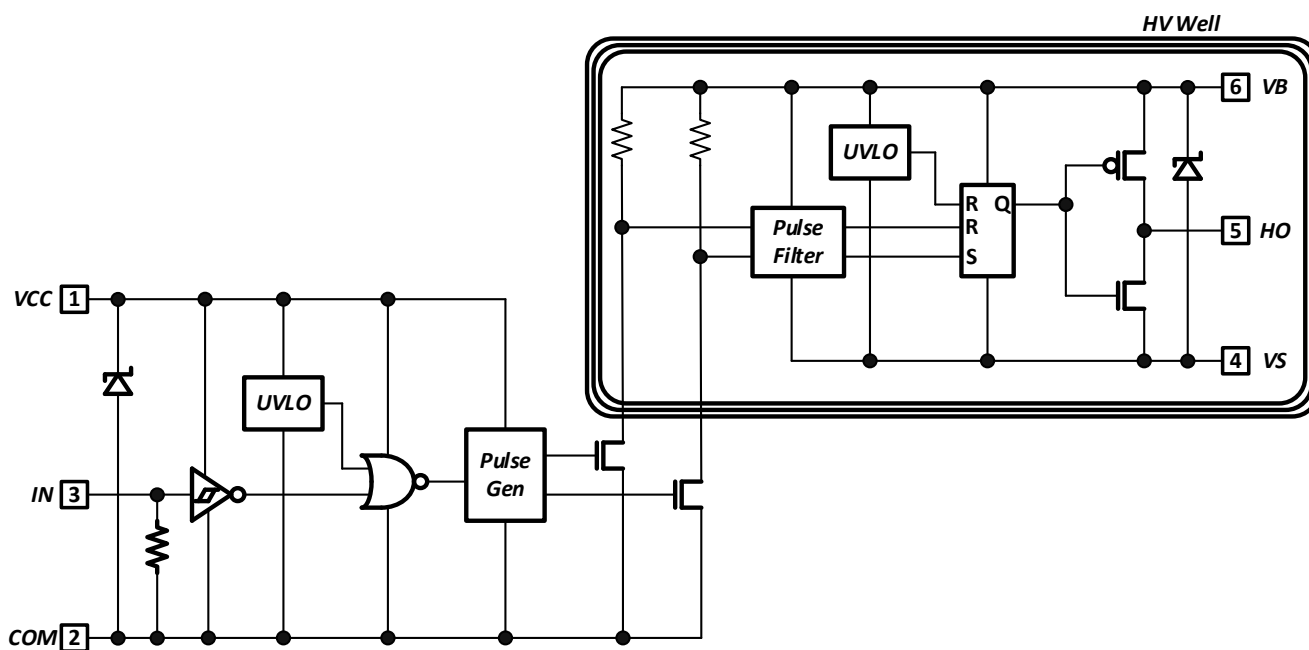

Timing Diagram

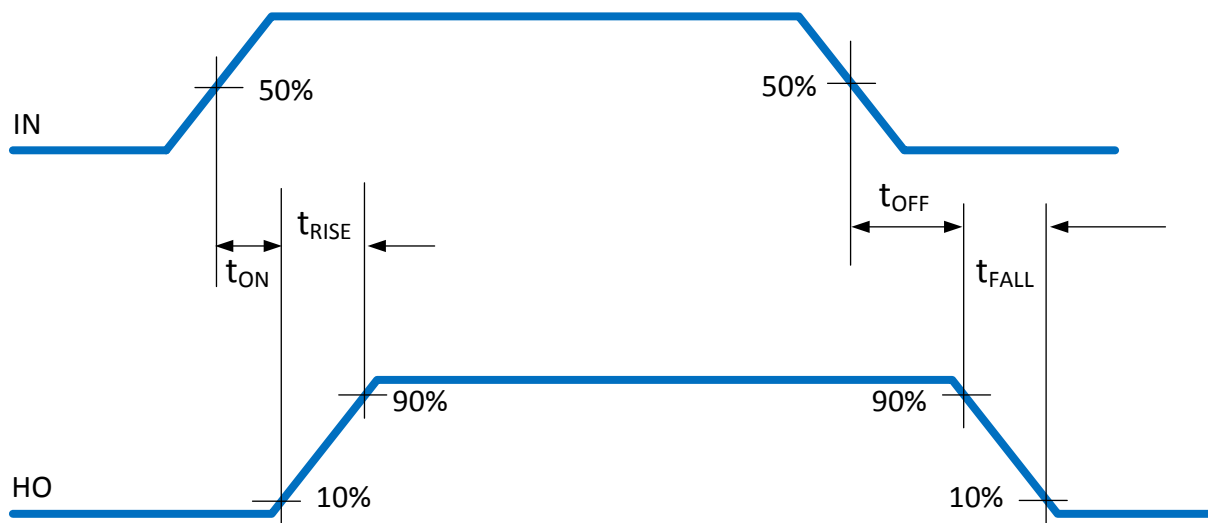

Pin Definitions

Pin	Symbol	Description
1	VCC	IC supply voltage
2	COM	IC power and signal ground
3	IN	Logic input
4	VS	High side floating supply offset voltage
5	HO	High side gate driver output
6	VB	High side floating supply voltage

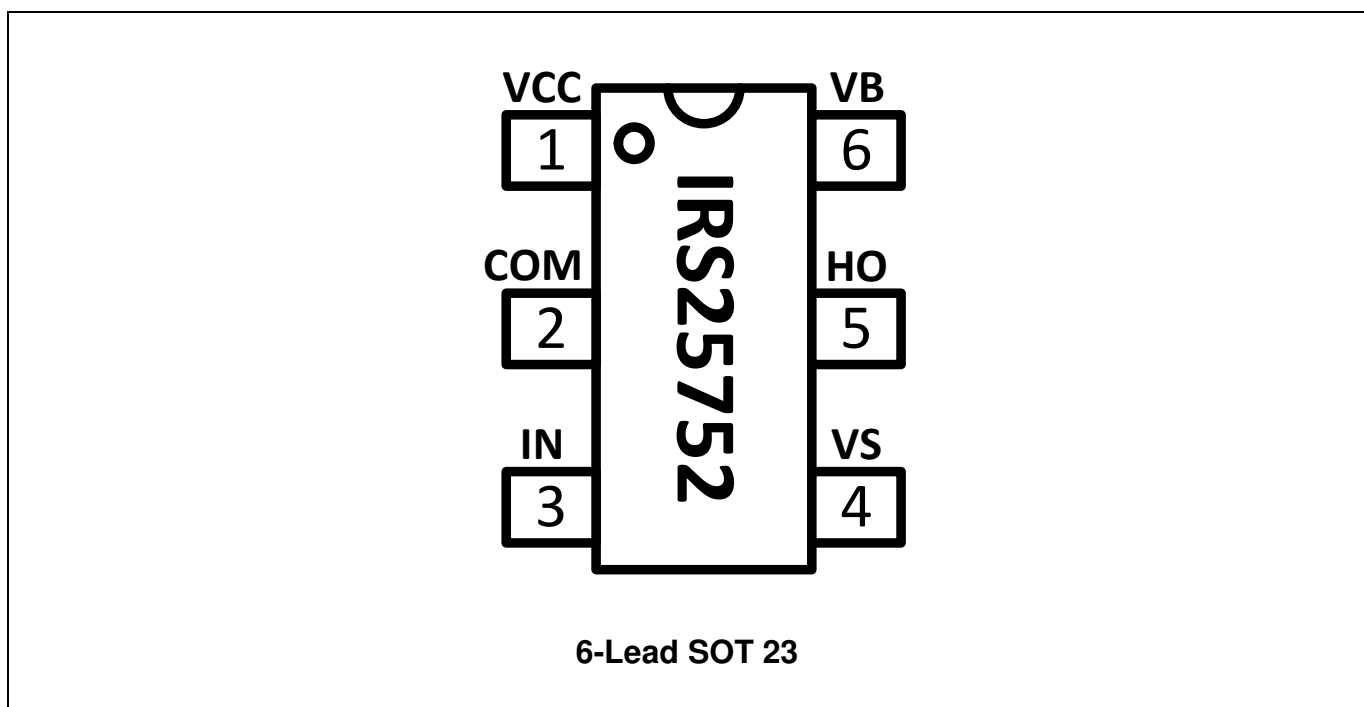
Pin Assignments

Package Details: 6L-SOT23

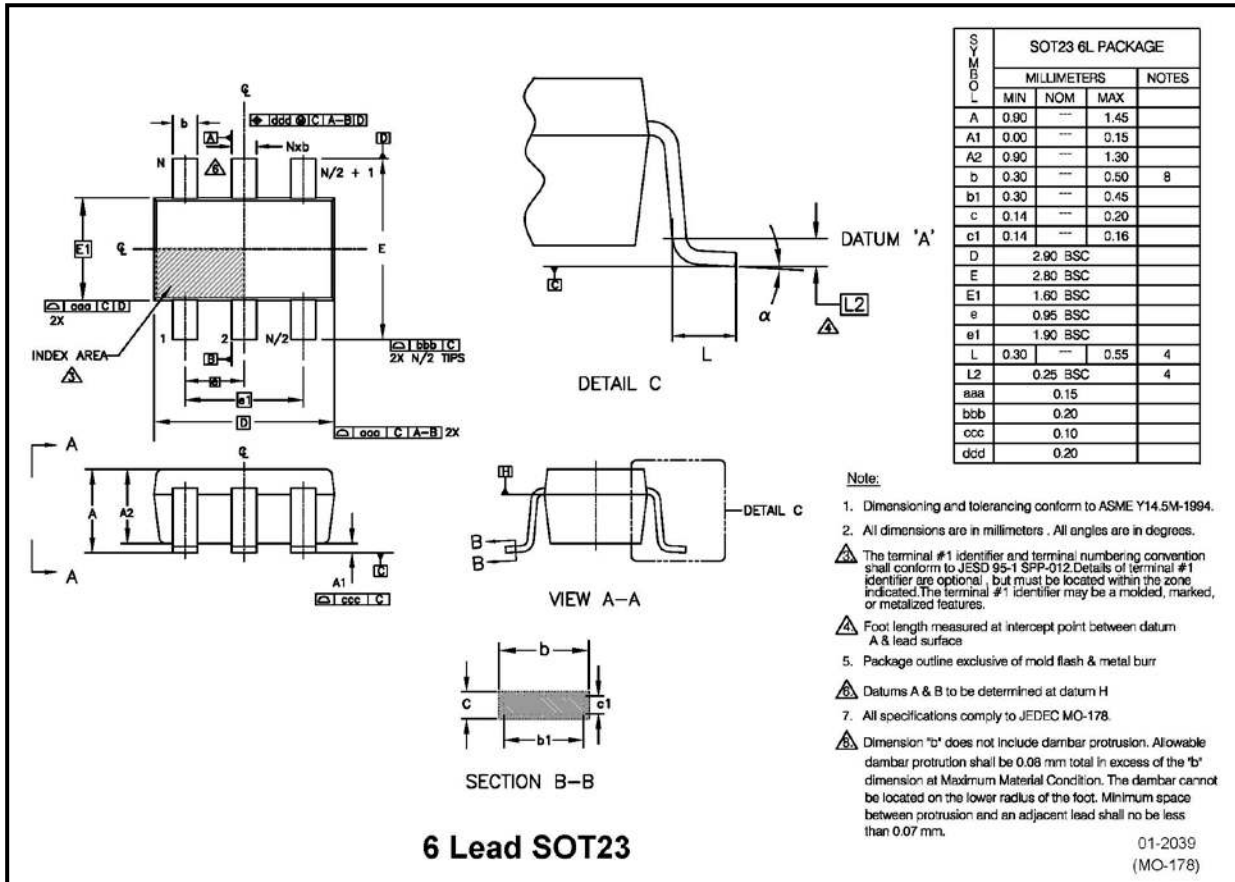

Tape and Reel Details: 6L-SOT23

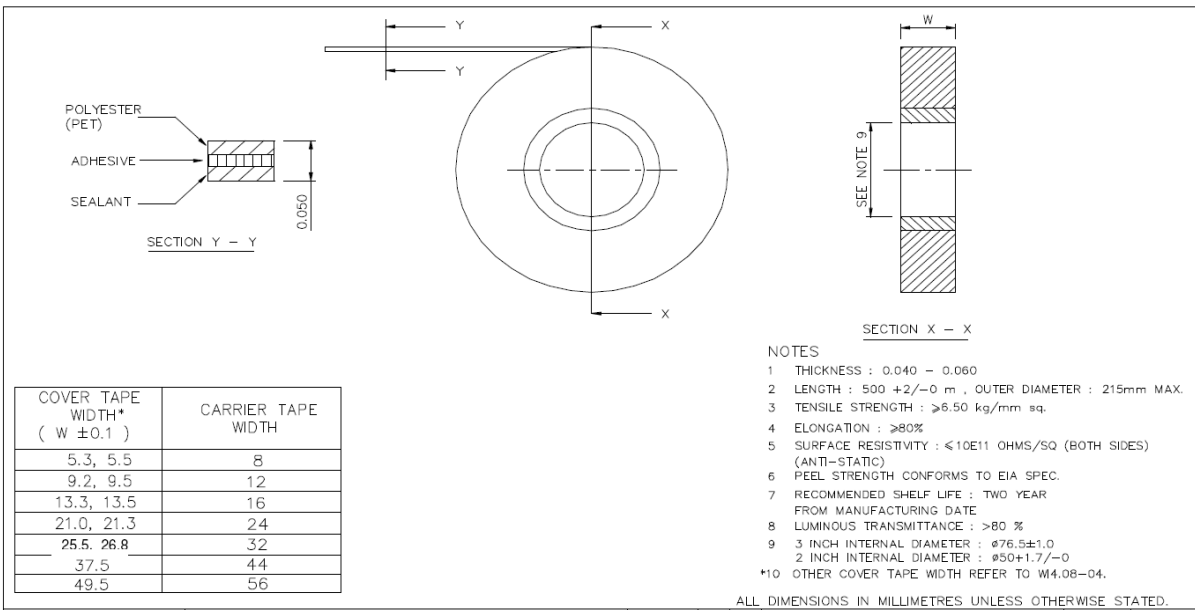
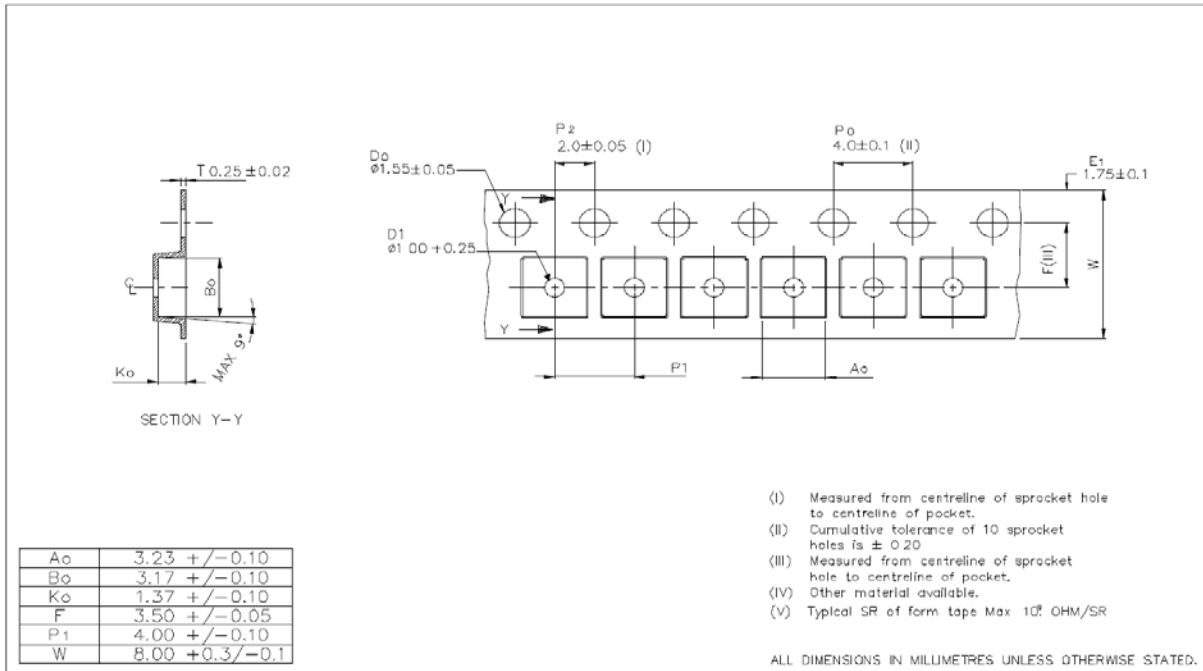

Tape and Reel Details: 6L-SOT23

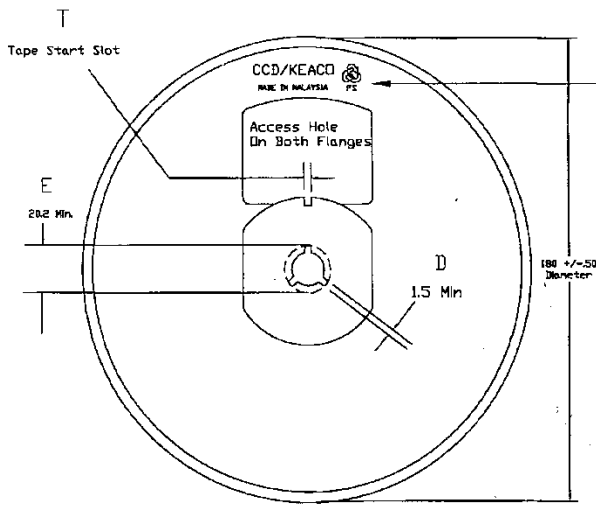

FRONT VIEW

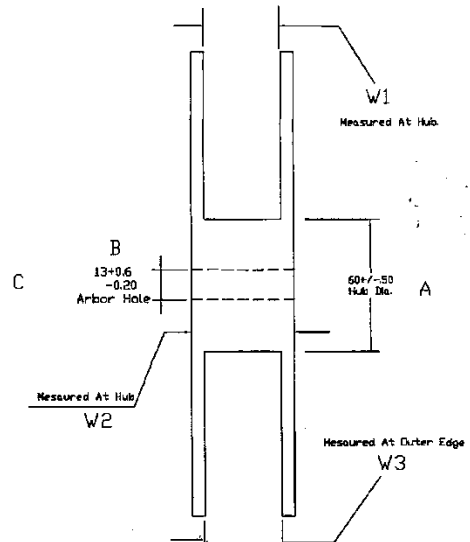

SIDE VIEW

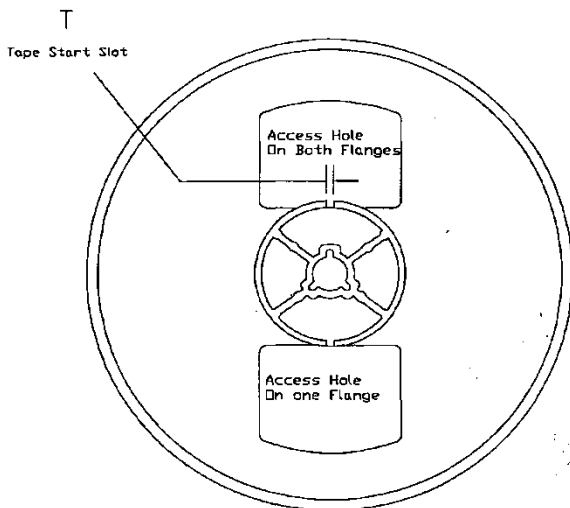

BACK VIEW

- NOTE:**
1. MATERIAL : POLYSTRENE
 2. SURFACE RESISTIVITY : $\leq 10E11$ OHMS/SQ (EXTERNAL OR DIPPED)
 3. STATIC DECAY : < 2 SEC. AT 50%RH

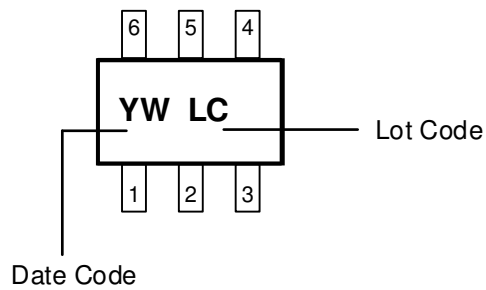
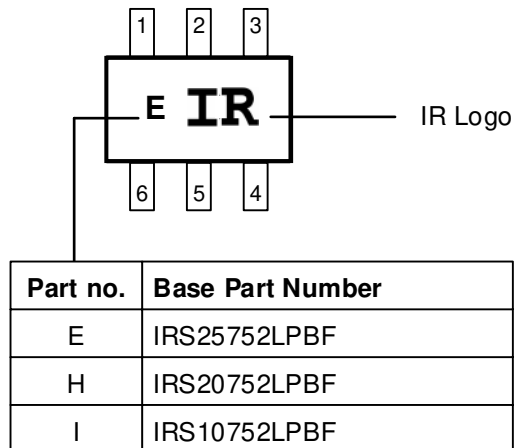
Part Marking Information: 6 Lead SOT23
Top Marking

Bottom Marking

Qualification Information[†]

Qualification Level		Industrial ^{††} (per JEDEC JESD 47E)	
		Comments: This family of ICs has passed JEDEC's Industrial qualification. IR's Consumer qualification level is granted by extension of the higher Industrial level.	
Moisture Sensitivity Level		SOT-23	MSL1 ^{†††} (per IPC/JEDEC J-STD-020C)
ESD	Machine Model	Class B (per JEDEC standard EIA/JESD22-A115-A)	
	Human Body Model	Class 1B (per EIA/JEDEC standard JESD22-A114-B)	
IC Latch-Up Test		Class I, Level A (per JESD78A)	
RoHS Compliant		Yes	

† Qualification standards can be found at International Rectifier's web site <http://www.infineon.com/>

†† Higher qualification ratings may be available should the user have such requirements. Please contact your International Rectifier sales representative for further information.

††† Higher MSL ratings may be available for the specific package types listed here. Please contact your International Rectifier sales representative for further information.

Revision History

Date	Comment
01/04/2017	<ul style="list-style-type: none"> • Updated "Infineon" logo –all pages • Added disclaimer on last page. • Updated part marking information on page 11.

Published by
Infineon Technologies AG
81726 Munich, Germany
© Infineon Technologies AG 2016
All Rights Reserved.

IMPORTANT NOTICE

The information given in this document shall in no event be regarded as a guarantee of conditions or characteristics ("Beschaffenhheitsgarantie"). With respect to any examples, hints or any typical values stated herein and/or any information regarding the application of the product, Infineon Technologies hereby disclaims any and all warranties and liabilities of any kind, including without limitation warranties of non-infringement of intellectual property rights of any third party.

In addition, any information given in this document is subject to customer's compliance with its obligations stated in this document and any applicable legal requirements, norms and standards concerning customer's products and any use of the product of Infineon Technologies in customer's applications.

The data contained in this document is exclusively intended for technically trained staff. It is the responsibility of customer's technical departments to evaluate the suitability of the product for the intended application and the completeness of the product information given in this document with respect to such application.

For further information on the product, technology, delivery terms and conditions and prices please contact your nearest Infineon Technologies office (www.infineon.com).

WARNINGS

Due to technical requirements products may contain dangerous substances. For information on the types in question please contact your nearest Infineon Technologies office.

Except as otherwise explicitly approved by Infineon Technologies in a written document signed by authorized representatives of Infineon Technologies, Infineon Technologies' products may not be used in any applications where a failure of the product or any consequences of the use thereof can reasonably be expected to result in personal injury.