

**RIGHT ANGLE PLUG CRIMP TYPE**

**CABLE 2.6/50 S**

**R223.182.000**

Series : MMBX

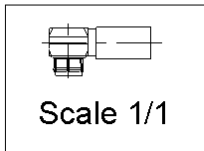
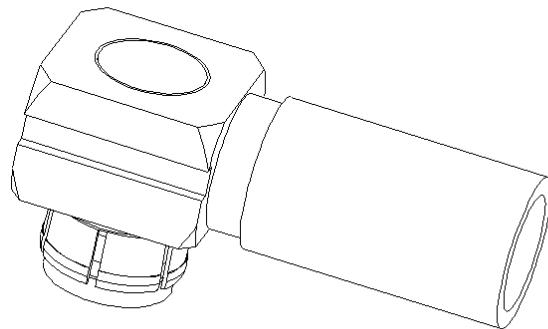
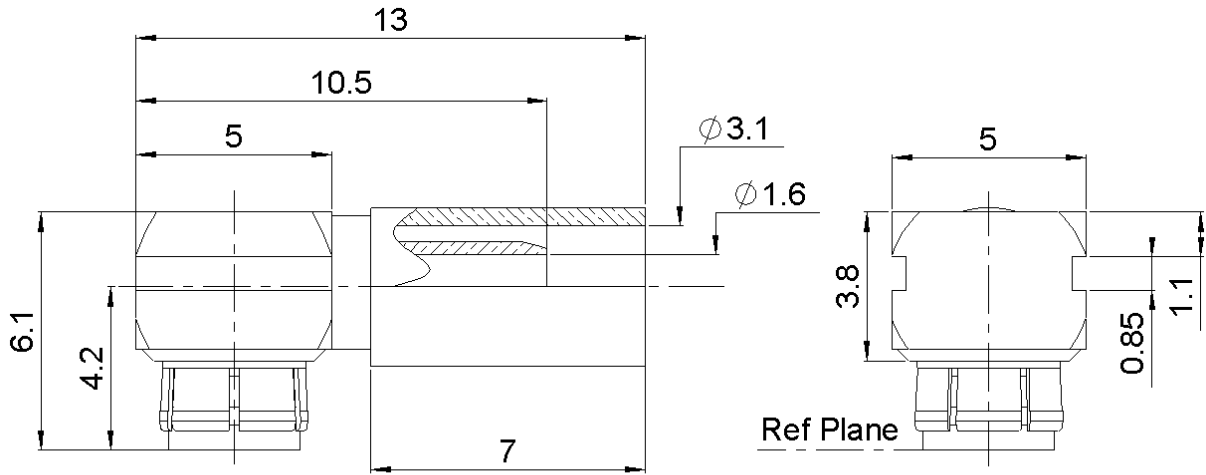

All dimensions are in mm.

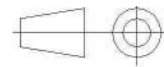

COMPONENTS	MATERIALS	PLATING (µm)
<b>BODY</b>	<b>BRASS</b>	<b>NPGR</b>
<b>CENTER CONTACT</b>	<b>BERYLLIUM COPPER</b>	<b>NPGR</b>
<b>OUTER CONTACT</b>	<b>BERYLLIUM COPPER</b>	<b>NPGR</b>
<b>INSULATOR</b>	<b>PTFE</b>	
<b>GASKET</b>		
<b>OTHERS PARTS</b>	<b>BRASS</b>	<b>NPGR</b>
-	-	-
-	-	-

Issue : 0735 B

In the effort to improve our products, we reserve the right to make changes judged to be necessary.



**RIGHT ANGLE PLUG CRIMP TYPE**

**R223.182.000**

**CABLE 2.6/50 S**

Series : MMBX

**PACKAGING**

Standard	Unit	Other
<b>100</b>	<b>'W' option</b>	<b>Contact us</b>

**SPECIFICATION**

**ELECTRICAL CHARACTERISTICS**

Impedance		<b>50</b> Ω
Frequency		<b>0-12.4</b> GHz
VSWR	<b>1.17 +</b>	<b>0,0000</b> x F(GHz) Maxi
Insertion loss		<b>0.18</b> √F(GHz) dB Maxi
RF leakage	- (	<b>100</b> - F(GHz)) dB Maxi
Voltage rating		<b>250</b> Veff Maxi
Dielectric withstanding voltage		<b>750</b> Veff mini
Insulation resistance		<b>1000</b> MΩ mini

**CABLE ASSEMBLY**

Stripping	a	b	c	d	e	f
mm	2,00	4,50	9,50	0,00	7,50	0,00

Assembly instruction :

Recommended cable(s)  
RG 316  
RG 188

Characteristics indicated on this data sheet are those that can be achieved with the highest performance cable. Intrinsic limitations of the cable may diminish the performance of the assembly

Cable retention

- pull off **90** N mini  
- torque **NA** N.cm

**MECHANICAL CHARACTERISTICS**

Center contact retention		
Axial force – Mating end	<b>10</b>	N mini
Axial force – Opposite end	<b>10</b>	N mini
Torque	<b>NA</b>	N.cm mini

**TOOLING**

Part Number	Description	Hexagon
.	.	.
R282.235.906	CRIMPING DIES	3.3
R282.293.000	CRIMPING TOOL M22520/5-01	
R282.868.000	EXTRACTION ASSEMBLY TOOL	

Recommended torque		
Mating	<b>NA</b>	N.cm
Panel nut	<b>NA</b>	N.cm
Clamp nut	<b>NA</b>	N.cm
A/F clamp nut	<b>0,0000</b>	mm

Mating life	<b>100</b>	Cycles mini
Weight	<b>1,0930</b>	g

**OTHER CHARACTERISTICS**

to 6 GHz  
Interface MMBX only up to 2.5GHz

**ENVIRONMENTAL**

Operating temperature	<b>-55/+155</b>	° C
Hermetic seal	<b>NA</b>	Atm.cm3/s
Panel leakage	<b>NA</b>	

Issue : 0735 B

In the effort to improve our products, we reserve the right to make changes judged to be necessary.



**RIGHT ANGLE PLUG CRIMP TYPE**

**R223.182.000**

**CABLE 2.6/50 S**

Series : MMBX

**COMPONENTS**

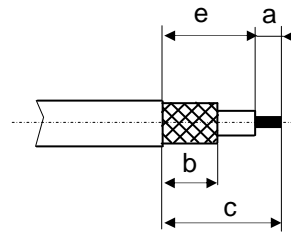
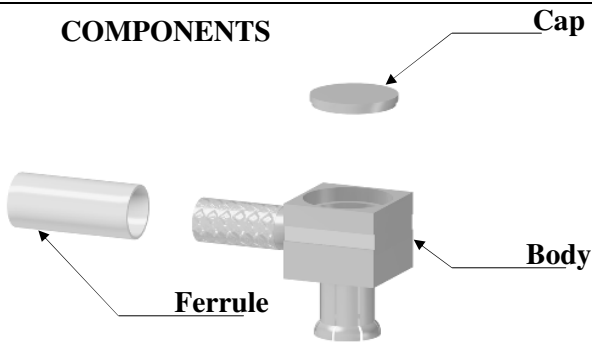

**1**

Slide the ferrule onto the cable.  
Strip the cable.  
Tin the cable inner conductor.

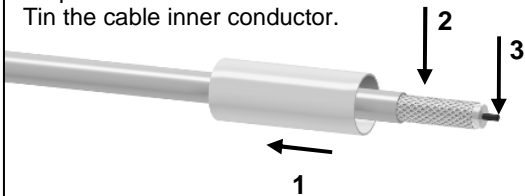

**4**

Crimp the ferrule with crimping tool ( see connector TDS ).  
Solder the inner conductor.

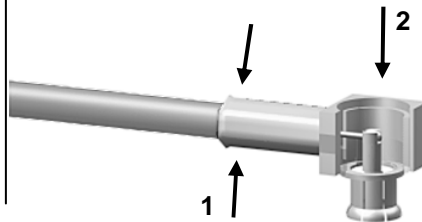

**2**

Fan the braid.



**5**

Place the insulator into the body.  
Place the cap into the body.

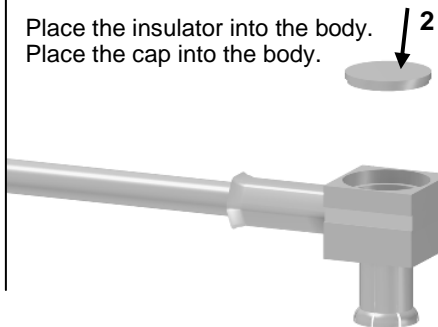

**3**

Push the connector body under the braid.  
Slide the ferrule over the braid.

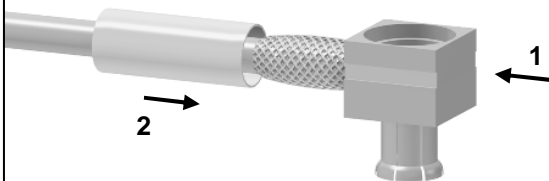

**6**

Slide mounting tool R282.868.000 onto the body grooves.  
Drive the cap into rear opening of body by rotating the handle of the mounting tool.

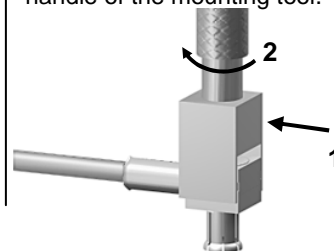

Issue : 0735 B

In the effort to improve our products, we reserve the right to make changes judged to be necessary.

