

DETAIL A

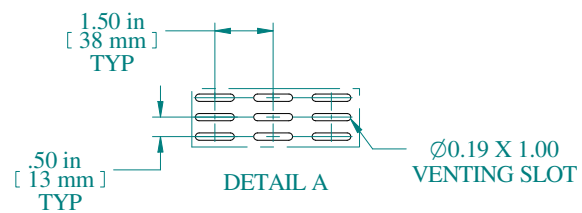
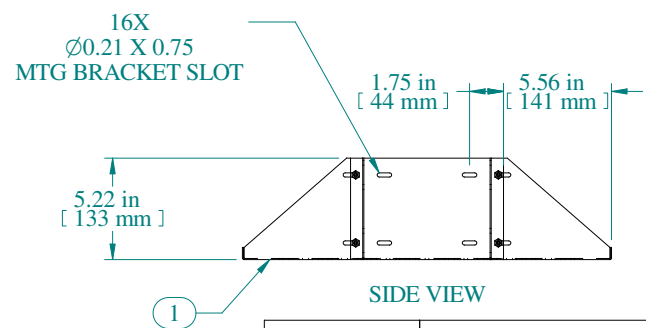
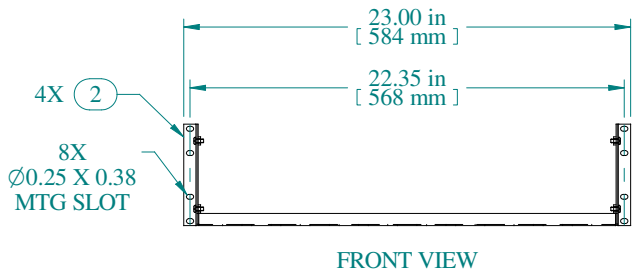

Item Number	Title	Quantity
1	DNRM - VENTED SHELF	1
2	DNRM - MTG BRACKET	4
3	SCREW 10-32 X 3/8	8
4	10-32 KEP NUT	8

PART NUMBERS	
DNRMV23BK1	PAINTED BLACK TEXTURED

NOTES
 Maximum Weight 275 lb
 Mounting Hardware Included for 10-32 & 12-24 Tapped Rails
 Some Assembly Required

Data subject to change without notice. Isometric drawing not to scale.

HAMMOND MANUFACTURING™
 www.hammondmfg.com
 PART NO. DNRMV23