

LOC		DIST		REVISIONS			
GP	00	REV	DATE	BY	CHK	APPV	
C		REVISED PER ECO-07-000077	14FEB07	CJV	SB		
C1		REVISED PER ECO-10-000443	18JAN10	KK	HMR		

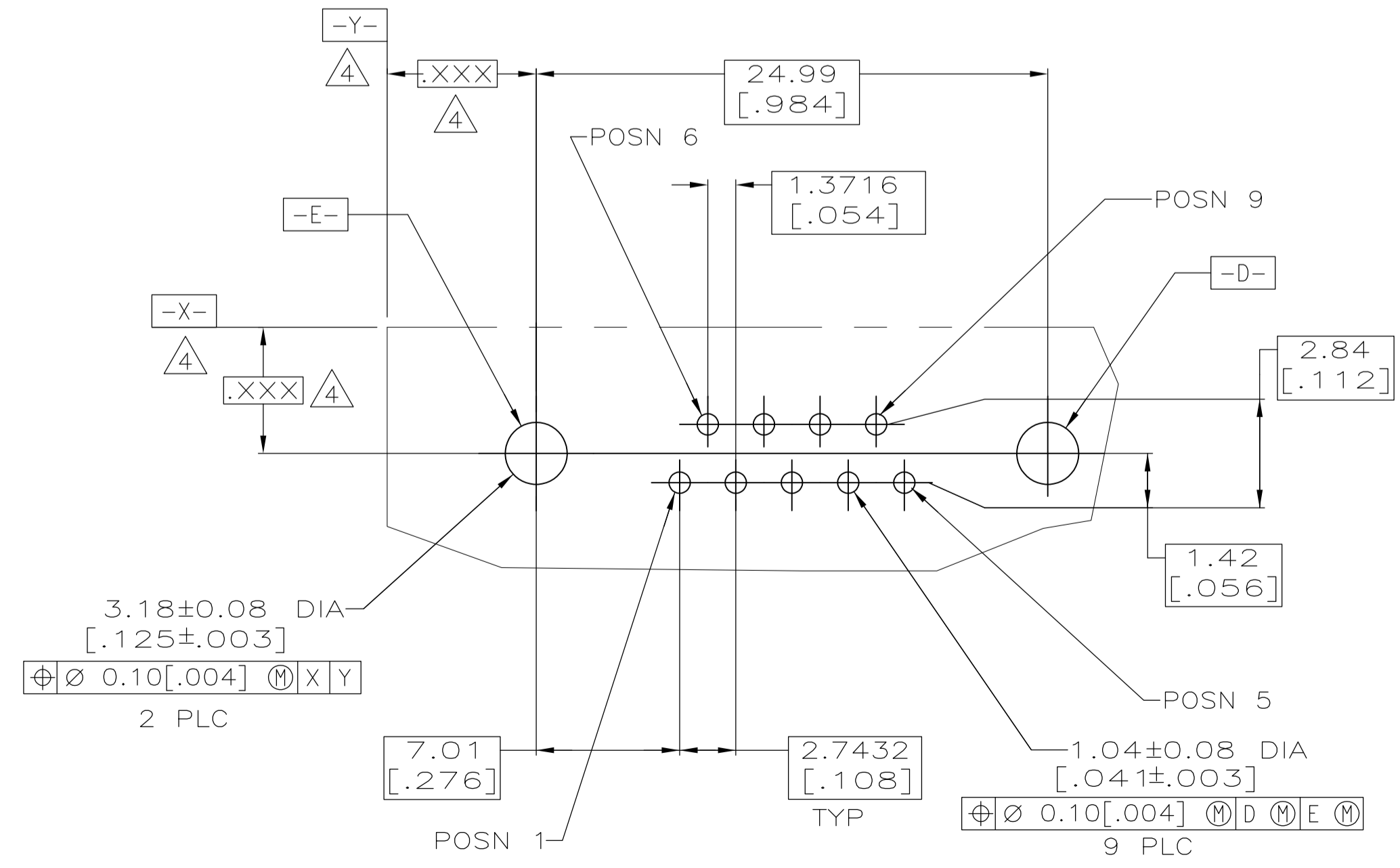
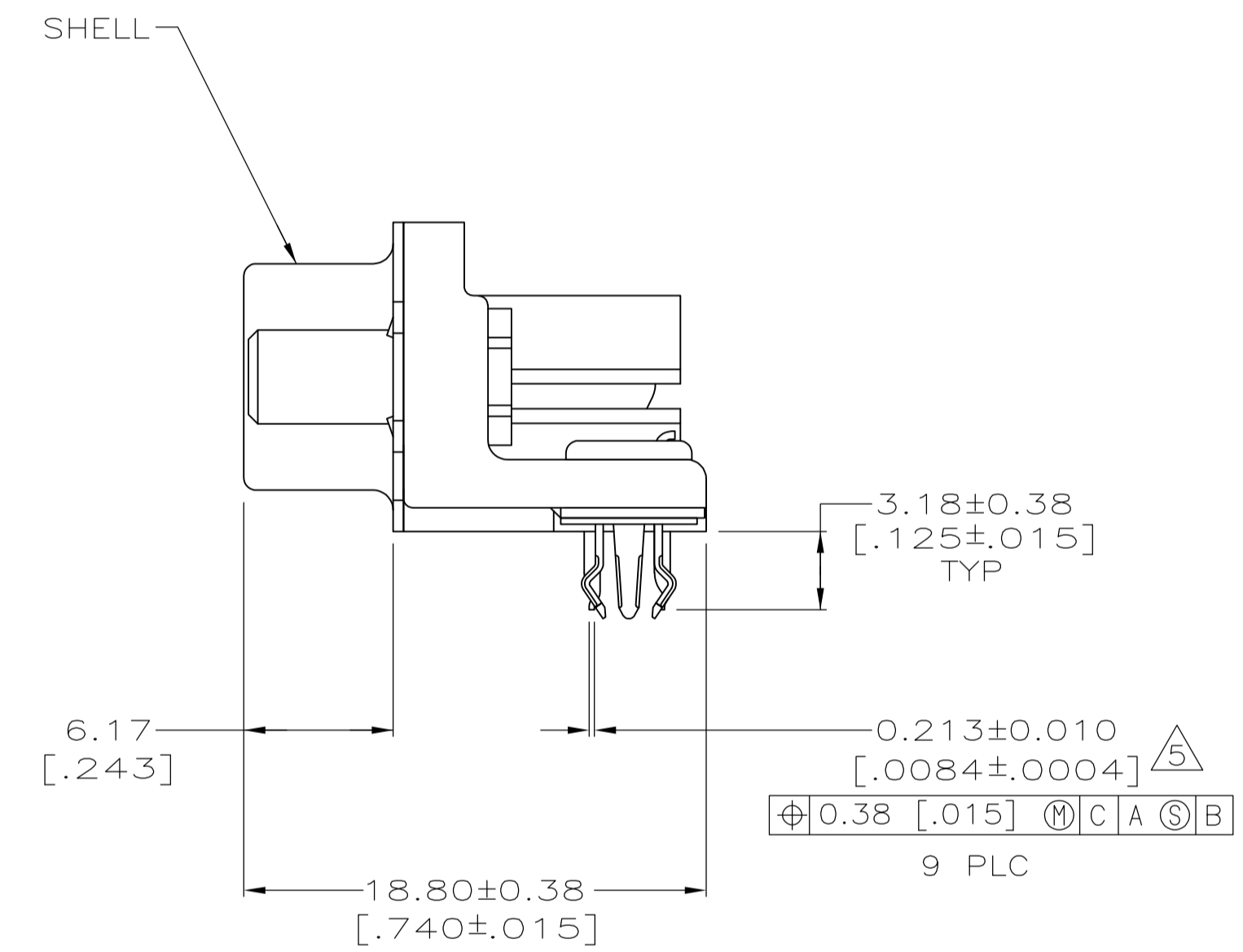
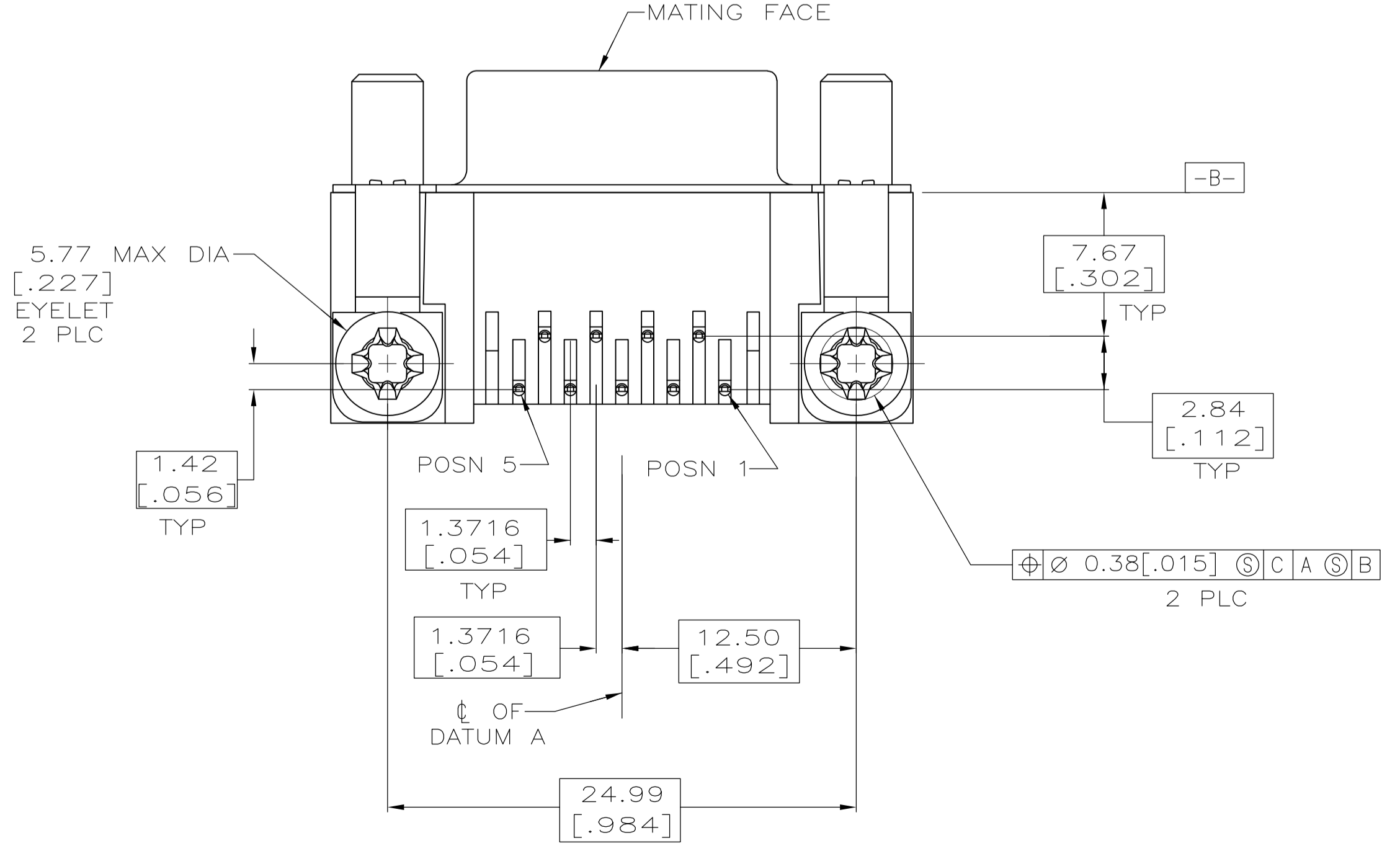
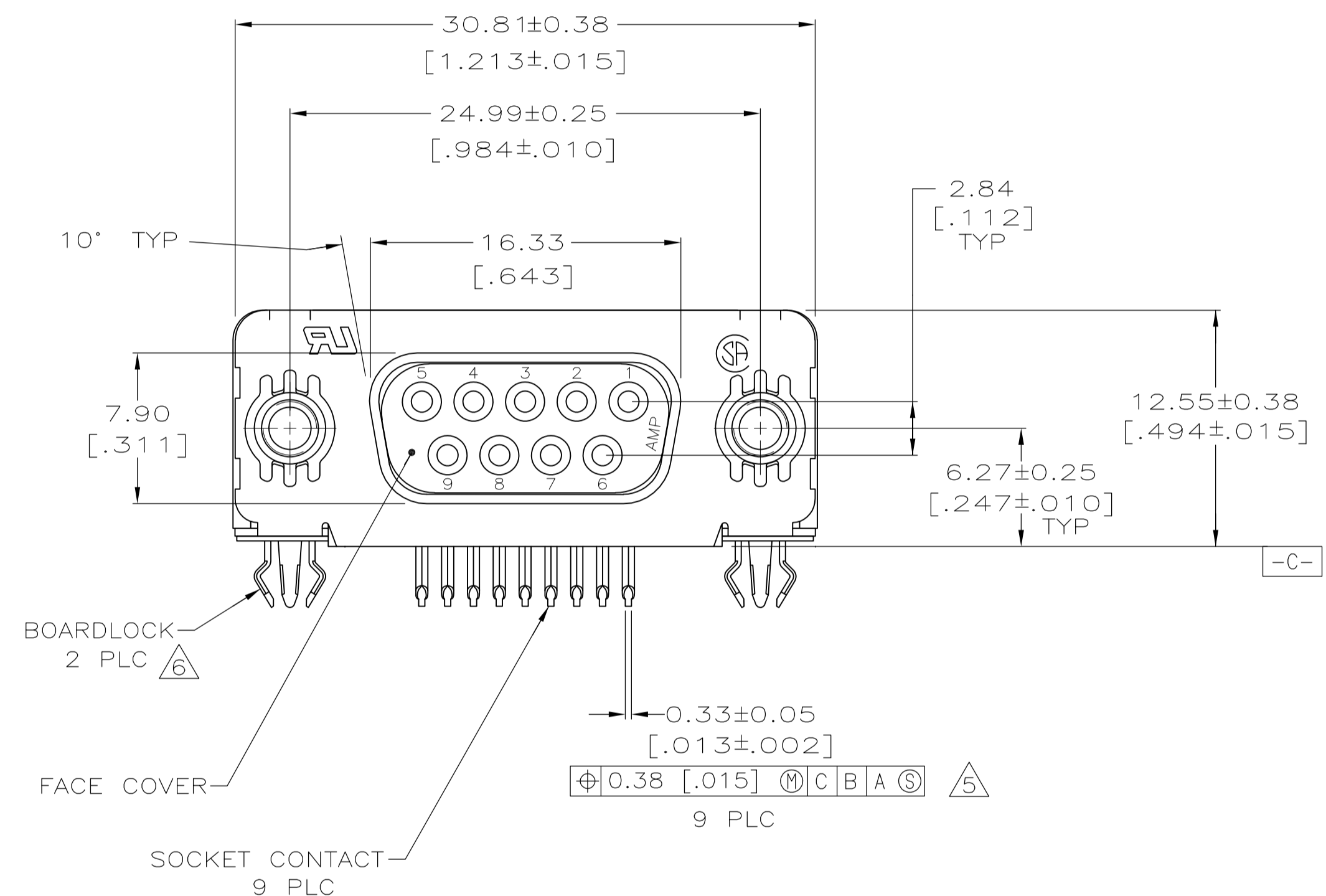
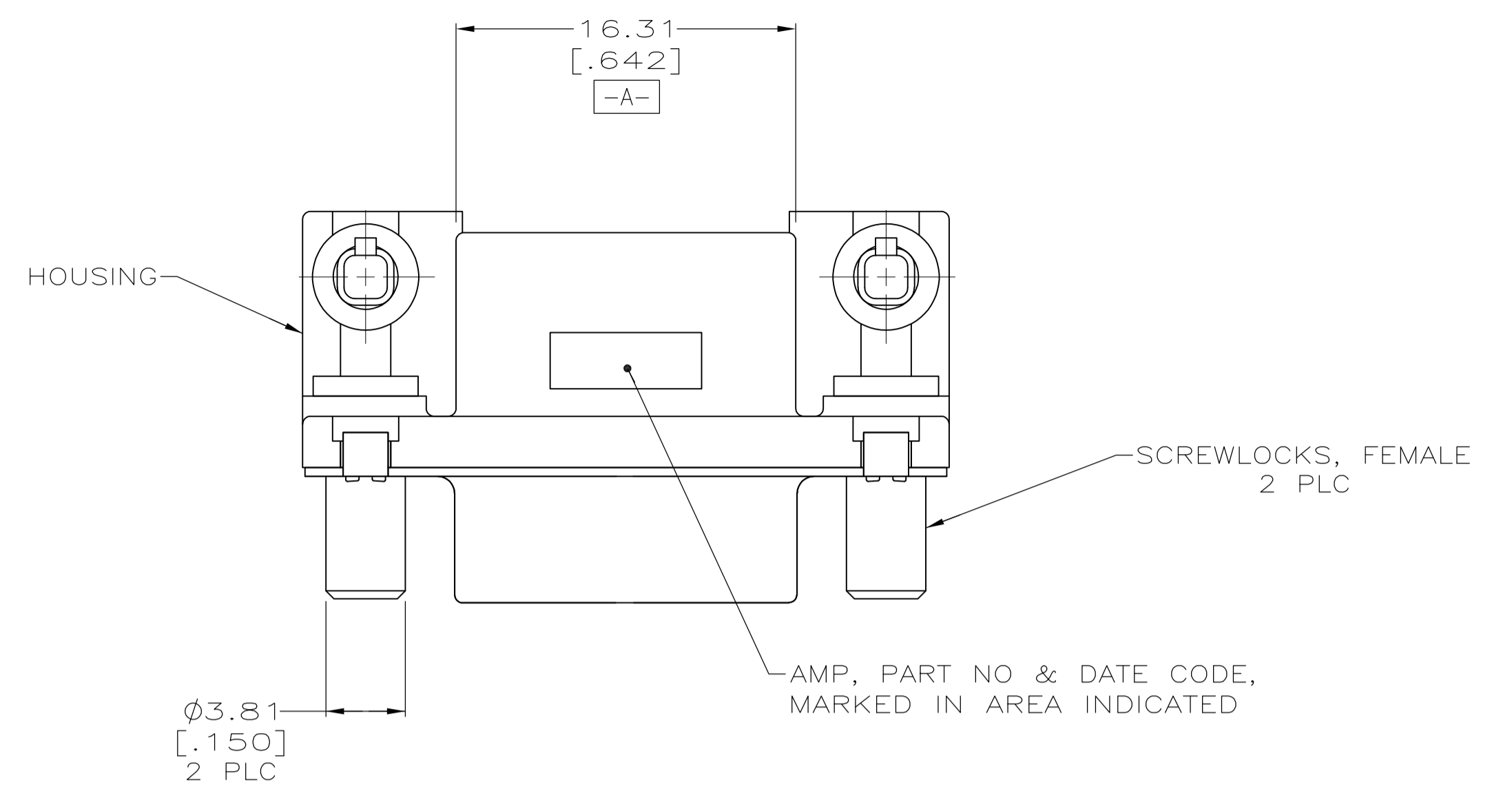

- △ HOUSING & FACE COVER: NYLON, THERMOPLASTIC, UL 94VO RATED, BLACK; SHELL: CARBON STEEL PER ASTM A109; SOCKET CONTACTS: PHOSPHOR BRONZE PER QQ-B-750; EYELETS: BRASS; SCREWLOCKS: ZINC; BOARDLOCKS: COPPER ALLOY.
- △ SOCKET CONTACTS: GOLD PLATED FOR A LENGTH OF 1.27 [.050] MIN FROM MATING END, 0.76µm [.000030] MIN GOLD IN MATED AREA, 2.54µm [.000100] MIN TIN OR TIN-LEAD FOR A LENGTH OF 3.56 [.140] MIN FROM OPPOSITE END, BOTH OVER 1.27µm [.000050] MIN NICKEL. EYELETS: 2.54µm [.000100] MIN TIN-LEAD OR TIN OVER COPPER FLASH. SHELL: 2.54µm [.000100] MIN TIN OVER 1.27µm [.000050] MIN COPPER. SCREWLOCKS: CLEAR CHROMATE. BOARDLOCKS: 3.81µm [.000150] MIN TIN-LEAD OVER 1.27µm [.000050] MIN NICKEL.
- △ SOCKET CONTACTS: GOLD PLATED FOR A LENGTH OF 1.27 [.050] MIN FROM MATING END, GOLD FLASH IN MATED AREA, 2.54µm [.000100] MIN TIN OR TIN-LEAD FOR A LENGTH OF 3.56 [.140] MIN FROM OPPOSITE END, BOTH OVER 1.27µm [.000050] MIN NICKEL. EYELETS: 2.54µm [.000100] MIN TIN-LEAD OR TIN OVER COPPER FLASH. SHELL: 2.54µm [.000100] MIN TIN OVER 1.27µm [.000050] MIN COPPER. SCREWLOCKS: CLEAR CHROMATE. BOARDLOCKS: 3.81µm [.000150] MIN TIN-LEAD OVER 1.27µm [.000050] MIN NICKEL.
- △ DATUMS AND BASIC DIMENSIONS ESTABLISHED BY CUSTOMER.
- △ POSITION TOLERANCE APPLIES AT CONTACT TIP.
- △ BOARDLOCKS WILL ACCEPT .062 MAX PRINTED CIRCUIT BOARD THICKNESS.
- 7. COMPATIBLE WITH TYPICAL HIGH TEMPERATURE SOLDERING APPLICATIONS TO A MAXIMUM OF 225°C FOR A MAXIMUM DURATION OF 90 SECONDS. TEMPERATURE TO BE MEASURED ON CONNECTOR SURFACE.
- △ SOCKET CONTACTS: GOLD PLATED FOR A LENGTH OF 1.27 [.050] MIN FROM MATING END, 0.76µm [.000030] MIN GOLD IN MATED AREA, 2.54µm [.000100] MIN TIN OR TIN-LEAD FOR A LENGTH OF 3.56 [.140] MIN FROM OPPOSITE END, BOTH OVER 1.27µm [.000050] MIN NICKEL. EYELETS: 2.54µm [.000100] MIN TIN-LEAD OR TIN OVER COPPER FLASH. SHELL: 2.54µm [.000100] MIN TIN OVER 1.27µm [.000050] MIN COPPER. SCREWLOCKS: CLEAR CHROMATE. BOARDLOCKS: 3.81µm [.000150] MIN TIN OVER 1.27µm [.000050] MIN NICKEL.
- △ SOCKET CONTACTS: GOLD PLATED FOR A LENGTH OF 1.27 [.050] MIN FROM MATING END, GOLD FLASH IN MATED AREA, 2.54µm [.000100] MIN TIN OR TIN-LEAD FOR A LENGTH OF 3.56 [.140] MIN FROM OPPOSITE END, BOTH OVER 1.27µm [.000050] MIN NICKEL. EYELETS: 2.54µm [.000100] MIN TIN-LEAD OR TIN OVER COPPER FLASH. SHELL: 2.54µm [.000100] MIN TIN OVER 1.27µm [.000050] MIN COPPER. SCREWLOCKS: CLEAR CHROMATE. BOARDLOCKS: 3.81µm [.000150] MIN TIN OVER 1.27µm [.000050] MIN NICKEL.
- △ OBSOLETE PARTS: OBSOLETE CIS STREAMLINING PER D.RENAUD/D.SINISI

△10	OBSOLETE	-	△9	6-788797-8
△10	OBSOLETE	-	△8	6-788797-7
	OBSOLETE	TUBE	△7	788797-3
	SUP BY 5788797-2	-	△6	788797-2
	-	-	△5	788797-1
	PACKAGING	FINISH	PART NUMBER	

THIS DRAWING IS A CONTROLLED DOCUMENT.

DIN D.BROCKWAY 08 MAR 00  
 CIK J.KOPPENHEFFER 09 MAR 00  
 APVD J.KOPPENHEFFER 09 MAR 00

Tyco Electronics Corporation  
 Harrisburg, PA 17105-3608

RCPT ASSEMBLY, SIZE 1, 318 SERIES, WITH FRONT METAL SHELL, HIGH TEMPERATURE, AMPLIMITE™ HD-20

108-40025

114-40010

00779 C=788797

SCALE 4:1 SHEET 1 OF 1 REV C1