

NOTES: UNLESS OTHERWISE SPECIFIED

1. CONSTRUCTION:
 HOUSING & PLUNGER & SLIDE: MOLDED NYLON. AVAILABLE IN TEN COLORS.
 CONTACT NEEDLE & SPRING: STAINLESS STEEL.
 BANANA SOCKET: BRASS.
2. PERFORMANCE:
 MAXIMUM CURRENT: 500 mA
 MAXIMUM VOLTAGE: 300 V
 MAXIMUM TEMPERATURE: 200°F (93°C)

2. FEATURES:
 NEEDLE PIERCES WIRE $\phi 0.050$ [$\phi 1.27$] TO $\phi 0.15$ [$\phi 3.81$].
 DOUBLE BANANA SOCKET ACCEPTS SHROUDED AND UNSHROUDED
 STANDARD BANANA PLUGS ON BOTH ENDS OF THE HANDLE.

LTR	REVISIONS		DATE	APPROVED
	DESCRIPTION			
A	BANANA SOCKET WAS P/N 0755 IS P/N 01044		6/15/10	S.B.W.

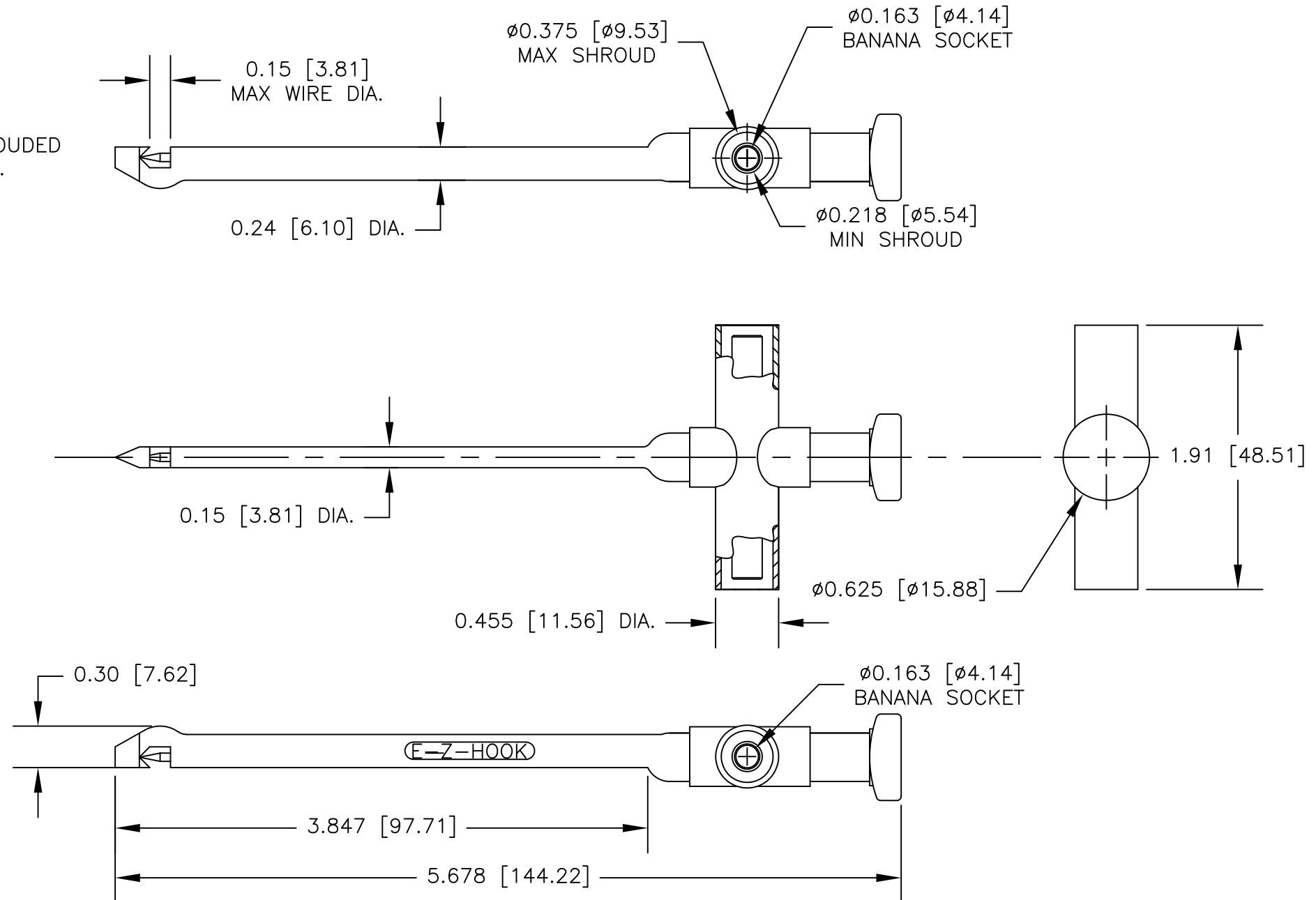

		UNLESS OTHERWISE SPECIFIED DIMENSIONS ARE IN INCHES TOLERANCES ARE: FRACTIONS DECIMALS ANGLES ± .XX ± ± .XXX ±	CONTRACT NO.		E-Z-HOOK DIVISION OF TEKTEST INC. ARCADIA, CA 91006 U.S.A.
			APPROVALS	DATE	
		MATERIAL SEE NOTE.	DRAWN S.B.W.	3/98	DESCRIPTION E-Z-MACRO HOOK INSULATION-PIERCING
		FINISH SEE NOTE.	APPROVED BY		
NEXT ASSY	USED ON				SIZE B
APPLICATION		DO NOT SCALE DRAWING			CODE IDENT NO. 08505
					DRAWING NO. XEL
					REV. A
					SCALE 1:1
					SHEET 1 OF 1