

SE-330 MANUAL NEUTRAL-GROUNDING-RESISTOR MONITOR

REVISION 11-A-063018

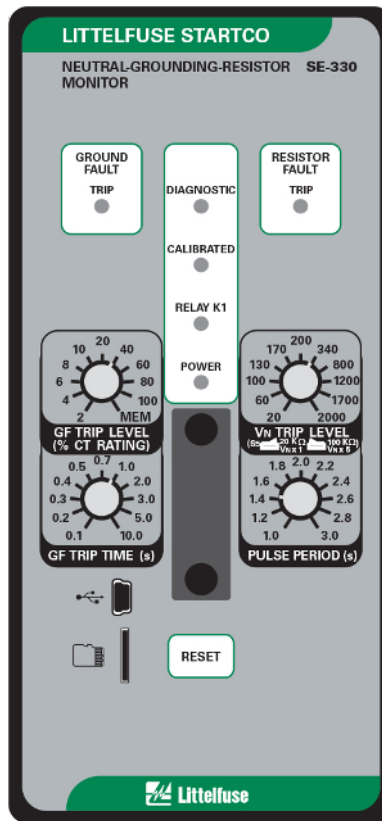

Copyright © 2018 by Littelfuse
All rights reserved.

This page intentionally left blank.

TABLE OF CONTENTS

1 GENERAL 1
 1.1 Modern Resistance-Grounded Systems 1
 1.2 SE-330 NGR Monitoring 1
 1.3 NGR Short Detection 2

2 OPERATION 2
 2.1 Settings 2
 2.1.1 GF Trip Time 2
 2.1.2 GF Trip Level 2
 2.1.3 V_N Trip Level 2
 2.1.4 Pulse-Period Adjustment 3
 2.1.5 Configuration Settings 4
 2.1.5.1 Relay K1 Function (S1) 4
 2.1.5.2 Trip-Relay Mode and Trip-Memory Mode (S2) 4
 2.1.5.3 Ground-Fault-Trip Latch (S3) 4
 2.1.5.4 Resistor-Fault-Trip Latch (S4) 4
 2.1.5.5 Sensing-Resistor Selection (S5) 4
 2.1.5.6 Frequency (S6) 4
 2.1.5.7 Upgrade Mode (S8) 4
 2.1.6 Resistor-Fault Trip Time 4
 2.1.7 Resistor-Fault Trip Level 4
 2.1.8 Geo-Magnetic Filter 4
 2.2 Calibration 5
 2.3 Pulsing Operation 5
 2.4 Trip Indication and Reset 5
 2.5 Remote Operation 5
 2.6 Relay K1 LED 6
 2.7 Unit Healthy Output 6
 2.8 Diagnostic LED 6
 2.9 Enhanced Health Status 6
 2.10 Analog Output 6

3 INSTALLATION 6
 3.1 SE-330 6
 3.2 Sensing Resistor 12
 3.3 Ground-Fault CT 20
 3.4 Isolated Ground Connection 24
 3.5 Pulsing Connection 24

4 DATA INTERFACES 25
 4.1 SD Card 25
 4.1.1 Datalogging 25
 4.1.2 Firmware Upgrade 25
 4.2 USB Interface 25
 4.3 Network Communications 26

5 TROUBLESHOOTING 27

6 TECHNICAL SPECIFICATIONS 29
 6.1 SE-330 29
 6.2 Sensing Resistors 31
 6.3 Current Sensors 32

7 ORDERING INFORMATION 34

8 WARRANTY 35

9 TEST PROCEDURES 35
 9.1 Resistor-Fault Tests 35
 9.1.1 Calibration and Open Test 35
 9.1.2 Voltage Test 35
 9.2 Sensing-Resistor Test 35
 9.3 Analog-Output Test 36
 9.4 Ground-Fault Performance Test 36

APPENDIX A SE-330 REVISION HISTORY 37

LIST OF FIGURES

1 Configuration switches 4
2 Analog-output connections 6
3 SE-330 connection diagram 7
4 SE-330 outline and panel-mounting details 8
5 SE-330 outline and surface-mounting details 9
6 SE-IP65CVR-G weatherproof cover outline 10
7 SE-IP65CVR-G weatherproof cover installation 11
8 ER-600VC sensing resistor 12
9 SE-MRE-600 moisture-resistant enclosure outline 13
10 ER-600VC installed in SE-MRE-600 14
11 ER-5KV sensing resistor 15
12 ER-5WP sensing resistor 16
13 ER-15KV sensing resistor 17
14 ER-25KV sensing resistor 18
15 ER-35KV sensing resistor 19
16 ELCT5-88 and ELCT30-88 ground-fault current sensors 21
17 ELCT5-31 and ELCT30-31 ground-fault current sensors 22
18 RK-332 remote indication and reset 23
19 PGA-0520 analog percent current meter 23
20 Simplified isolated-ground connection 24
21 Simplified pulsing connection 24
22 Ground-fault test circuits 36

LIST OF TABLES

1 Typical tripping system values 3
2 Ground-fault trip levels for selected CTs 3
3 Ground-fault-test record 36

DISCLAIMER

Specifications are subject to change without notice. Littelfuse, Inc. is not liable for contingent or consequential damages or for expenses sustained as result of incorrect application, incorrect adjustment, or malfunction.

This page intentionally left blank.

1. GENERAL

1.1 Modern Resistance-Grounded Systems

A high-resistance-grounded system uses a neutral-grounding resistor (NGR) with a low let-through current to limit the ground-fault current. This is an improvement from low-resistance and solidly grounded systems, which do not use NGRs and therefore have a ground-fault flash hazard that can cause substantial point-of-fault damage. High-resistance grounding eliminates these problems. Modern ground-fault protection reliably operates at low current levels. Furthermore, the probability of an arc-flash incident is significantly reduced in high-resistance-grounded systems.

NGR selection depends on system charging current and whether the system is an alarm-only or a tripping system. Alarm-only systems are usually restricted to system voltages up to 5 kV with NGR let-through currents of 5 A or less. Occasionally, alarm-only systems up to 15 kV and 10 A are used, however, these systems are not common because a ground fault on such a system tends to escalate to a phase-to-phase fault before the ground fault can be located and cleared. Consult Canadian Electrical (CE) Code rule 10-302, National Electric Code (NEC)* 250.36, and NEC 250.186 for application details.

System charging current is the capacitive current that flows to ground when a bolted ground fault occurs. This current can be calculated or measured. For small systems, the magnitude of charging current may be conservatively estimated as ½ A per 1,000 kVA in low-voltage systems and 1 A per 1,000 kVA in medium-voltage systems.

In an alarm-only system or in a tripping system without selective coordination, use an NGR with a let-through current larger than the system charging current. Set the pick-up current of ground-fault devices at or below 50% of the NGR let-through current.

In a tripping system with selective coordination, use ground-fault devices that have a definite-time characteristic to achieve time coordination. Use the same pick-up current for all ground-fault devices, which must be a larger value than the charging current of the largest feeder. Select an NGR with a let-through current between five and 10 times the pick-up current of the ground-fault devices.

Do not use a grounding transformer with a low-voltage resistor:

- The combined cost of a transformer and a low-voltage resistor is more than the cost of a resistor that is rated for line-to-neutral voltage.
- A transformer saturated by a ground fault through a rectifier can make ground-fault protection inoperative.
- Transformer inrush current up to 12 times the rated current can cause a voltage that is larger than expected.
- A parallel transformer winding makes it difficult to monitor NGR continuity.

- A transformer can provide the inductance necessary to cause ferroresonance if the NGR opens.

Following these guidelines will reduce the flash hazard, reduce point-of-fault damage, achieve reliable ground-fault protection, and ensure a stable system not subject to ferroresonance.

1.2 SE-330 NGR Monitoring

The SE-330 is a microprocessor-based NGR monitor that detects NGR failures and ground faults in resistance-grounded systems and is compliant with the 2018 CE Code. The SE-330 measures NGR resistance, NGR current, and transformer or generator neutral-to-ground voltage. The components required to monitor an NGR are an SE-330, a 20- or 100-kΩ ER-series sensing resistor, and a current transformer (CT).

Power-circuit elements (other than neutral-connected NGRs) that purposefully connect the power system to ground are often not compatible with SE-330 NGR monitoring. These elements include single-phase grounding transformers, grounded-wye-primary potential transformers, and grounded-wye-primary power transformers.

The SE-330 continuously measures NGR resistance in an unfaulted system. It will trip on resistor fault if the NGR resistance varies from its calibrated value. When a ground fault occurs, voltage is present on the neutral. NGR current will flow if the NGR is healthy. The SE-330 will trip on ground fault if fault current exceeds the GF TRIP LEVEL setting for an interval equal to the GF TRIP TIME setting. However, if the NGR fails open during a ground fault, it is possible for fault resistance to satisfy the NGR resistance measurement. To detect this double-fault condition, the SE-330 measures neutral voltage. If neutral voltage exceeds the V_N TRIP LEVEL setting and if NGR current is less than 5% of the CT rating, the SE-330 will trip on resistor fault. If the resistor-fault circuit is tripped and the neutral voltage exceeds the V_N TRIP LEVEL setting for an interval greater than the GF TRIP TIME setting, the ground-fault circuit will also trip.

Ground-fault current is sensed by a CT with a 1- or 5-A secondary, or by a CT (ELCT5-x or ELCT30-x) with a 50-mA secondary. The trip level of the ground-fault circuit is adjustable from 2 to 100% of the CT rating. The trip time is adjustable from 0.1 to 10.0 seconds.

The SE-330 has four output relays. With firmware version 3.00 or higher, relays K1, K2, and K3 can be assigned to one of the following functions (using SE-MON330 version 4.0 or higher):

- Ground Fault (GF);
- Resistor Fault (RF);
- Enhanced Health Status (HEALTH);
- GF + RF;
- GF + RF + HEALTH; or
- DISABLED.

In addition to the selected function, K1 is also assigned a trip or pulsing function. When the pulsing function is selected, relay K1 is used to control a contactor to assist in locating faults. Relays K1, K2, and K3 can be set to operate in the fail-safe or non-fail-safe mode for undervoltage or shunt-trip applications. Relay K4 is a solid-state relay that provides basic UNIT HEALTH indication.

Additional features include LED trip indication, trip memory, front-panel and remote reset, 4-20-mA analog output, trip event recorder, USB local communications, microSD* data logging, and optional network communications.

The SE-330 provides additional features over the SE-330 legacy model (revision 04 or less):

- NGR short detection capability.
- Configurable output relay function and operating mode (K1, K2, and K3).
- When the trip level is set to MEM, the ground-fault trip setting is defined by an internal non-volatile memory variable. The range is 2 to 100% in 1% increments of the CT-primary rating.
- The number of trip records has been increased to 100 and includes date and time stamping.
- A microSD card interface can be used for short-term data logging and firmware updates. A microSD card is included. See Section 4.1.
- For ease of connection to new devices, the RS-232 interface has been replaced by a Mini-B USB port.
- Dual Ethernet ports are available with support for fiber-optic and RJ45 interfaces.
- An added IEC61850 protocol.

1.3 NGR Short Detection (firmware version 3.00 and higher)

The SE-330 can be configured to monitor and trip if the NGR resistance decreases to a value less than 10 to 70% of the Nominal NGR Resistance value. The Nominal NGR Resistance, NGR Short Trip Level, and several other values can be configured using SE-MON330 (version 4.0 or higher). Refer to the SE-MON330 manual for further details.

2. OPERATION

2.1 Settings

2.1.1 GF Trip Time

GF TRIP TIME (definite time) is adjustable from 0.1 to 10.0 seconds. Time-coordinated ground-fault protection requires this setting to be longer than the trip times of downstream ground-fault devices.

A trip-time accumulator provides a ground-fault memory function for detection of intermittent faults. The accumulated time increases when a ground fault is detected and decreases when a ground fault

is not detected. A trip will eventually occur when the time for fault current above the trip level is greater than the time for fault current below the trip level.

A non-accumulating mode can also be selected. In this mode, a trip occurs if the fault current remains higher than the ground-fault trip level for the duration of the ground-fault trip time.

2.1.2 GF Trip Level

The SE-330 uses a Discrete-Fourier Transform (DFT) algorithm to measure the fundamental component of NGR current.

Choose an NGR let-through current and a ground-fault trip level using the guidelines in Section 1.1. Set the ground-fault trip level between 2 and 100% of the CT-primary rating. When the ground-fault trip level is set to MEM, the ground-fault setting that is stored in non-volatile memory is used. This parameter must be set using a PC running the SE-MON330 software and connected to the USB interface. The setting range is 2 to 100% of CT primary rating in 1% increments. The default value is 15%. Inputs are provided for 5-, 1-, and 0.05-A secondary CTs. Typical values for 5-, 15-, and 25-A tripping systems are shown in Table 1. Ground-fault trip levels for the selected CTs are shown in Table 2. For other systems, refer to the NGR Monitor Set-Point Assistant at www.littelfuse.com/relayscontrols. The Set-Point Assistant is included with the SE-MON330 software.

2.1.3 V_N Trip Level

The SE-330 uses a DFT algorithm to measure the fundamental component of neutral voltage (V_N).

The SE-330 will trip and indicate a resistor fault if neutral voltage is greater than the V_N TRIP LEVEL setting for the duration of the resistor-fault trip time, and ground-fault current is less than 5% of the CT rating. If the resistor-fault circuit is tripped and the neutral voltage exceeds the V_N TRIP LEVEL setting for an interval greater than the GF TRIP TIME setting then the ground-fault circuit will also trip.

The V_N TRIP LEVEL range is 20 to 2,000 V when switch S5 is in the 20-k Ω ($V \times 1$) position, and the range is 100 to 10,000 V when switch S5 is in the 100-k Ω ($V \times 5$) position. Calculate the voltage across the NGR when the NGR current is equal to the pick-up current of the ground-fault circuit. Set the V_N TRIP LEVEL to the next largest value. See Fig. 1 and Section 2.1.5.5.

Typical values for 5-, 15-, and 25-A tripping systems are shown in Table 1. For an NGR resistance greater than 2 k Ω , use a 100-k Ω sensing resistor. For other systems, refer to the NGR Monitor Set-Point Assistant at www.littelfuse.com/relayscontrols.

NOTE: A resistor-fault trip is inhibited if the ground-fault current is above 5% of the CT rating.

TABLE 1. Typical tripping system values

SYSTEM VOLTAGE (LINE-TO-LINE)	NEUTRAL-GROUNDING RESISTOR		SENSING RESISTOR		GROUND-FAULT TRIP LEVEL	V _N TRIP LEVEL
	(VOLTS)	CURRENT (AMPERES)	RESISTANCE (OHMS)	MODEL	RESISTANCE (SWITCH S5 SETTING)	(AMPERES)
480	5	55	ER-600VC	20 kΩ	1.0	60
600	5	69	ER-600VC	20 kΩ	1.0	100
2,400	5	277	ER-5KV	20 kΩ	1.0	340
4,160	5	480	ER-5KV	20 kΩ	1.0	800
480	15	18	ER-600VC	20 kΩ	3.0	60
600	15	23	ER-600VC	20 kΩ	3.0	100
2,400	15	92	ER-5KV	20 kΩ	3.0	340
4,160	15	160	ER-5KV	20 kΩ	3.0	800
7,200	15	277	ER-15KV	100 kΩ	3.0	170x5 = 850
14,400	15	554	ER-15KV	100 kΩ	3.0	340x5 = 1,700
4,160	25	96	ER-5KV	20 kΩ	5.0	800
7,200	25	166	ER-15KV	100 kΩ	5.0	170x5 = 850
14,400	25	332	ER-15KV	100 kΩ	5.0	340x5 = 1,700
25,000	25	577	ER-25KV	100 kΩ	5.0	800x5 = 4,000
35,000	25	808	ER-35KV	100 kΩ	5.0	1,200x5 = 6,000

TABLE 2. Ground-fault trip levels for selected CTs

GF TRIP LEVEL(%) ⁽¹⁾	ELCT5-x EFCT-x 5:0.05 (AMPERES)	ELCT30-x SE-CS30-x 30:0.05 (AMPERES)	50:1 50:5 (AMPERES)	100:1 100:5 (AMPERES)	200:1 200:5 (AMPERES)	400:1 400:5 (AMPERES)
2	0.10	0.60	*	*	*	*
4	0.20	1.20	*	*	*	16
6	0.30	1.80	*	*	12	24
8	0.40	2.40	*	8	16	36
10	0.50	3.00	5	10	20	40
20	1.00	6.00	10	20	40	80
40	2.00	12.00	20	40	80	160
60	3.00	18.00	30	60	120	240
80	4.00	24.00	40	80	160	320
100	5.00	30.00	50	100	200	400

⁽¹⁾ When set to MEM, range is 2 to 100% in 1% increments.

* Setting not recommended.

2.1.4 Pulse-Period Adjustment

Pulse period is the cycle time of relay K1 when the SE-330 is configured for pulsing operation. Pulse period is adjustable from 1.0 to 3.0 seconds with a fixed duty cycle of 50 percent. For example, with the 1.0-s setting, relay K1 will be energized for 0.5 seconds and de-energized for 0.5 seconds when pulsing is enabled.

See Section 2.3 for detailed pulsing operation information.

NOTE: For pulsing configuration, set switch S1 to K1 = PULSING and install an external pulse-enable switch.

2.1.5 Configuration Settings

Eight configuration switches (S1 to S8) and a calibration button are located behind the access cover on the front panel. See Fig. 1.

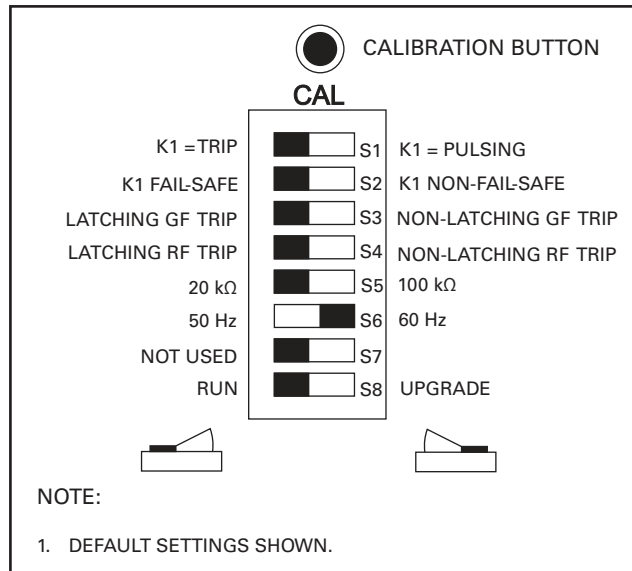

FIG. 1. Configuration switches.

2.1.5.1 Relay K1 Function (S1)

Set switch S1 to K1 = TRIP to assign the trip function to relay K1 and to activate switch S2. With the default setting, relay K1 will change state when a resistor-fault or ground-fault trip occurs. Other trip functions can be assigned to K1 using SE-MON330 software or via network communications.

Set switch S1 to K1 = PULSING to configure relay K1 for pulsing operation. See Section 2.3.

2.1.5.2 Trip-Relay Mode And Trip-Memory Mode (S2)

Set switch S2 to select the operating mode of trip relay K1. In the non-fail-safe mode, relay K1 energizes and its contact closes when a trip occurs. The non-fail-safe mode can be used to trip shunt-trip circuit breakers. In the non-fail-safe mode, SE-330 trips are reset when supply voltage is cycled.

In the fail-safe mode, relay K1 energizes and its contact will close if there are no trips. The contact will open in the event of a trip, a loss of supply voltage, or a processor failure. In the fail-safe mode, SE-330 trips are not reset when the supply voltage is cycled.

NOTE: Switch S2 does not affect the operating modes of relays K2, K3, and K4.

NOTE: Switch S2 only affects relay K1 operating mode when K1 is assigned the trip function (switch S1 set to K1 = TRIP). Trip memory is enabled when K1 is set to the fail-safe mode, regardless of the switch S1 setting.

2.1.5.3 Ground-Fault-Trip Latch (S3)

Set switch S3 to select latching or non-latching ground-fault-circuit operation. Non-latching operation overrides ground-fault-trip memory. See Sections 2.1.5.2 and 2.4.

2.1.5.4 Resistor-Fault-Trip Latch (S4)

Set switch S4 to select latching or non-latching resistor-fault-circuit operation. Non-latching operation overrides resistor-fault-trip memory. See Sections 2.1.5.2 and 2.4.

2.1.5.5 Sensing-Resistor Selection (S5)

Set switch S5 to the resistance of the sensing resistor. For the ER-600VC, ER-5KV, and ER-5WP, select 20 kΩ. For the ER-15KV, ER-25KV, and ER-35KV, select 100 kΩ. Switch S5 sets the resistor-fault trip value and the V_N TRIP LEVEL range. See Section 2.1.3.

2.1.5.6 Frequency (S6)

Set switch S6 to 50 or 60 Hz to tune the digital filter to the line frequency of the monitored system.

2.1.5.7 Upgrade Mode (S8)

The microSD card is used for firmware upgrades. See Section 4.1.2 for upgrade instructions.

NOTE: An upgrade causes an SE-330 restart and this may cycle the output relays.

2.1.6 Resistor-Fault Trip Time

The resistor-fault trip time can be adjusted from from 12 seconds (the default) to as much as 60 seconds using the SE-MON330 software or via network communications.

2.1.7 Resistor-Fault Trip Level

The resistor-fault trip level can be adjusted using the SE-MON330 software or via network communications. See Section 6.1.

2.1.8 Geo-Magnetic Filter

A low-frequency ground current can be caused by the Earth's magnetic field and from charged clouds passing overhead during a thunderstorm. In some conditions, this can cause a false resistor-fault trip. Enabling the geo-magnetic filter and increasing the resistor-fault trip time can help counteract these effects.

A trip time of 30 seconds is recommended when the geo-magnetic filter is enabled.

The geo-magnetic filter is disabled by default but can be enabled using the SE-MON330 software or via network communications.

2.2 Calibration

The SE-330 measures the resistance change of the NGR relative to the NGR-resistance value that was determined at the time of calibration. When the resistance change is greater than the threshold amount (500 Ω for 20-k Ω systems and 2,500 Ω for 100-k Ω systems), a resistor-fault trip will occur. The SE-330 should be calibrated for new installations, or if the NGR or the sensing resistor is changed.

NOTE: If the SE-330 is not calibrated and is supplied from the load side of the breaker (non-fail-safe mode), calibrate it within the resistor-fault trip time after power-up or it may trip and interrupt its supply. See Section 2.1.6.

The CALIBRATION button is located behind the access cover on the front panel, and is recessed to prevent inadvertent activation.

NOTE: Calibration must be performed with the SE-330 connected to the sensing resistor and NGR of the installed system.

To calibrate the SE-330, press and hold the CALIBRATION button until the green CALIBRATED LED turns off and then turns on (if the LED is already off, press and hold down the button until the LED turns on). Calibration takes approximately two seconds. If calibration is not successful a resistor-fault trip occurs, the RESISTOR FAULT TRIP LED will be on, the CALIBRATED LED will be off, and the DIAGNOSTIC LED will flash the calibration-error code. See Section 2.8.

The SE-330 may be calibrated remotely using the SE-MON330 software with the USB interface or the communications options.

If the resistor fault (switch S4) is selected, the calibration-error code flashes until RESET is pressed even if the CALIBRATED LED is on.

The calibration value is stored in non-volatile memory.

2.3 Pulsing Operation

If switch S1 is set to K1 = PULSING, pulsing occurs when terminal 16 is connected to terminal 17. Relay K1 operates at a 50% duty cycle. The duration of each cycle can be adjusted from 1.0 to 3.0 seconds. When terminals 16 and 17 are not connected, K1 is not energized and its contact is open.

Relay K1 can be used to control a contactor that is rated for use at the line-to-neutral voltage. The contactor causes changes in neutral-to-ground resistance by adding or shorting portions of the NGR. See Section 3.5. Pulsing ground-fault current appears as zero-sequence current upstream from the fault.

Pulsing ground-fault current is distinguishable from charging current and noise, and it can be traced with a clip-on ammeter or current probe. If a pulsing current is detected on a cable or conduit, then the fault is downstream. Systematic testing allows faults to be located without isolating feeders or interrupting loads.

Stop pulsing when a fault is located.

2.4 Trip Indication And Reset

Red LEDs and indication relays indicate ground-fault and resistor-fault trips. The indication relays K2 (default is GF) and K3 (default is RF) operate in either fail-safe or non-fail-safe mode. The default is non-fail-safe mode. In this mode, the relays are energized when a fault occurs. The relay mode setting is stored in non-volatile memory and can be set using the SE-MON330 software or network communications.

When a trip occurs with latching operation selected, the SE-330 remains tripped until the unit is reset with the front-panel RESET button or the remote-reset input. See Sections 2.1.5.3 and 2.1.5.4. Terminals 15 and 16 are provided for remote reset as shown in Fig. 3. The reset circuit responds only to a momentary closure so that a jammed or shorted button does not prevent a trip. The front-panel RESET button is inoperative when terminal 15 is connected to terminal 16. If non-latching operation is selected, trips and corresponding indication will automatically reset when the fault clears. In addition, the power-up trip memory will be ignored even when configuration switch S2 is set to fail-safe. The maximum automatic reset time is 2.8 s.

The red DIAGNOSTIC LED annunciates latched calibration-error and remote trips. See Section 2.8.

When supply voltage is applied with switch S2 set to FAIL-SAFE, then the SE-330 returns to its state prior to loss of supply voltage unless switch S3 or S4 is set to non-latching. SE-330 trips reset when the supply voltage is applied with switch S2 set to NON-FAIL-SAFE. When a local, remote, or network reset is issued, both trip LEDs will flash if they are off.

Resistor-fault-trip reset can take up to one second. Resistor-fault trip-memory trip can take up to three seconds once the relay powers up.

2.5 Remote Operation

Relays K2 and K3 can be used for remote indication, and terminals 15 and 16 are provided for remote reset. RK-332 Remote Indication and Reset components are shown in Fig. 18. Connect them as shown in Fig. 3. RK-332 components are not polarity sensitive.

Indication relays can be set to fail-safe or non-fail-safe operation using the SE-MON330 software or network communications. The default mode is non-fail-safe. In non-fail-safe mode, relays energize on fault.

Network-enabled SE-330s can be remotely tripped and reset by the network master. The red DIAGNOSTIC LED indicates a network-initiated trip. See Section 2.8. Refer to the appropriate SE-330 communications manual.

2.6 Relay K1 LED

The yellow RELAY K1 LED follows the state of relay K1 and is on when K1 is energized (contact closed).

2.7 Unit Healthy Output

The UNIT HEALTHY relay K4 provides a basic status of processor health, which is energized when the processor is operating. It can be ordered with N.O. or N.C. contacts. See section 7.

An ENHANCED HEALTH status can be assigned to relays K1, K2, and K3. See Section 2.9.

UNIT HEALTHY relay K4 is energized when the processor is operating. It can be ordered with N.O. or N.C. contacts. See Section 7.

NOTE: The K4 output changes state momentarily during a processor reset.

NOTE: K4-contact rating is 100 mA maximum.

2.8 Diagnostic LED

The DIAGNOSTIC LED is used to annunciate trips without individual LED indication. The number of short LED pulses between pauses indicates the cause of the trip.

By default, only critical diagnostic flash codes are shown. Non-critical diagnostic codes include SD Card status and USB Error status. All other diagnostic codes are considered critical.

Starting with SE-330 firmware version 2.60 and SE-MON330 software version 3.8, the SE-330 can be configured to show only critical diagnostic codes. In this configuration, only critical diagnostic codes will be indicated with the DIAGNOSTIC LED. Diagnostic messages are always visible with the SE-MON330 software. See Sections 4.2 and 5.

2.9 Enhanced Health Status

The Enhanced Health Status can be assigned to relays K1, K2, and K3 (firmware version 3.00 and higher). The assigned relay(s) will trip when a critical diagnostic code occurs. See Section 5 for a list of critical diagnostic codes.

2.10 Analog Output

An isolated 4–20-mA output indicates NGR current with full-scale output corresponding to the CT rating. An internal 24-VDC supply allows the analog output to be connected as a self-powered output. Power from an external supply is required for loop-powered operation. See Fig. 2. A PGA-0520 analog meter can be panel-mounted to display the NGR current. See Fig. 19 and Section 7.

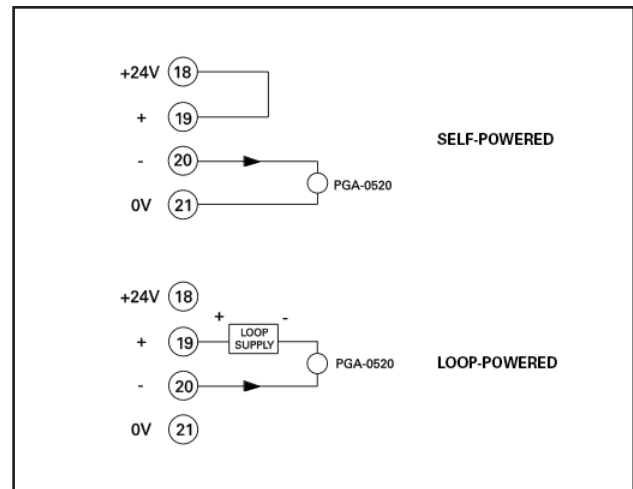

FIG. 2. Analog-output connections.

3. INSTALLATION

3.1 SE-330

Outline and panel-cutout dimensions for the SE-330 are shown in Fig. 4. To panel mount the SE-330, insert it through the panel cutout and secure it with the four included 8-32 locknuts and flat washers.

If an optional SE-IP65CVR-G hinged cover is used, follow the included installation instructions. See Figs. 6 and 7.

All connections to the SE-330 are made with plug-in, wire-clamping terminal blocks. Each plug-in terminal block can be secured to the SE-330 by two captive screws for reliable connections.

Outline dimensions and mounting details for surface mounting the SE-330 are shown in Fig. 5. Fasten the optional surface-mount adapter to the mounting surface and make connections to the adapter terminal blocks. Follow Fig. 5 instructions to mount or remove the SE-330.

Ground terminal 7 (G) and connect terminal 6 (R) to the sensing-resistor R terminal.

Use terminal 1 (L1) as the line terminal on ac systems, or the positive terminal on dc systems. Use terminal 2 (L2/N) as the neutral terminal on ac systems or the negative terminal on dc systems. Connect terminal 3 (⊕) to ground.

NOTE: Disconnect terminal 1 (L1) and terminal 2 (L2/N) before performing dielectric strength testing of the control panel.

NOTE: Connections to terminals 4 (SPG) and 5 (SPGA) are not required when using the SE-330 hardware revision 10 and higher. However, it is recommended to connect terminal 4 to terminal 5 to maintain backwards compatibility with the older SE-330 series (hardware revision 04A and lower).

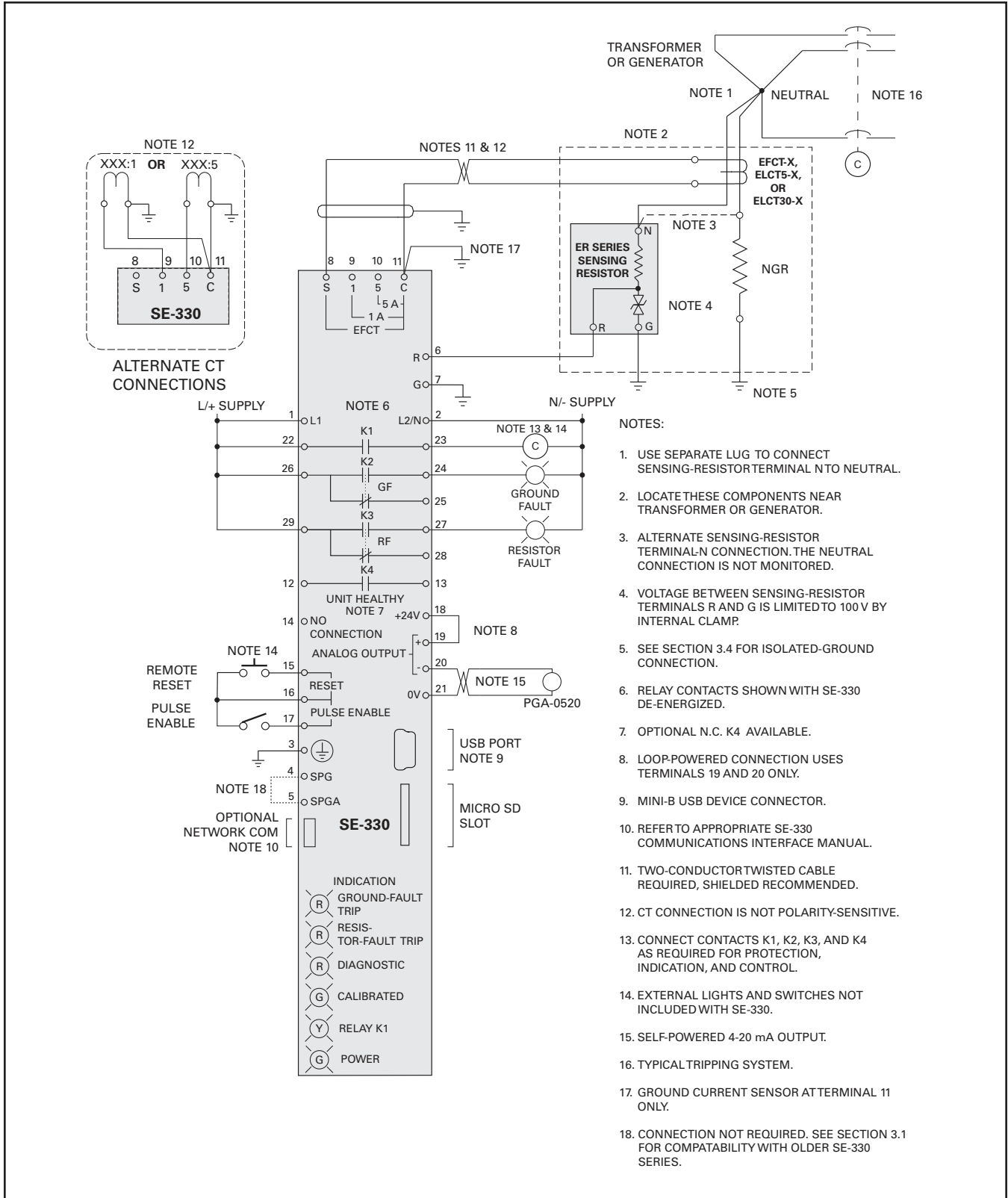

FIG. 3. SE-330 connection diagram.

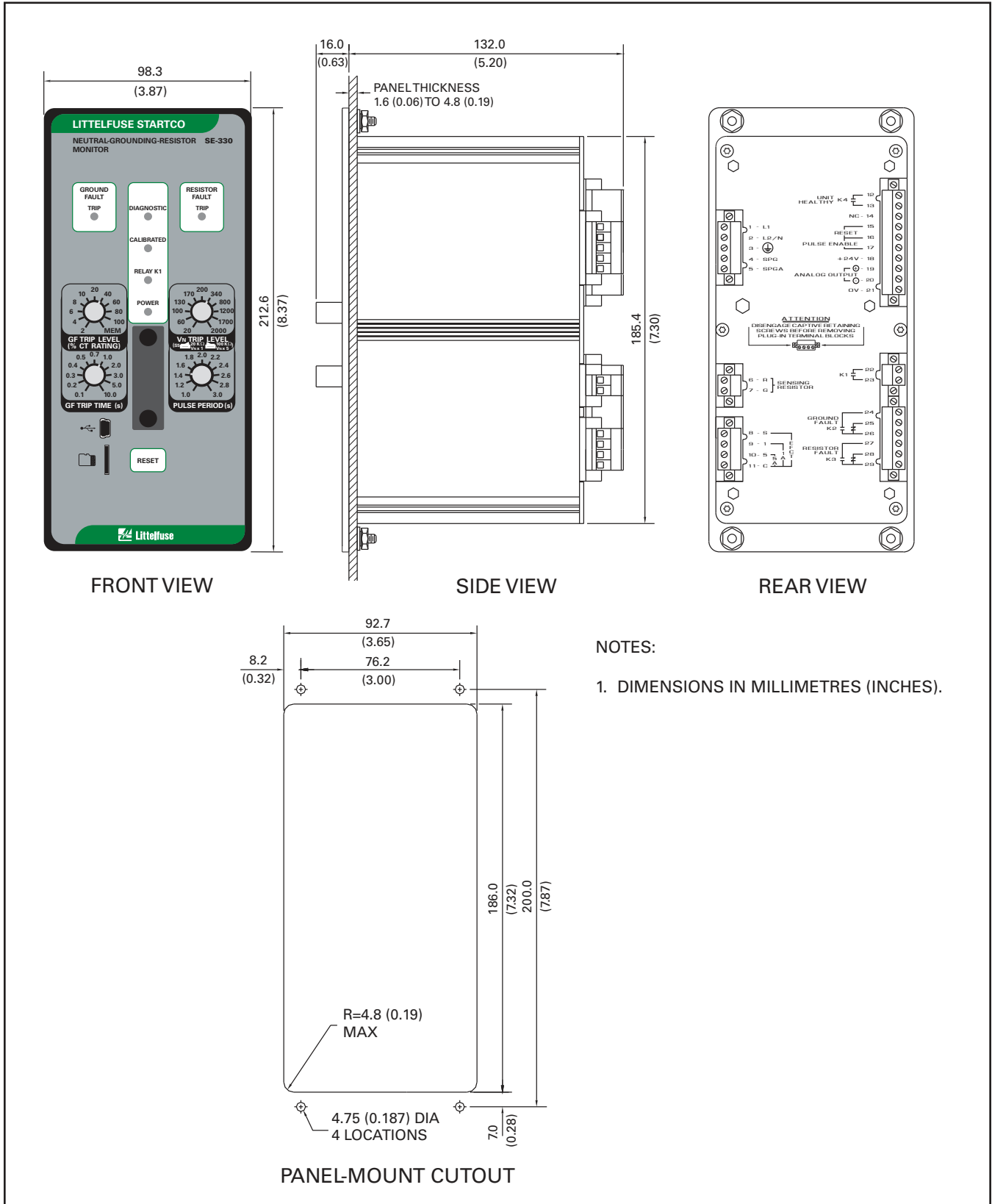

FIG. 4. SE-330 outline and panel-mounting details.

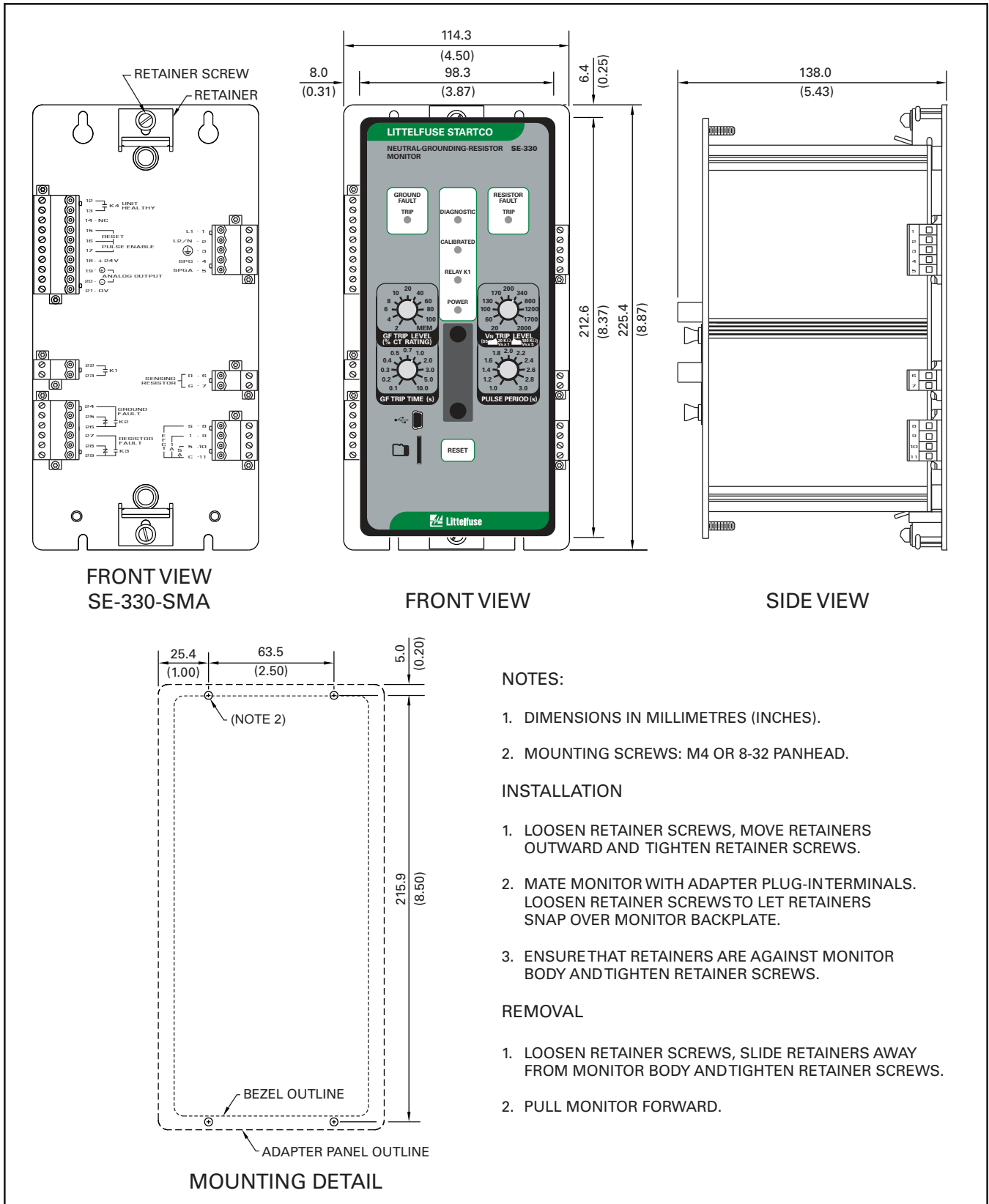

FIG. 5. SE-330 outline and surface-mounting details.

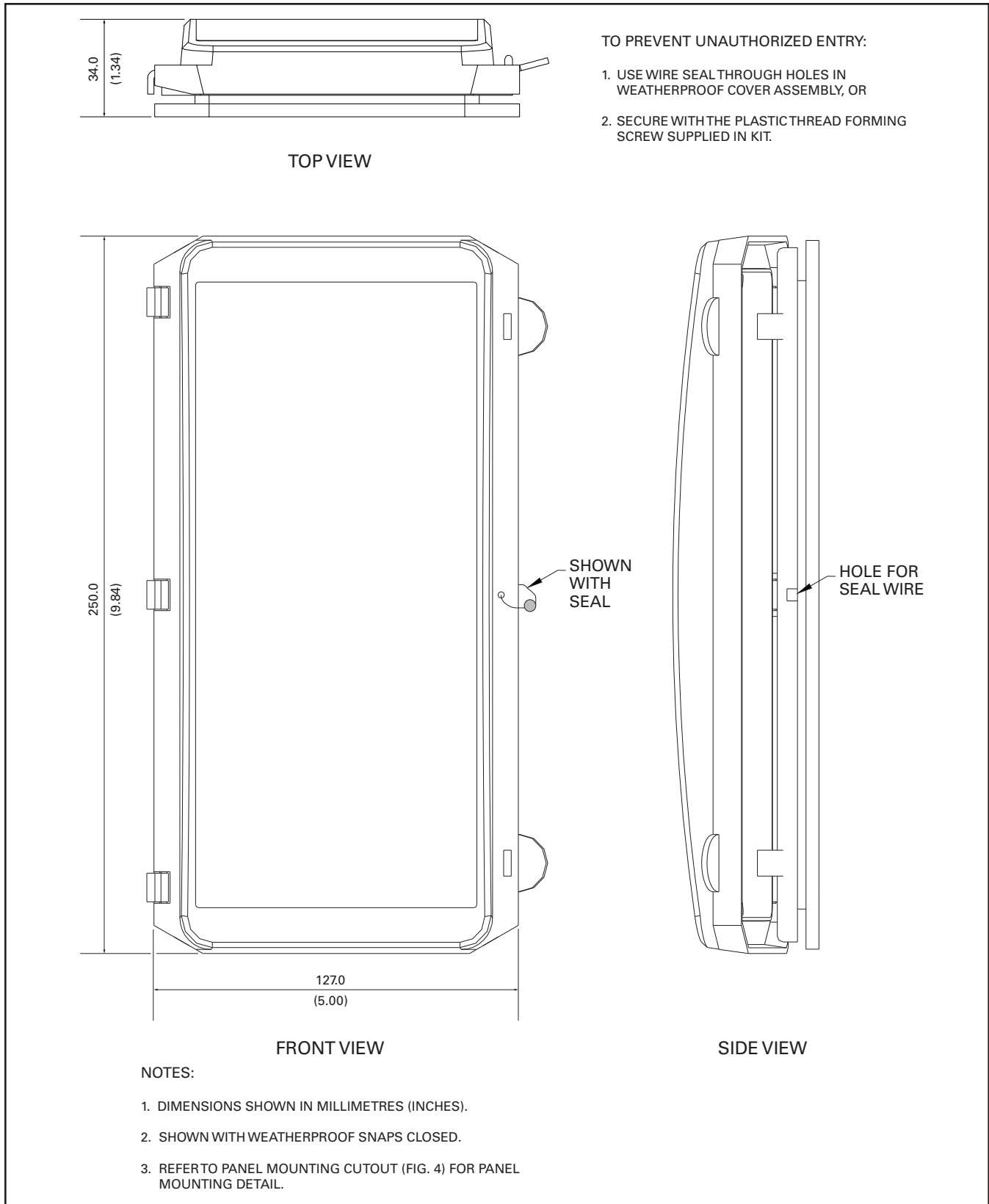

FIG. 6. SE-IP65CVR-G weatherproof cover outline.

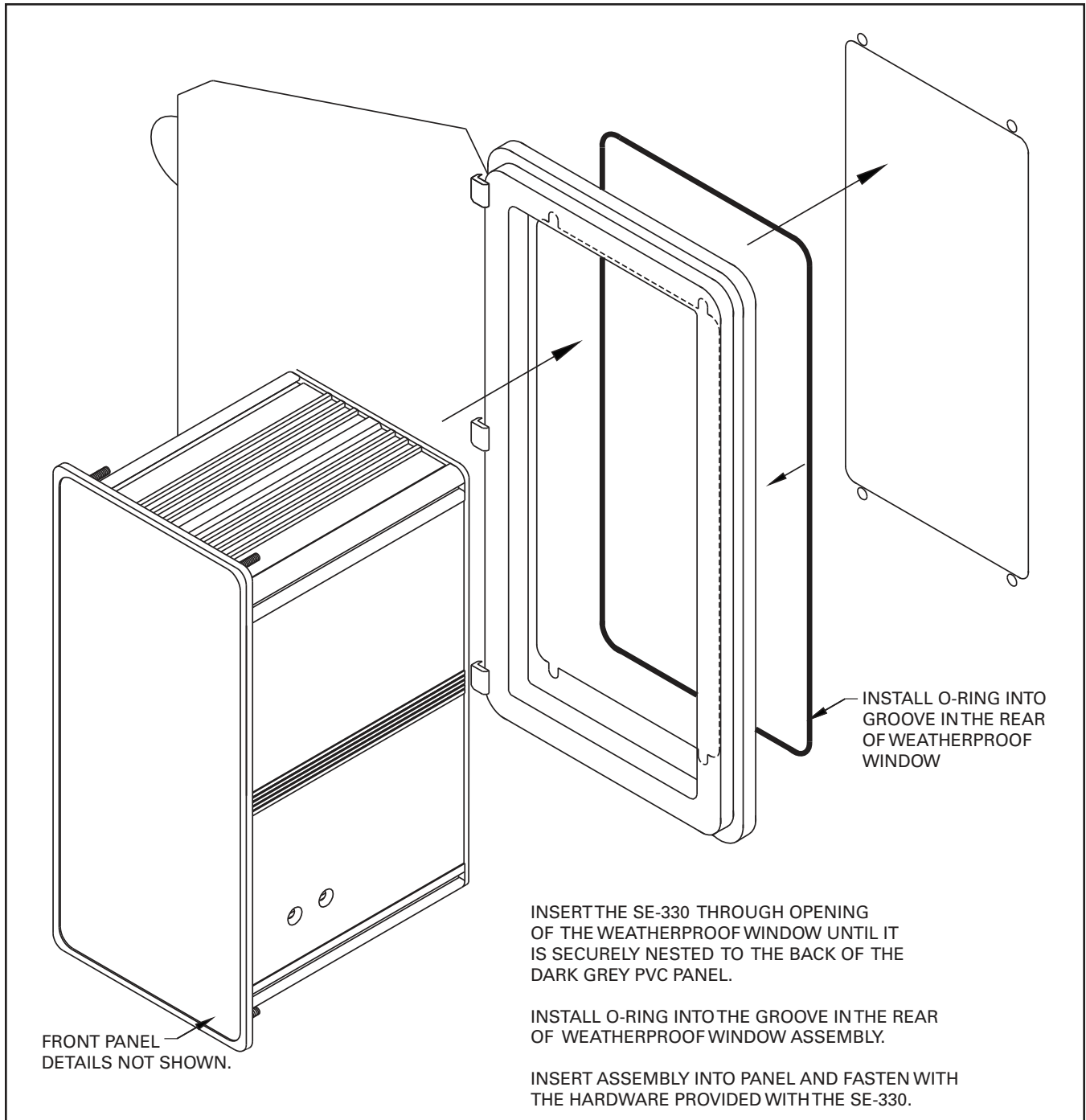

FIG. 7. SE-IP65CVR-G weatherproof cover installation.

3.2 Sensing Resistor

Outline and mounting details for the ER-600VC, ER-5KV, ER-5WP, ER-15KV, ER-25KV, and ER-35KV sensing resistors are shown in Figs. 8, 11, 12, 13, 14, and 15. Install the NGR and the sensing resistor near the transformer or generator. When installed outdoors, a sensing resistor must be installed in a suitable enclosure. An optional SE-MRE-600 Moisture-Resistant Enclosure is available for applications that may expose an ER-600VC to moisture. See Figs. 9 and 10. The weather-protected ER-5WP shown in Fig. 12 is an ER-5KV with moisture-resistant terminal covers. Use an ER-5WP in applications in which it might be exposed to moisture. The ER-15KV, ER-25KV, and ER-35KV include moisture-resistant terminal covers. Use suitable water-tight fittings. Ground sensing-resistor terminal G. Pass the sensing-resistor-to-neutral conductor and the NGR-to-neutral conductor through the ground-fault-CT window as shown in Fig. 3. Separately connect sensing-resistor terminal N and the NGR to the neutral to include neutral connections in the monitored loop. Alternatively, if the NGR connection to system neutral does not need to be monitored, connect terminal N to the NGR neutral terminal.

If a ground fault in the sensing-resistor conductor is unlikely and it does not pass through the ground-fault-CT window, then protection will be minimally lost. See Note 3 in Fig. 3.

NOTE: Voltage at terminal N rises to line-to-neutral voltage when a ground fault occurs. The same clearances are required for sensing resistors as for NGRs.

NOTE: A parallel ground path created by moisture can result in a false resistor-fault trip. Moisture sources include wind-driven rain or snow, and condensation. Sensing-resistor terminal R and its connection to SE-330 terminal R, including interposing terminal blocks, must remain dry.

NOTE: The neutral-to-sensing-resistor-terminal-N connection is not a neutral conductor as defined in Canadian Electrical Code Rule 10-308 and National Electrical Code Section 250.36(B). It is not required to be 8 AWG (8.36 mm²) or larger. Since current through this conductor is always less than 250 mA, a 14 AWG (2.08 mm²) conductor insulated to the system voltage is sufficient.

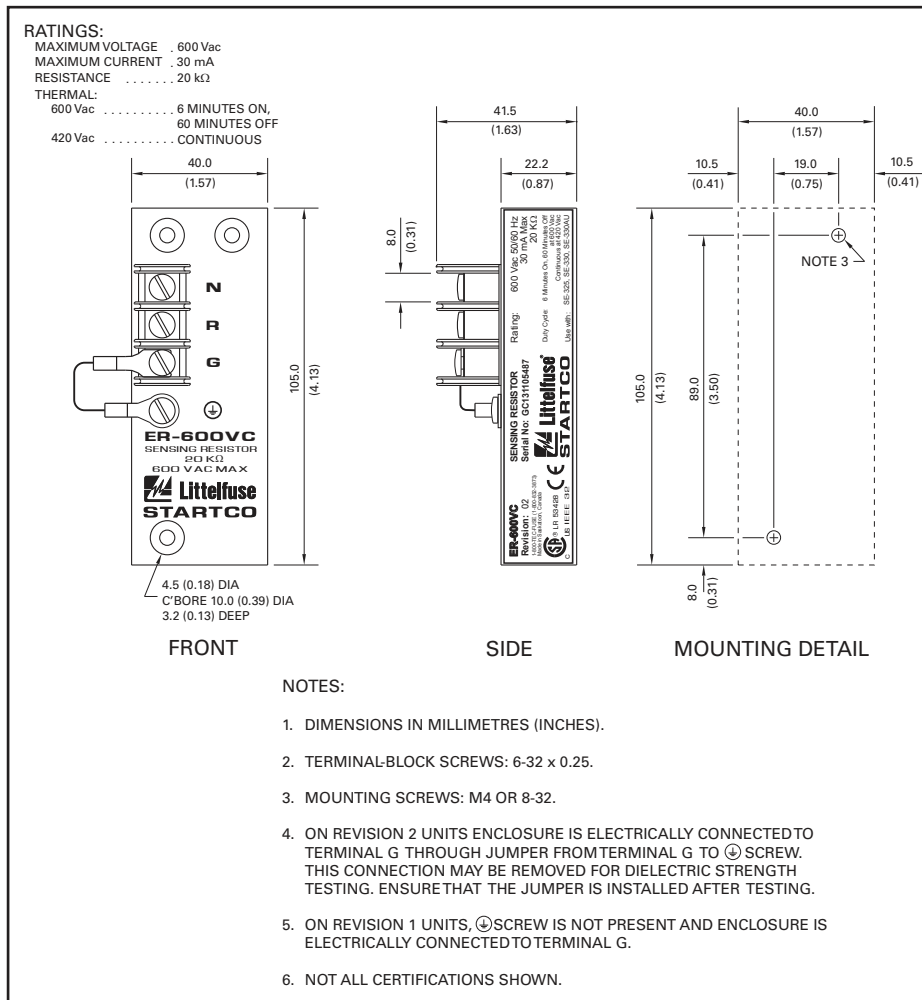

FIG. 8. ER-600VC sensing resistor.

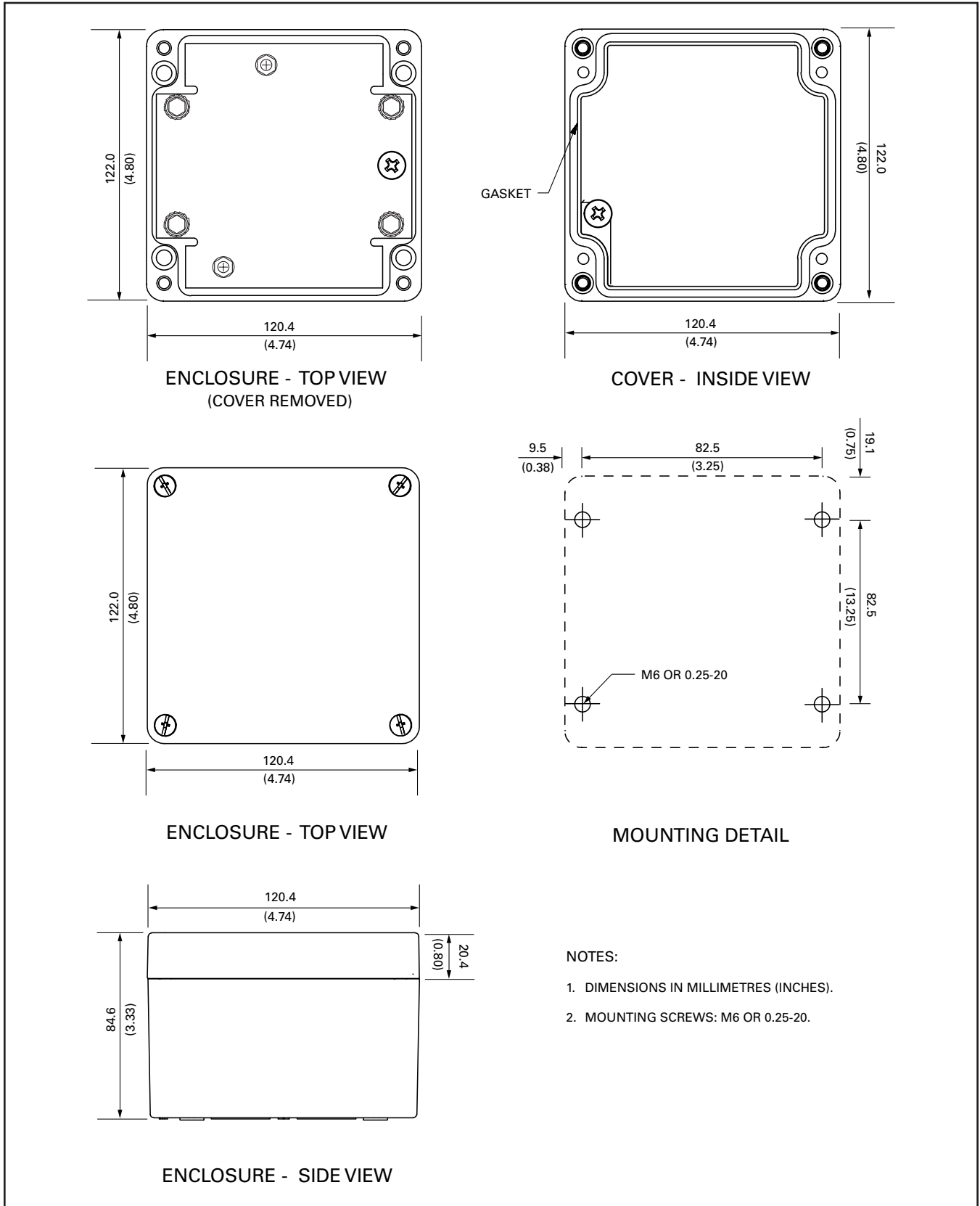

FIG. 9. SE-MRE-600 moisture-resistant enclosure outline.

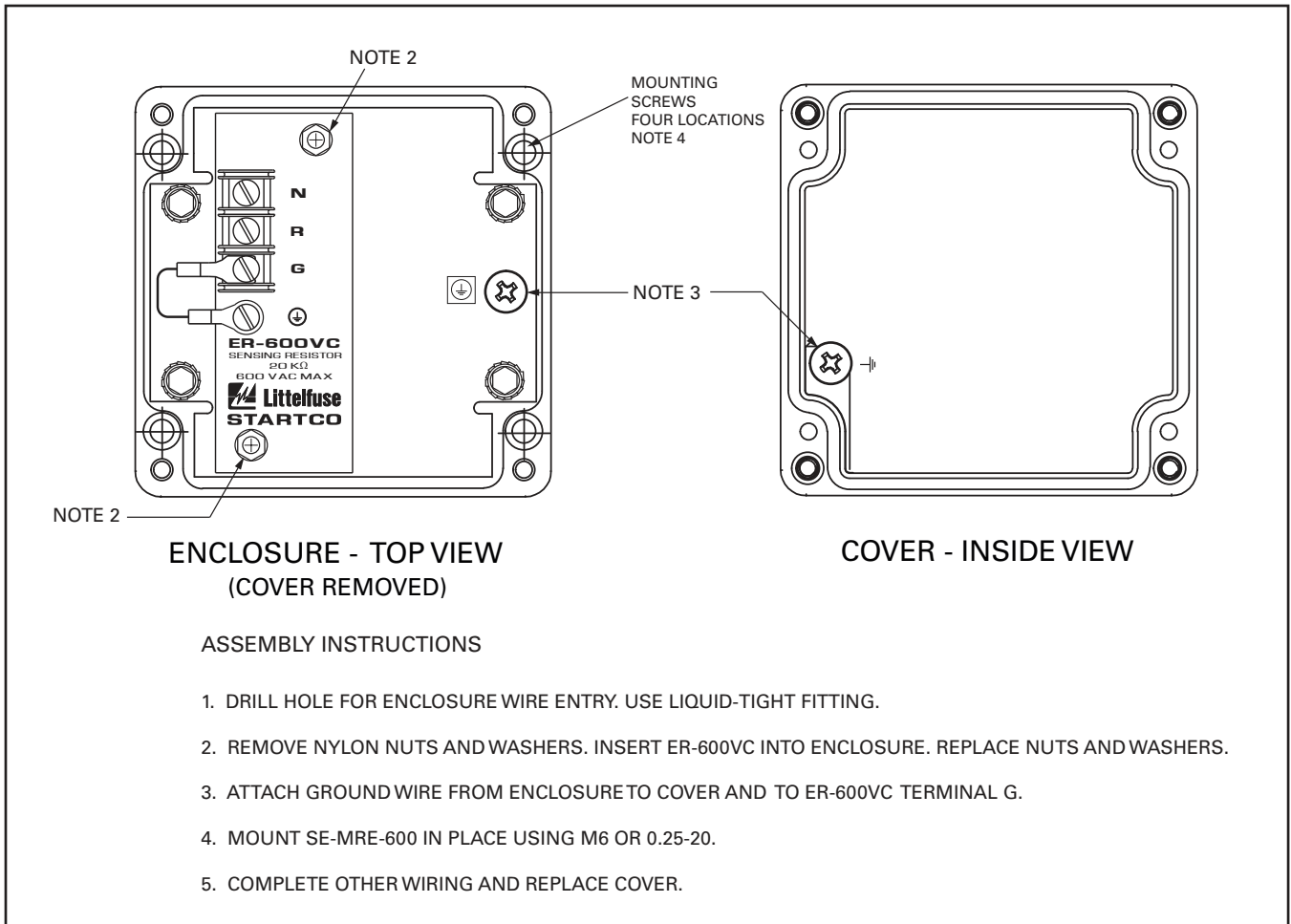
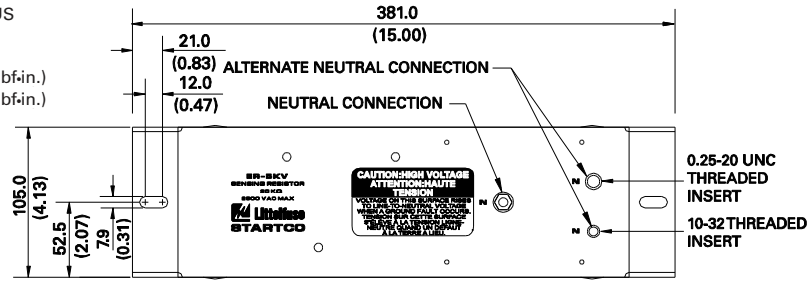

FIG. 10. ER-600VC installed in SE-MRE-600.

RATINGS:

MAXIMUM VOLTAGE . . . 2,500 Vac
 MAXIMUM CURRENT. 125 mA
 RESISTANCE 20 kΩ
 THERMAL CONTINUOUS
 TORQUE
 TERMINAL N (3 LOCATIONS)
 10-32 INSERT. 5.6 N-m (50 lbf-in.)
 OTHERS 9.0 N-m (80 lbf-in.)



TOP VIEW

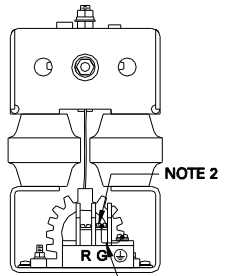

SIDE VIEW

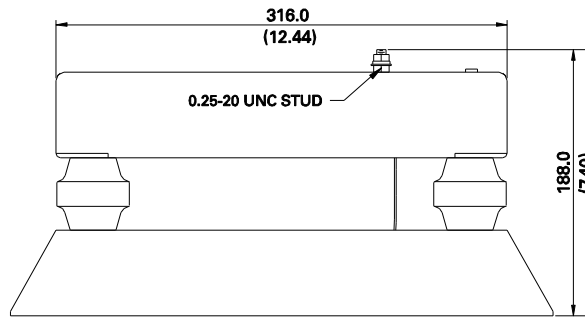

FRONT VIEW

NOTES:

1. DIMENSIONS IN MILLIMETRES (INCHES).
2. TERMINAL-BLOCK SCREWS: 6-32 x 0.25.
3. MOUNTING SCREWS: M6 OR 0.25-20.
4. THIS DEVICE CAN DISSIPATE 300 WATTS. TO MINIMIZE SURFACE TEMPERATURES FOR SYSTEMS ALLOWED TO OPERATE CONTINUOUSLY WITH A GROUND FAULT, MOUNT VERTICALLY WITH R & G TERMINALS DOWN.
5. ON REVISION 2 UNITS BASE IS ELECTRICALLY CONNECTED TO TERMINAL G THROUGH JUMPER FROM TERMINAL G TO ⊕ SCREW. THIS CONNECTION MAY BE REMOVED FOR DIELECTRIC STRENGTH TESTING. ENSURE THAT THE JUMPER IS INSTALLED AFTER TESTING.
6. ON REVISION 0 & 1 UNITS ⊕ SCREW IS NOT PRESENT AND BASE IS ELECTRICALLY CONNECTED TO TERMINAL G.
7. CERTIFICATIONS NOT SHOWN.

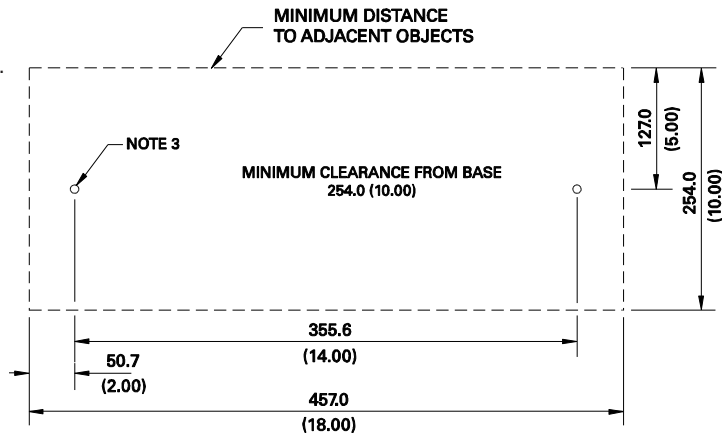

MOUNTING DETAIL

FIG. 11. ER-5KV sensing resistor.

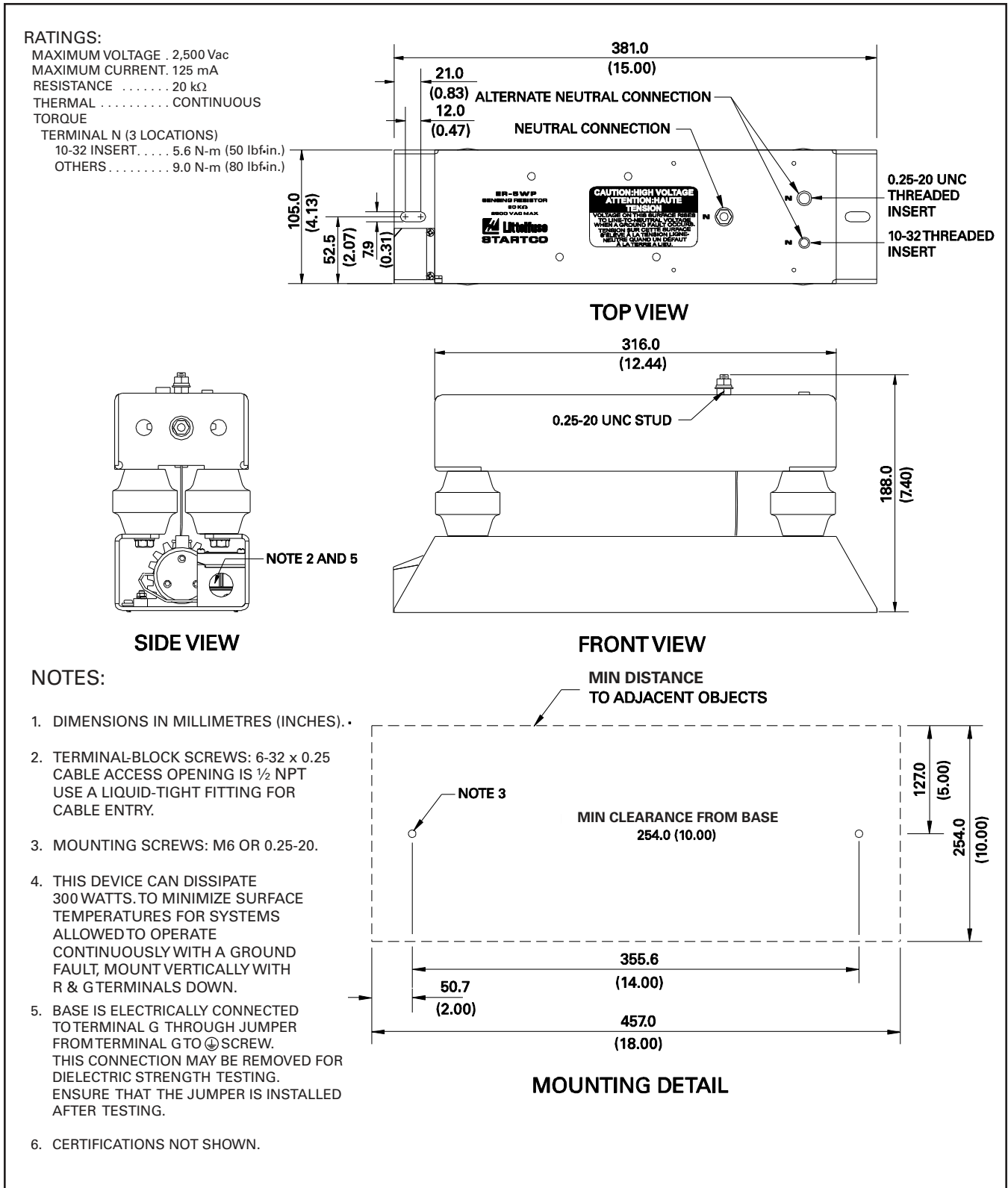

FIG. 12. ER-5WP sensing resistor.

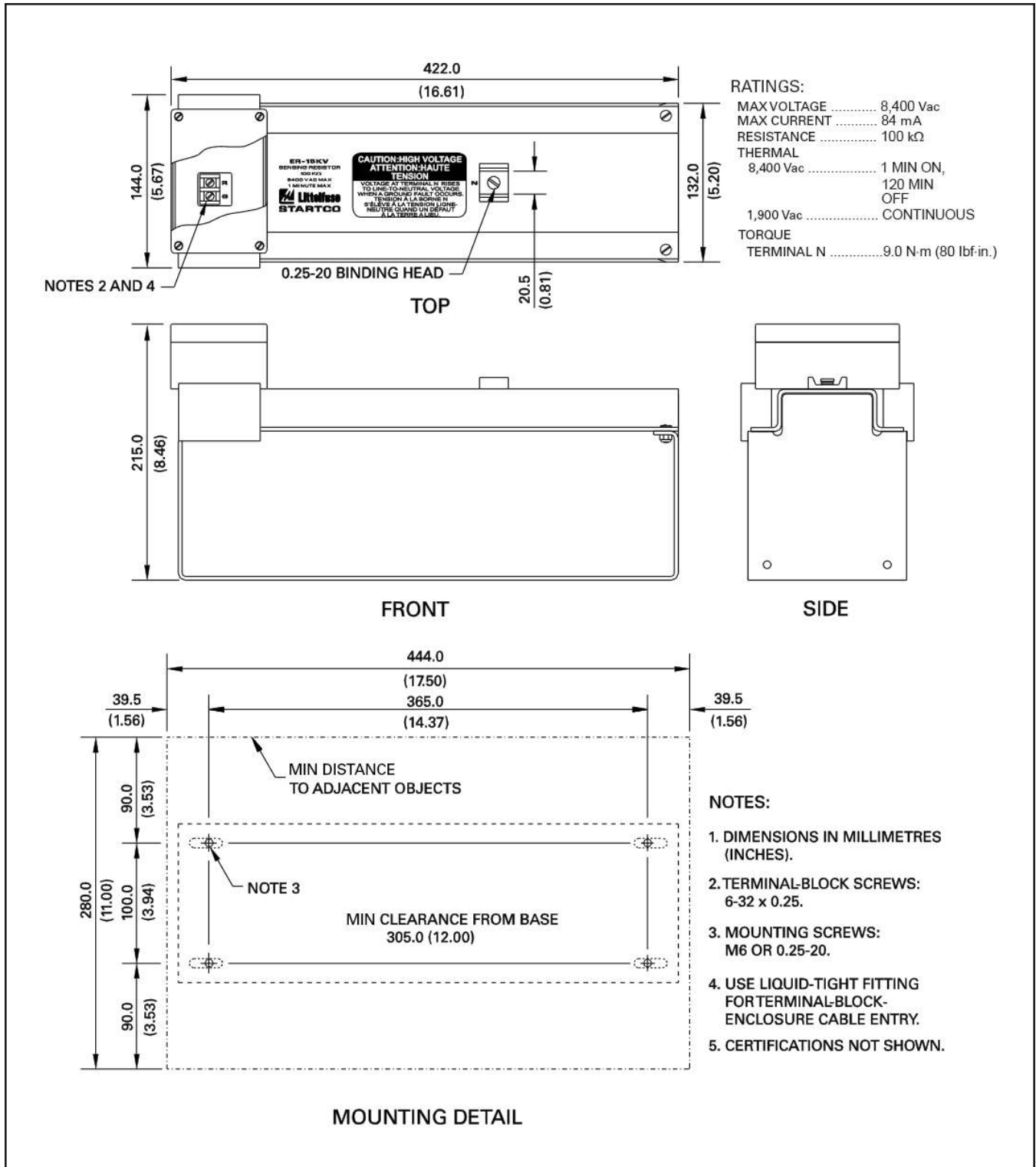

FIG. 13. ER-15KV sensing resistor.

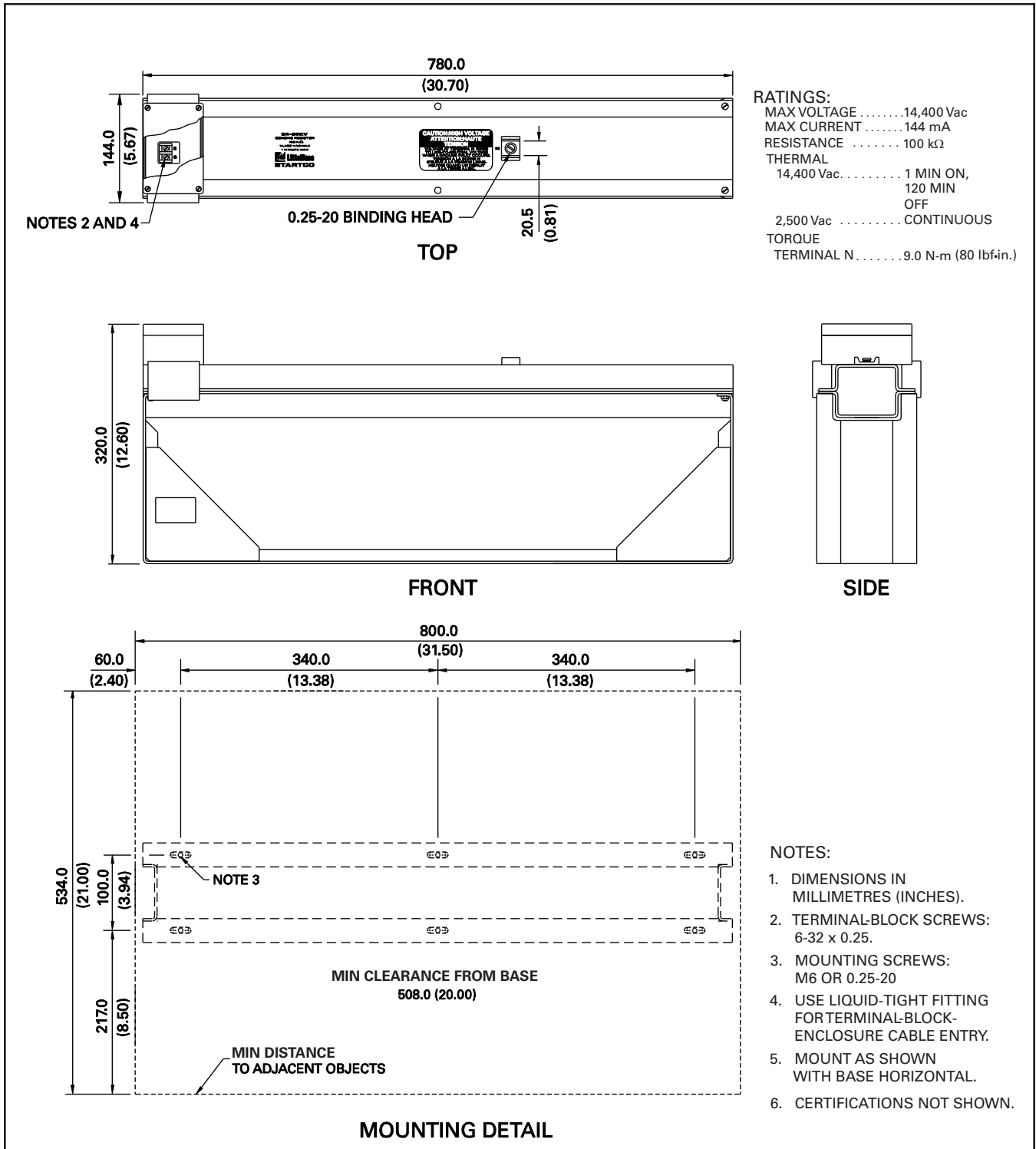

FIG. 14. ER-25KV sensing resistor.

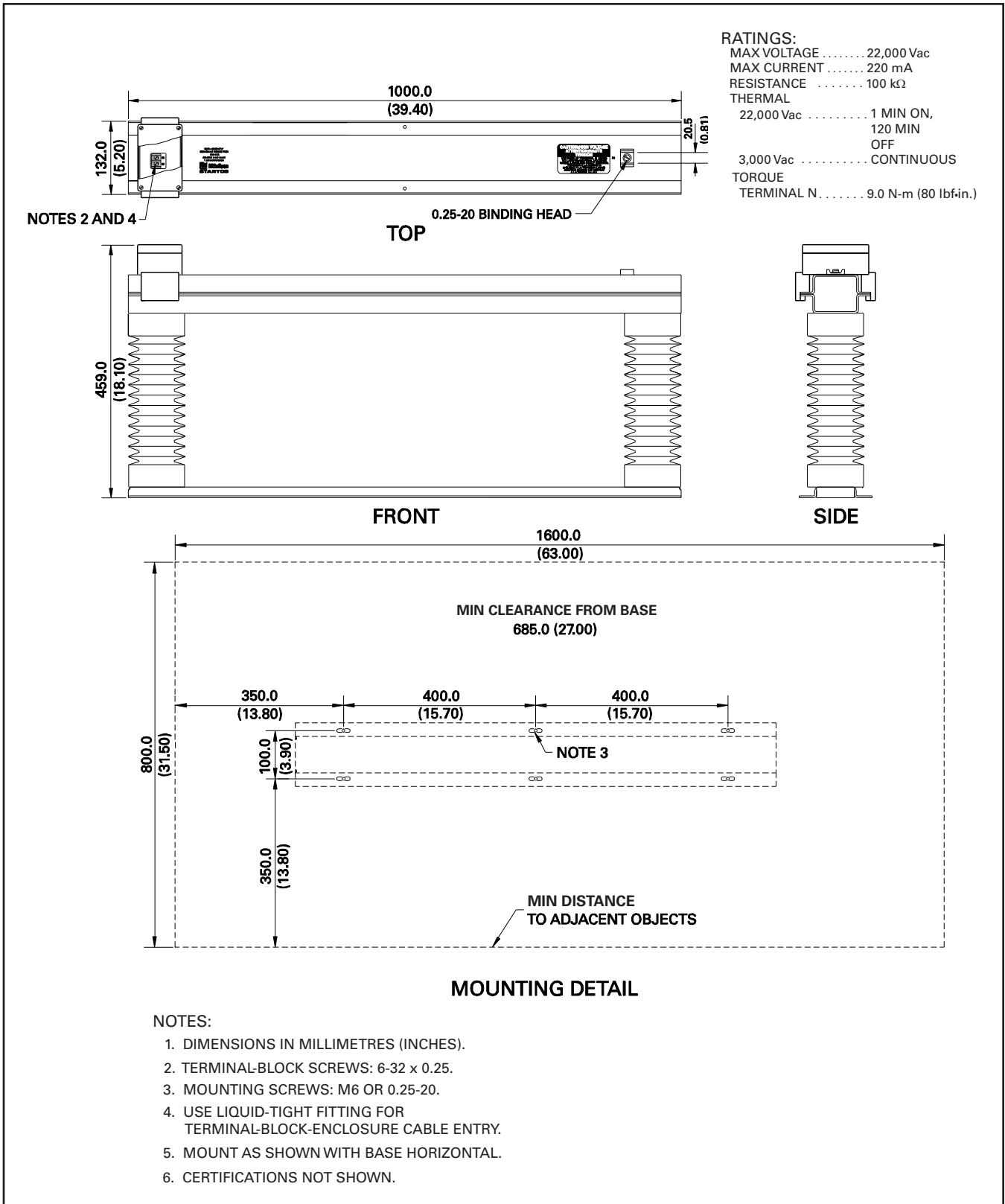

FIG. 15. ER-35KV sensing resistor.

3.3 Ground-Fault CT

Select and install a ground-fault CT that will provide the desired trip level. Typically, the CT-primary rating should be approximately equal to the NGR let-through-current rating. This provides an appropriate GF TRIP LEVEL setting range and analog-output scaling. See Sections 2.1.2 and 2.9.

The outline and mounting details for the ELCT5- and ELCT30-series current sensors are shown in Fig. 16 and Fig. 17. Ground-fault-CT connections and the typical ground-fault-CT location are shown in Fig. 3.

For SE-325 replacement applications, the existing CT200 current sensor will typically have to be replaced. However, where a replacement is not necessary or possible, the CT200 can be connected to either the 1- or 5-A input. This CT has a 200:5 current ratio. If connected to the 1-A input, the ground-fault trip level will be a percentage of 40 A. See Section 2.1.2.

The accuracy of a typical current sensor, including the CT200, will decrease when below 5% of its current rating. CT-primary current-injection testing is recommended to verify trip levels below 5% of the CT-primary rating. See Section 9.4. Littelfuse Startco current sensors with a 50-mA-secondary rating, such as the ELCT5-x and ELCT30-series, are designed for use at low levels and respond linearly to 2% current rating.

NOTE: The current-sensor insulation class is of no consequence if its secondary is grounded and the conductors through its window are insulated for the system voltage. Medium-voltage systems may require a bushing-type CT.

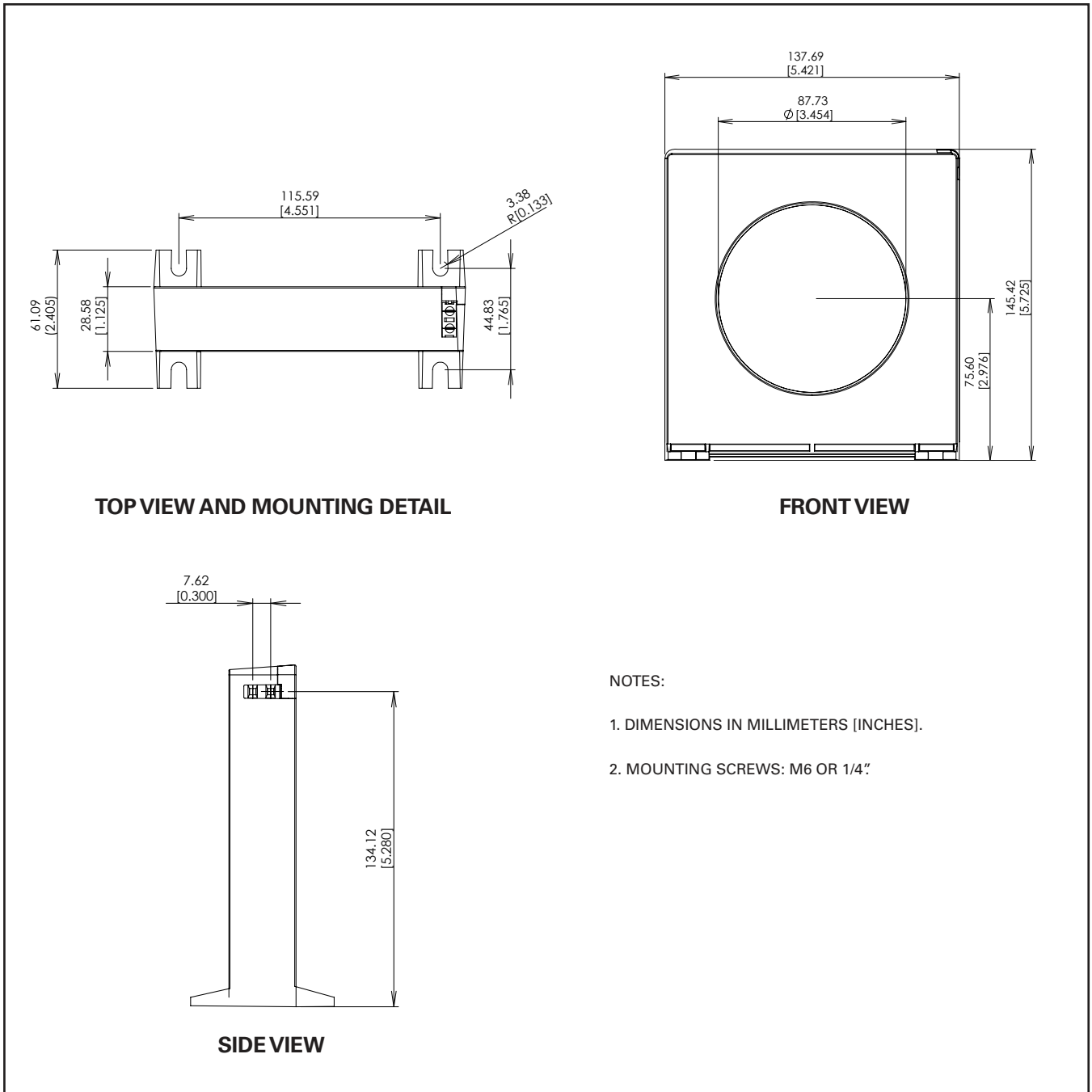

FIG. 16. ELCT5-88 and ELCT30-88 ground-fault current sensors.

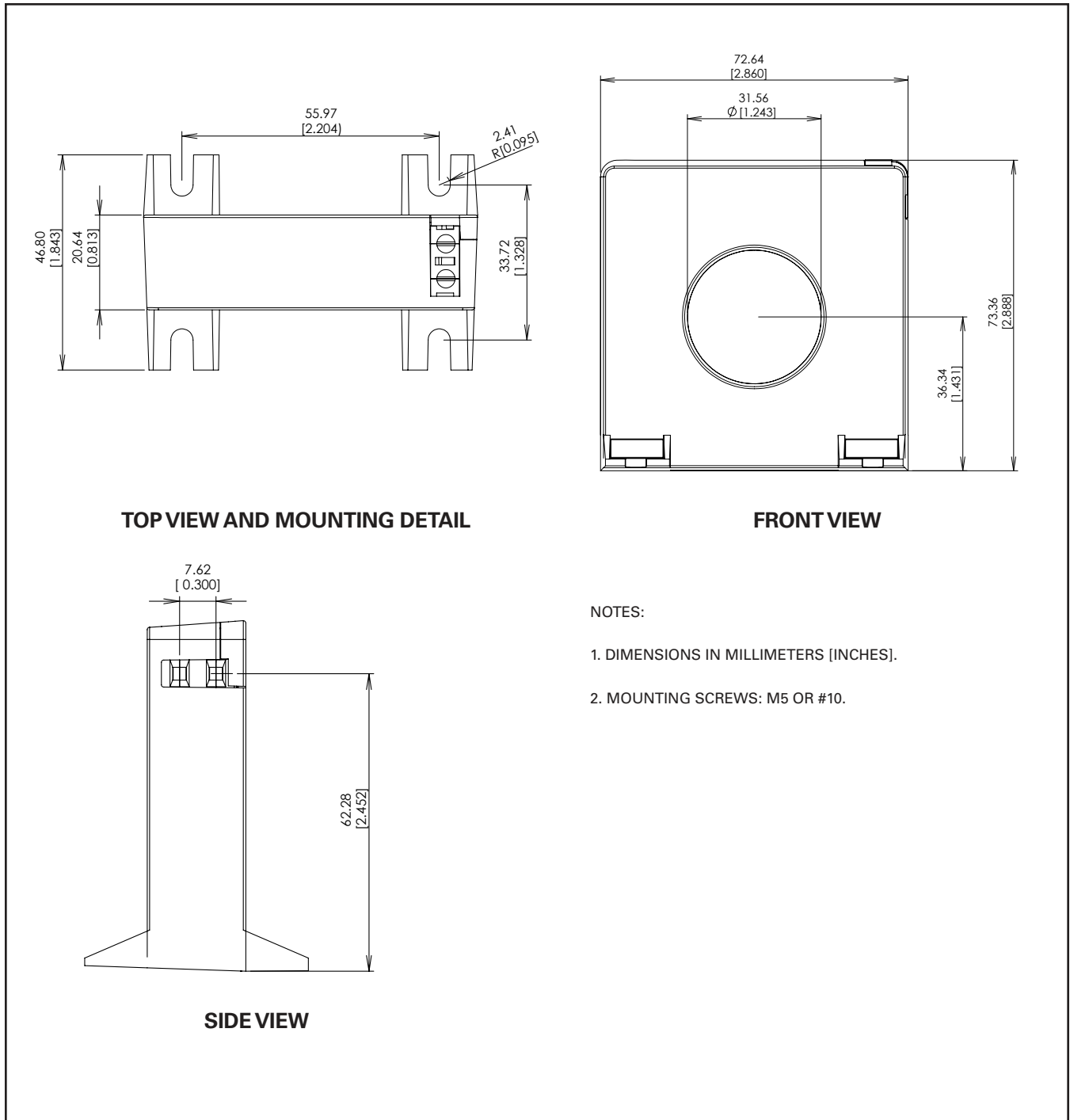

FIG. 17. ELCT5-31 and ELCT30-31 ground-fault current sensors.

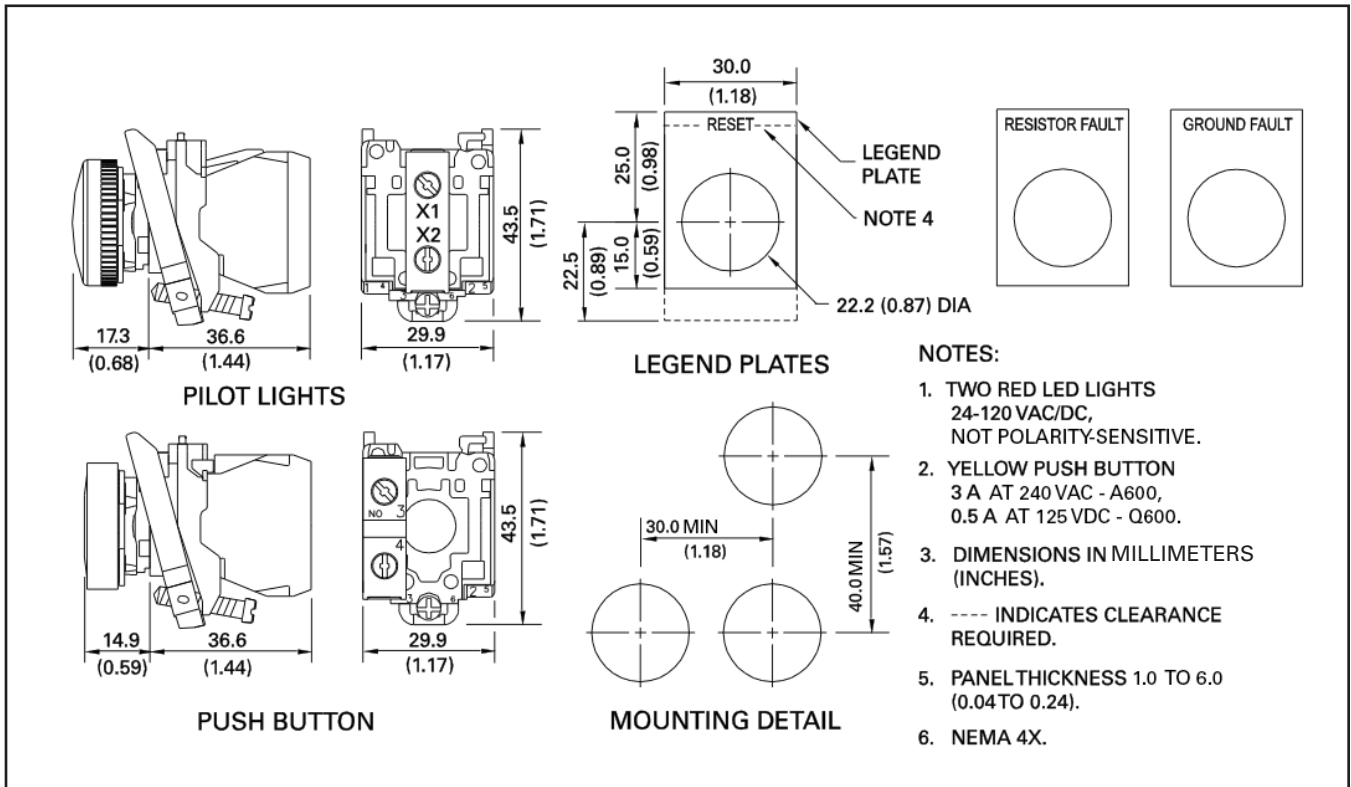

FIG. 18. RK-332 remote indication and reset.

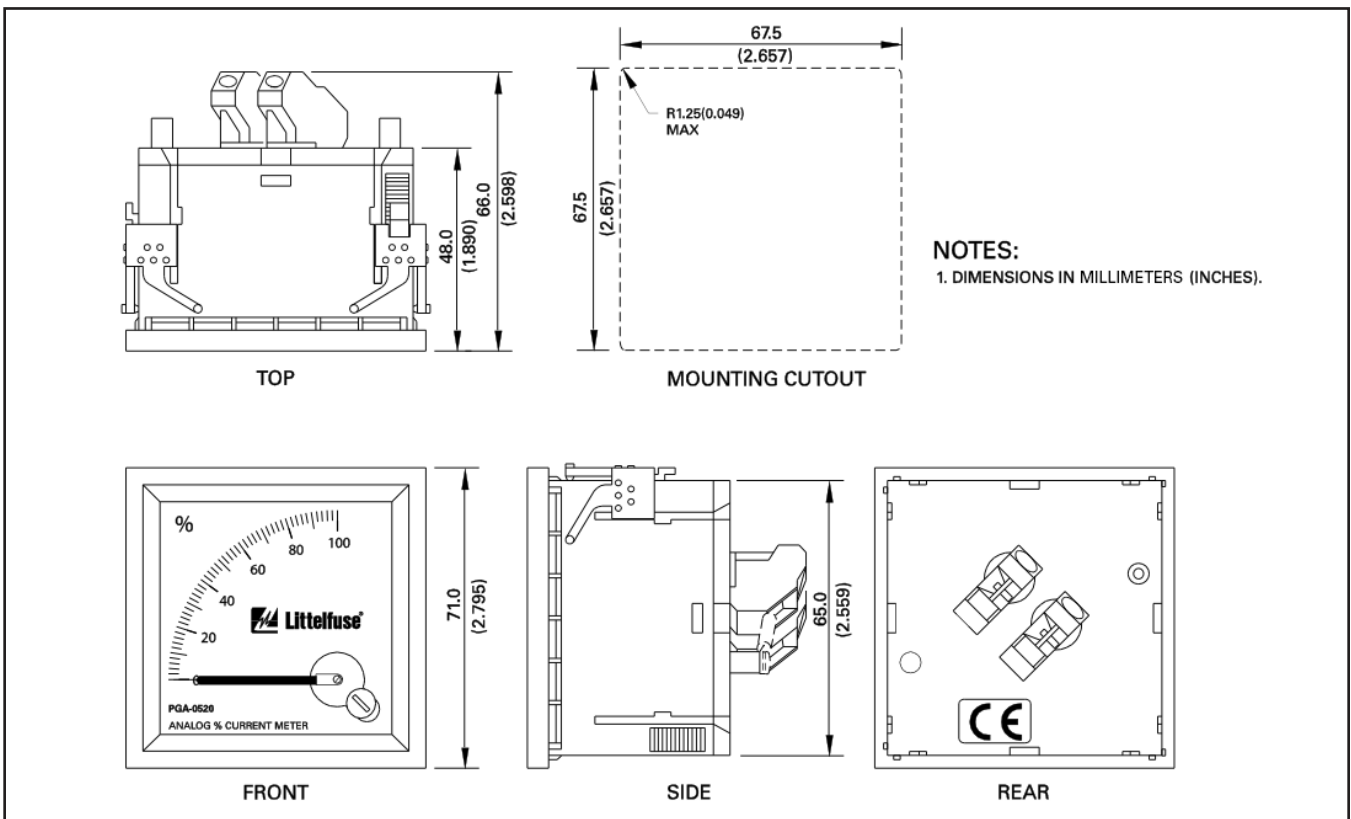

FIG. 19. PGA-0520 analog percent current meter.

4. DATA INTERFACES

4.1 SD Card

The SE-330 supports microSD data storage. The microSD card port is located on the front panel just below the USB port. The microSD card is used for short-term data logging of measured values and for firmware upgrades.

NOTE: SD card performance may vary by manufacturer, model, and with varying environmental conditions. The included microSD card has a temperature rating of -25 to 85°C (-13 to 140°F). For applications colder than -25°C (-13°F), use an industrial-grade microSD card.

NOTE: SD card usage is intended for use with the SE-330 only. Do not store other data on the SD card because files may be automatically deleted.

4.1.1 Datalogging

When a microSD card is installed, the SE-330 looks for a directory called "Datalogging." If this directory exists, data logging will automatically start after the card is indexed (indexing may take several minutes depending on the size of the card and the number of files).

The log is updated every two seconds and includes the measured values, configuration parameters, and trip status. A new log file is created at the start of each day. The most recent two months of log files are retained.

The red DIAGNOSTIC LED may indicate an SD Card error. See Sections 2.8 and 5. Approximately 500 MB of data is generated per month of logging.

4.1.2 FIRMWARE UPGRADE

Firmware upgrades are performed using a microSD card in conjunction with configuration switch S8. See Section 2.1.5.7. The SE-Flash software is not required.

To upgrade the SE-330 firmware, insert a microSD card containing the firmware upgrade file (.S19 format) in the root directory of the SD card and set switch S8 to UPGRADE within 30 seconds of card installation. If S8 is switched to UPGRADE after 30 seconds, the upgrade process will not occur. If the microSD card is inserted after S8 is switched to UPGRADE, switch S8 to RUN and then back to UPGRADE. The SE-330 evaluates firmware upgrade files found in the root directory of the microSD card and uses the first valid file.

Ensure that the DIAGNOSTIC LED is off before beginning the firmware upgrade process.

The red DIAGNOSTIC LED blinks rapidly while the firmware upgrade is running and the SE-330 may reset multiple times during the upgrade process. Do not remove the SD card or power off the SE-330 until the DIAGNOSTIC LED has stopped blinking rapidly for at least 30 seconds. If the upgrade is not successful, then the DIAGNOSTIC LED will indicate an SD upgrade error. See Section

5. Set switch S8 back to RUN for normal operation. If a firmware upgrade fails, then the existing firmware will not be overwritten.

A record of the upgrade can be found in "upgrade_log_<SN>.txt" on the microSD card. This file is updated each time an upgrade is performed.

NOTE: The maximum microSD card storage capacity is 32 GB for SE-330 hardware revision 16 and higher. The maximum microSD card storage capacity is 4 GB for SE-330 hardware revision 15 and lower.

4.2 USB Interface

Use the SE-MON330 software to access set-points, measured values, and trip records through the Mini-B USB interface located on the front panel. SE-MON330 version 4.0 or newer is required for some set-points. The following information can be viewed:

- Front-panel and configuration-switch settings
- Neutral voltage and neutral current
- Resistance change from the calibrated value
- Trip status
- Trip records, 100 date and time stamped
- Firmware version and serial number

The following values can be viewed and adjusted:

- Ground-fault trip setting (when front-panel GF trip level is set to MEM)
- K1, K2 and K3 relaying
- K2 ground-fault relay output operating mode
- K3 resistor-fault relay output operating mode
- NGR Short Detection (multiple settings)
- Clock settings
- Trip records can be cleared
- Remote calibration
- Resistor-fault trip time
- Resistor-fault trip level
- Geo-magnetic filter
- Critical and non-critical diagnostic codes

Ensure the real-time clock is set to the correct time prior to normal operation. Trip records and on-board datalogging information include date and time readings from the clock. Refer to the SE-MON330 software help file for further information.

NOTE: SE-330 hardware revisions 10 and later include an internal rechargeable battery that powers the real-time clock. Please consult local regulations regarding the use of batteries in electrical equipment. The SE-330 battery is not designed for user service or removal; please contact Littelfuse with any questions regarding battery removal.

4.3 Network Communications

The optional communications interfaces include a single CAN port and dual Ethernet ports supporting cable, fiber⁽¹⁾, or both cable and fiber. Protocols include:

- DeviceNet over CAN (ordering option 1)
- EtherNet/IP cable or fiber (ordering options 3, 4, and 5)
- Modbus TCP over cable or fiber (ordering options 3, 4, and 5)
- IEC 61850 over cable or fiber (ordering options 6, 7, and 8)

See Section 7 and refer to the appropriate SE-330 communications-interface manual for details.

⁽¹⁾ Uses the plug-in style SC connector.

5. TROUBLESHOOTING

PROBLEM	DIAGNOSTIC LED FLASH CODE ⁽¹⁾	SOLUTION
POWER LED off.		Check if supply voltage is present in terminals 1 and 2. If present, an overvoltage may have caused the power supply to shutdown. Cycle the supply voltage. If POWER LED remains off, consult Littelfuse.
POWER LED flashes.		A power-supply overload has occurred. Cycle supply voltage. If problem persists, consult Littelfuse.
Calibration-Error Trip DIAGNOSTIC LED flash code	1 L - 1 S - 1 L	The total resistance of the NGR and sensing-resistor circuit is outside the calibration range. Verify that switch S5 is set to match the resistance of the sensing resistor, check the resistance of the NGR, and verify the sensing-resistor circuit. See Section 9.2 for sensing-resistor tests. Repeat the calibration procedure after the open or shorted condition has been corrected. Critical diagnostic code. GF LED ⁽²⁾ : No Change; RF LED ⁽²⁾ : ON; Assigned Relay: Trip
Remote Trip DIAGNOSTIC LED flash code	1 L - 2 S - 1 L	The SE-330 was tripped by a signal from network communications. Press RESET to clear the trip. Critical diagnostic code. GF LED ⁽²⁾ : ON; RF LED ⁽²⁾ : ON; Assigned Relay: Trip
A/D-Converter-Error Trip DIAGNOSTIC LED flash code	1 L - 4 S - 1 L	An A/D-converter error was detected. Press RESET to clear the trip. If the problem persists, consult Littelfuse. Critical diagnostic code. GF LED ⁽²⁾ : No Change; RF LED ⁽²⁾ : ON; Assigned Relay: Trip
SD Card DIAGNOSTIC LED flash code	1 L - 5 S - 1 L	SD card is full or a write error occurred. Delete files or use a different microSD card. Non-critical diagnostic code. GF LED ⁽²⁾ : No Change; RF LED ⁽²⁾ : No Change; Assigned Relay: No Change If this diagnostic was caused during an attempt to upgrade the firmware, follow this alternative process: <ul style="list-style-type: none"> Remove supply from SE-330. Insert a microSD card containing the firmware upgrade file in the root directory of the SD card. Power on the SE-330. Set switch S8 to UPGRADE within 30 seconds of startup. The upgrade should continue as described in Section 4.1.2.
Watchdog Trip DIAGNOSTIC LED flash code	1 L - 6 S - 1 L	A watchdog trip results in a processor reset. During reset, UNIT HEALTHY relay K4 will be de-energized. After a reset, UNIT HEALTHY relay K4 will be energized. Press RESET to clear the trip. If the problem persists, consult Littelfuse. Critical diagnostic code. GF LED ⁽²⁾ : ON; RF LED ⁽²⁾ : ON; Assigned Relay: Trip
Non-Volatile Memory Error Trip DIAGNOSTIC LED flash code	1 L - 8 S - 1 L	An error was detected in the non-volatile memory. Press RESET to clear the trip. If the problem persists, consult Littelfuse. Critical diagnostic code. GF LED ⁽²⁾ : ON; RF LED ⁽²⁾ : ON; Assigned Relay: Trip
SD Upgrade Error DIAGNOSTIC LED flash code	1 L - 9 S - 1 L	An error occurred during the flash-memory upgrade procedure. Ensure that the firmware upgrade file is correct or use a different microSD card. Critical diagnostic code. GF LED ⁽²⁾ : No Change; RF LED ⁽²⁾ : No Change; Assigned Relay: No Change

PROBLEM	DIAGNOSTIC LED FLASH CODE ⁽¹⁾	SOLUTION
USB Error DIAGNOSTIC LED flash code	1 L - 10 S – 1 L	A USB algorithm timeout has been detected. Remove and reconnect the USB cable and cycle supply voltage. If the problem persists, consult Littelfuse. Non-critical diagnostic code. GF LED ⁽²⁾ : No Change; RF LED ⁽²⁾ : No Change; Assigned Relay: No Change
DIAGNOSTIC LED = solid red		SE-330 processor failed to start. Cycle supply. If problem persists, consult Littelfuse. K1: De-energized.
Pressing RESET does not clear trips.		Trip condition is still present. Locate and correct. The RESET button is disabled if remote-reset terminals 15 and 16 are connected. Replace shorted remote-reset switch or issue Reset command from the communications network.
UNIT HEALTHY relay K4 momentarily changes state		Processor has been reset.
No analog-output current.		The output at terminals 19 and 20 requires a voltage source. See Fig. 2 for analog-output connections. See Section 9.3 for the analog-output tests.

NOTES:
⁽¹⁾ L = long pause, S = short flash.

⁽²⁾ When LED is on, corresponding indication relay is energized when in the non-fail-safe mode or de-energized when in the fail-safe mode.

6. TECHNICAL SPECIFICATIONS

6.1 SE-330

Supply:

Option 0.....	30 VA, 120 to 240 Vac (+10, -45%), 50/60 Hz; 20 W, 110 to 250 Vdc (+10, -25%)
Option 2.....	20 W, 48 Vdc (+50, -25%); 35 VA, 48 Vac (+10, -45%), 50/60 Hz

Power-Up Time..... 3 s at 120 Vac

AC Measurements Discrete Fourier Transform. 16 samples per cycle, 50 or 60 Hz

Resistor-Fault Circuit:

Neutral-To-Ground Voltage Trip Levels⁽¹⁾:

ER-600VC or ER-5KV.....	20; 60; 100; 130; 170; 200; 340; 800; 1,200; 1,700; 2,000 Vac
ER-15KV to ER-35KV.....	100; 300; 500; 650; 850; 1,000; 1,700; 4,000; 6,000; 8,500; 10,000 Vac

Accuracy 10% of setting

3 dB Frequency Response:

S6 = 50 Hz.....	25 to 85 Hz
S6 = 60 Hz.....	30 to 90 Hz

NGR Calibration Range:

ER-600VC, ER-5KV, or ER-5WP.....	0 to 2 kΩ
ER-15KV to ER-35KV.....	0 to 10 kΩ

Trip Resistance, $V_N = 0$:

ER-600VC, ER-5KV, or ER-5WP:	
Range ⁽⁵⁾	250 to 750-Ω change ± 200 Ω
Default.....	500-Ω change
ER-15KV to ER-35KV:	
Range ⁽⁵⁾	1.25 to 3.75-kΩ change ± 1 kΩ
Default.....	2.5-kΩ change

Neutral-To-Ground DC-Voltage Rejection:

ER-600VC, ER-5KV, or ER-5WP.....	25 Vdc
ER-15KV to ER-35KV.....	125 Vdc

Trip Time..... 12 to 60 s ± 1 s

Trip Hold-Off Level 5% of CT-primary rating

Trip Mode Latching/non-latching

NGR Short Detection:

Nominal NGR Resistance 15 to 2,000 Ω, 166 Ω
min for 100 kΩ
sensing resistors

NGR Short Trip Level..... 10 to 70% of the nominal
NGR resistance

NGR Short Mode..... Monitor only, monitor and
trip, disabled

Accuracy:

ER-600VC, ER-5KV, ER-5WP:

0 to 40°C	±5 Ω typical, ±10 Ω max
-40 to 60°C	±12 Ω typical, ±20 Ω max

ER-15KV, ER-25KV, ER-35KV:

0 to 40°C	±30 Ω typical, ±50 Ω max
-40 to 60°C	±60 Ω typical, ±100 Ω max

Optimum Calibration

Temperature..... Midpoint of local/installed
temperature range

Ground-Fault Circuit:

Trip Level..... 2, 4, 6, 8, 10, 20, 40, 60,
80, 100% of CT-primary
rating or 2 to 100% using
MEM parameter

Trip Time..... 0.1, 0.2, 0.3, 0.4, 0.5, 0.7,
1.0, 2.0, 3.0, 5.0, 10.0 s

Trip-Level Accuracy:

EFCT-x, CS30-x..... max of 1% of CT-primary
rating or 3% of setting⁽²⁾

ELCT5-x, ELCT30-x..... max of 1% of CT-primary
rating or 5% of setting⁽²⁾

Trip-Time Accuracy..... 10% of setting, 20 ms
min

3 dB Frequency Response:

S6 = 50 Hz	25 to 85 Hz
S6 = 60 Hz	30 to 90 Hz

Maximum CT lead resistance:

ELCT5 & ELCT30.....	5 Ω
Other CTs.....	Consult CT curve

CT-Input Burden:

5-A Input	< 0.01 Ω
1-A Input	< 0.05 Ω
EFCT Input	< 10 Ω

Thermal Withstand:

1-A and 5-A Inputs:	
Continuous.....	2 x CT rating
1-Second.....	20 x CT rating

EFCT Input:

Continuous.....	10 x CT rating
1-Second.....	25 x CT rating

Measurement Range 25 x CT-primary rating

Trip Mode Latching/non-latching

Pulsing Circuit:

Pulse Period 1.0 to 3.0 s,
0.2-s increments

Duty Cycle	50%	Range.....	4 to 22 mA
Time Accuracy.....	10% of setting	Loop Voltage.....	8 to 36 Vdc
Trip/Pulsing Relay K1 Contacts:		Load	500 Ω (max with 24-Vdc supply)
Configuration.....	N.O. (Form A)	Isolation.....	120 Vac
Operating Mode.....	Fail-safe or non-fail-safe	Parameter	NGR current, 20 mA = CT primary current
CSA/UL Contact Ratings.....	8 A resistive 250 Vac, 5 A resistive 30 Vdc		
Supplemental Contact Ratings:		USB Communications:	
Make/Carry 0.2 s.....	30 A	Baud Rate	12 Mbit/s
Break:		Protocol.....	USB Device
dc.....	75 W resistive 35 W inductive (L/R = 0.004 s)	Connector	Mini-B
ac.....	2,000 VA resistive 1,500 VA inductive (PF = 0.4)	SD Memory Card:	
Subject to maxima of 8 A at 250 Vac, 8 A resistive at 30 Vdc, and 0.4 A resistive at 150 Vdc.		Type.....	Standard grade
		Form Factor	microSD ⁽³⁾ and microSDHC ⁽³⁾
		Format.....	FAT32
		Capacity:	
		SE-330 Hardware	
		Revision 16 and higher.....	512 MB to 32 GB
		SE-330 Hardware	
		Revision 15 and lower.....	512 MB to 4 GB
GF (K2) and RF (K3) Relay Contacts:		Operating Temperature:	
Configuration	N.O. and N.C. (Form C)	Standard Grade	
Operating Mode (5).....	Non-fail-safe or fail-safe	(Included).....	-25 to 85°C (-13 to 140°F)
CSA/UL Contact Ratings.....	8 A resistive 250 Vac 8 A resistive 30 Vdc	Industrial Grade.....	-40 to 85°C (-40 to 140°F)
Supplemental Contact Ratings:		Real-Time Clock:	
Make/Carry 0.2 s.....	30 A	Power-Off Operation	approx. 6 months at 20°C (68°F)
Break:		Battery included only in hardware revision 10 and higher.	
dc.....	75 W resistive 35 W inductive (L/R = 0.004 s)	Terminal-Block Ratings	10 A, 300 Vac, 12 AWG (2.5 mm ²)
ac.....	2,000 VA resistive 1,500 VA inductive (PF = 0.4)	PWB Conformal Coating	MIL-1-46058 qualified, UL QMJU2 recognized
Subject to maxima of 8 A at 250 Vac, 8 A resistive at 30 Vdc, and 0.4 A resistive at 150 Vdc.		Mounting Configurations	Panel mount and optional Surface mount
		Dimensions:	
		Height.....	213 mm (8.4 in.)
		Width	99 mm (3.9 in.)
		Depth.....	132 mm (5.2 in.)
Unit Healthy Output K4 (Option 0):		Shipping Weight	2.0 kg (4.4 lb)
Configuration	N.O. (Form A)	Environment:	
Operating Mode.....	Closed when healthy	Operating Temperature.....	-40 to 60°C (-40 to 140°F)
Ratings.....	100 mA, 250 V (ac or dc)	Storage Temperature	-55 to 80°C (-67 to 176°F)
Closed Resistance	30 to 50 Ω	Humidity	85% Non-condensing
		IP Rating.....	IP30
Unit Healthy Output K4 (Option 1):		Surge Withstand	ANSI/IEEE C37.90.1-1989 (Oscillatory and fast transient)
Configuration	N.C. (Form B)		
Operating Mode	Open when healthy		
Ratings.....	100 mA, 250 V (ac or dc)		
Closed Resistance	25 to 50 Ω		
Auto-reset time	2.8 s max		
4-20-mA Analog Output:			
Type.....	Self-powered and Loop-powered		

EMC Tests:

Verification tested in accordance with IEC 60255-26:2013.

Radiated and Conducted Emissions CISPR 11:2009, CISPR 22:2008, EN 55022:2010 Class A

Current Harmonics and Voltage Fluctuations IEC 61000-3-2 and IEC 61000-3-3 Class A

Electrostatic Discharge IEC 61000-4-2
± 6 kV contact discharge (direct and indirect)
± 8 kV air discharge

Radiated RF Immunity IEC 61000-4-3
10 V/m, 80-1,000 MHz, 80% AM (1 kHz)
10 V/m, 1.0 to 2.7 GHz, 80% AM (1 kHz)

Fast Transient IEC 61000-4-4
Zone B
± 2 kV (power supply port), ± 1 kV (all other ports)

Surge Immunity IEC 61000-4-5
Zone B
± 1 kV differential mode
± 2 kV common mode

Conducted RF Immunity IEC 61000-4-6
10 V, 0.15-80 MHz, 80% AM (1 kHz)

Magnetic Field Immunity IEC 61000-4-8
50 Hz and 60 Hz
30 A/m and 300 A/m

Power Frequency⁽⁴⁾ IEC 61000-4-16
Zone A: differential mode
100 Vrms
Zone A: common mode
300 Vrms

1 MHz Burst IEC 61000-4-18
± 1 kV differential mode (line-to-line)
± 2.5 kV common mode

Voltage Interruption IEC 61000-4-11, IEC 61000-4-29
0% for 10, 20, 30, 50 ms (dc)
0% for 0.5, 1, 2.5, 5 cycles (60 Hz)
IEC 61000-4-17
Level 4, 15% of the rated dc value

Certification CSA, Canada and United States



UL Listed



Australia



CE, European Union



FCC



To: CSA C22.2 No. 14 Industrial Control Equipment
UL 508 Industrial Control Equipment
UL 1053 Ground Fault Sensing and Relaying Equipment
Australia, Regulatory Compliance Mark (RCM)
CE Low Voltage Directive
IEC 61010-1:2010 (3rd Edition) + AMD 1:2016
FCC CFR47, Part 15, Subpart B,
Class A – Unintentional Radiators

Compliance RoHS Compliant

NOTES:

- (1) See sensing resistor specifications for applicable voltage limits.
- (2) Accuracy included for EFCT-x, SE-CS30-x, ELCT5-x, and ELCT30-x current sensors only.
- (3) microSD and microSDHC are trademarks of SD-3C, LLC.
- (4) Remote-reset and pulse-enable wiring is limited to 10 m (32 ft).
- (5) This value can only be modified using SE-MON330 software. See Section 4.2.

6.2 Sensing Resistors

Environment:

Operating Temperature -40 to 60°C (-40 to 140°F)
Storage Temperature -55 to 80°C (-67 to 176°F)
Extended Operating Temperature -55 to 60°C (-67 to 140°F)⁽¹⁾

ER-600VC:

Maximum Voltage	600 Vac
Maximum Current	30 mA
Resistance	20 kΩ
Thermal:	
420 Vac	Continuous
600 Vac	6 minutes on, 60 minutes off
Shipping Weight	300 g (0.7 lb)

ER-5KV:

Maximum Voltage	2,500 Vac
Maximum Current	125 mA
Resistance	20 kΩ
Thermal	Continuous
Torque:	
Terminal N:	
10-32 Insert	5.6 N•m (50 lbf•in.)
Others	9.0 N•m (80 lbf•in.)
Shipping Weight	5.0 kg (11 lb)

ER-5WP:

Maximum Voltage	2,500 Vac
Maximum Current	125 mA
Resistance	20 kΩ
Thermal	Continuous
Torque:	
Terminal N:	
10-32 Insert	5.6 N•m (50 lbf•in.)
Others	9.0 N•m (80 lbf•in.)
Shipping Weight	5.0 kg (11 lb)

ER-15KV:

Maximum Voltage	8,400 Vac
Maximum Current	84 mA
Resistance	100 kΩ
Thermal:	
8,400 Vac	1 minute on, 120 minutes off
1,900 Vac	Continuous
Torque (Terminal N)	9.0 N•m (80 lbf•in.)
Shipping Weight	5.0 kg (11 lb)

ER-25KV:

Maximum Voltage	14,400 Vac
Maximum Current	144 mA
Resistance	100 kΩ
Thermal:	
14,400 Vac	1 minute on, 120 minutes off
2,500 Vac	Continuous
Torque (Terminal N)	9.0 N•m (80 lbf•in.)
Shipping Weight	20 kg (44 lb)

ER-35KV:

Maximum Voltage	22,000 Vac
Maximum Current	220 mA
Resistance	100 kΩ
Thermal:	
22,000 Vac	1 minute on, 120 minutes off
3,000 Vac	Continuous
Torque (Terminal N)	9.0 N•m (80 lbf•in.)
Shipping Weight	40 kg (88 lb)

Certification CSA, Canada and United States



UL Listed



Australia



CE, European Union

NOTES:
⁽¹⁾ Electrical specifications have been verified at a Littelfuse lab.

6.3 Current Sensors
Environment:

Operating Temperature	-40 to 60°C (-40 to 140°F)
Storage Temperature	-55 to 80°C (-67 to 176°F)
Compliance	RoHS, IEC 61869-2 ANSI/IEEE C57.13

EFCT-1:

Current Ratio	5:0.05 A
Insulation	600-V Class
Window Diameter	82 mm (3.2")
Shipping Weight	0.9 kg (2.0 lb)
Certifications	CSA, UL, CE
Compliance	RoHS, IEC 60044-1
Extended Operating Temperature	-55 to 60°C (-67 to 140°F) ⁽¹⁾

Supplemental
Specifications:
Trip Level Accuracy:

≤ 1 A	1% of CT-Primary Rating
> 1 A	3% of CT-Primary Rating

EFCT-26:

Current Ratio 5:0.05 A
 Insulation 600-V Class
 Window Diameter 26 mm (1.0")
 Shipping Weight 0.45 kg (1.0 lb)
 Certifications CSA, UL, CE
 Compliance RoHS, IEC 60044-1
 Extended Operating
 Temperature -55 to 60°C (-67 to
 140°F)⁽¹⁾

 Supplemental
 Specifications:

Trip Level Accuracy:

≤ 1 A 1% of CT-Primary Rating
 > 1 A 3% of CT-Primary Rating

ELCT30-31:

Current Ratio 30:0.05 A
 Insulation 600-V Class
 Window Diameter 31 mm (1.22 in.)
 Shipping Weight 0.45 kg (1 lb)
 Certifications cUL, CE

ELCT30-88:

Current Ratio 30:0.05 A
 Insulation 600-V Class
 Window Diameter 88 mm (3.46 in.)
 Shipping Weight 0.91 kg (2 lb)
 Certifications cUL, CE

ELCT5-31:

Current Ratio 5:0.05 A
 Insulation 600-V Class
 Window Diameter 31 mm (1.22 in.)
 Shipping Weight 0.45 kg (1 lb)
 Certifications cUL, CE

ELCT5-88:

Current Ratio 5:0.05 A
 Insulation 600-V Class
 Window Diameter 88 mm (3.46 in.)
 Shipping Weight 0.91 kg (2 lb)
 Certifications cUL, CE

CT200:

Current Ratio 200:5 A
 Insulation 600-V Class
 Window Diameter 56 mm (2.2 in.)
 Shipping Weight 1 kg (2.2 lb)
 Certifications CSA, UL
 Compliance RoHS

Extended Operating

Temperature -55 to 60°C (-67 to
 140°F)⁽¹⁾

SE-CS30-26:

Current Ratio 30:0.05 A
 Insulation 600-V Class
 Window Diameter 26 mm (1.0")
 Shipping Weight 0.45 kg (1.0 lb)
 Certifications CSA, UL, CE
 Compliance RoHS, IEC 60044-1
 Extended Operating
 Temperature -55 to 60°C (-67 to
 140°F)⁽¹⁾

SE-CS30-70:

Current Ratio 30:0.05 A
 Insulation 600-V Class
 Window Diameter 70 mm (2.7")
 Shipping Weight 1.2 kg (2.5 lb)
 Certifications CSA, UL, CE
 Compliance RoHS, IEC 60044-1
 Extended Operating
 Temperature -55 to 60°C (-67 to
 140°F)⁽¹⁾

⁽¹⁾ Electrical specifications have been verified at a Littelfuse lab.

7. ORDERING INFORMATION

SE-330-	
	K4 Contact: 0 N.O. UNIT HEALTHY Contact 1 N.C. UNIT HEALTHY Contact
	Options: 0 No Options
	Network Communications:⁽¹⁾ 0 None 1 DeviceNet 3 Ethernet (Dual RJ45) ⁽²⁾ 4 Ethernet (SC fiber & RJ45) ⁽²⁾ 5 Ethernet (Dual SC fiber) ⁽²⁾ 6 IEC 61850 (Dual RJ45) 7 IEC 61850 (SC fiber & RJ45) 8 IEC 61850 (Dual SC fiber)
	Supply: 0 Universal ac/dc supply 2 48 Vdc supply

NOTE: Please refer to the SE-330 Product Change Notice (PCN) document for updated ordering information and new revision details, available at www.littelfuse.com/se-330.

NOTE: The SE-330-SMA surface mount adapter is available as an accessory only.

Sensing Resistors:

ER-600VC	For system voltages up to 1 kVac
ER-5KV	For system voltages up to 5 kVac
ER-5WP	For system voltages up to 5 kVac, weather protected
ER-15KV	For system voltages up to 15 kVac
ER-25KV	For system voltages up to 25 kVac
ER-35KV	For system voltages up to 35 kVac

Current Sensors:

ELCT5-31	Current sensor, 31-mm (1.22 in.) window
ELCT5-88	Current sensor, 88-mm (3.46 in.) window
ELCT30-3	Current sensor, 31-mm (1.22 in.) window
ELCT30-88	Current sensor, 88-mm (3.46 in.) window

CT200	Current sensor, 200-A-primary rating, 56-mm (2.2 in.) window
5SHT-101-E	Current sensor, 100-A-primary rating, 40-mm (1.6 in.) window
5SHT-151-E	Current sensor, 150-A-primary rating, 40-mm (1.6 in.) window
5SHT-500-E	Current sensor, 50-A-primary rating, 40-mm (1.6 in.) window
7SHT-301-E	Current sensor, 300-A-primary rating, 64-mm (2.5 in.) window
7SHT-401-E	Current sensor, 400-A-primary rating, 64-mm (2.5 in.) window

Accessories:

RK-332	Remote indication and reset, includes two 120-V pilot lights, a reset push button, and legend plates
SE-IP65CVR-G	Hinged transparent cover, IP65
SE-MRE-600	Moisture-resistant enclosure for ER-600VC
PGA-0520	Percent analog meter
SE-330-SMA	Surface mount adapter
AC300-MEM-00	Industrial-grade microSD card

Software:⁽⁴⁾

SE-MON330 Software	SE-330 Data-display Program for PC, version 4.0 or higher
NGR Monitor	
Set-Point Assistant	SE-330 settings guide

NOTES:

- ⁽¹⁾ Profibus models only available on legacy SE-330.
- ⁽²⁾ Includes Modbus TCP and EtherNet/IP protocols.
- ⁽³⁾ Includes IEC 61850 protocol only.
- ⁽⁴⁾ Available at www.littelfuse.com/relayscontrols.

8. WARRANTY

The SE-330 Neutral-Grounding-Resistor Monitor is warranted to be free from defects in material and workmanship for a period of five years from the date of purchase.

Littelfuse will (at the choice of Littelfuse) repair, replace, or refund the original purchase price of an SE-330 that is determined by Littelfuse to be defective if it is returned to Littelfuse, freight prepaid, within the warranty period. This warranty does not apply to repairs required as a result of misuse, negligence, an accident, improper installation, tampering, or insufficient care. Littelfuse does not warrant products repaired or modified by non-Littelfuse personnel.

9. TEST PROCEDURES

NOTE: Ensure the real-time clock is set. See Section 4.2.

9.1 Resistor-Fault Tests

Perform tests with system de-energized and supply voltage applied to the SE-330.

9.1.1 Calibration and Open Test

Test Equipment: 20-k Ω and 100-k Ω , 1/4-watt, 1% calibration resistors (calibration resistors are supplied with SE-330).

Procedure:

- Remove connections to terminals 6 and 7.
- Connect the 20-k Ω resistor to terminals 6 and 7.
- Set switch S5 to the 20-k Ω position.
- Perform calibration as per Section 2.2.
- The CALIBRATED LED should be on.
- Press RESET.
- Remove the 20-k Ω resistor and wait for the resistor-fault trip time.

PASS: The SE-330 should trip on resistor fault.

- Connect the 100-k Ω resistor to terminals 6 and 7.
- Set switch S5 to the 100-k Ω position.
- Perform calibration as per Section 2.2.
- The CALIBRATED LED should be on.
- Press RESET.
- Remove the 100-k Ω resistor and wait for the resistor-fault trip time.

PASS: The SE-330 should trip on resistor fault.

NOTE: Resistor-fault-trip reset can take up to one second.

9.1.2 Voltage Test

Test Equipment: 0 to 120 Vac voltage source, multimeter, and ER sensing resistor.

NOTE: Use an isolation transformer if the test-voltage source does not provide dc continuity for the SE-330 resistance-measuring circuit.

NOTE: Applying the test voltage to the R and G terminals will damage the SE-330 and the ER sensing resistor. The V_N TRIP LEVEL is the trip voltage at terminal N, not terminal R.

Procedure:

- Connect the ER sensing resistor to the SE-330 and calibrate the SE-330.
- Disconnect the wire from sensing-resistor terminal N. A resistor-fault trip will occur.
- Set the voltage source to 0 V.
- Connect the voltage source between sensing resistor N and G terminals.
- Set the V_N TRIP LEVEL (VAC) to 20.
- Press RESET.
- The RESISTOR FAULT TRIP LED should be off.
- Increase the test voltage to 25 Vac for 20-k Ω sensors or 120 Vac for 100-k Ω sensors and wait for the resistor-fault trip time.

PASS: The SE-330 should trip on RESISTOR FAULT. A time delayed ground-fault trip follows the resistor-fault trip if neutral voltage persists after the resistor fault. For legacy units with firmware revision 6 or less, this does not apply.

9.2 Sensing-Resistor Test

Test Equipment: Multimeter

Procedure:

- Disconnect the sensing resistor.
 - Measure the resistance between sensing-resistor terminals R and N.
- PASS:** Resistance should be between 19.6 and 20.4 k Ω for 20-k Ω sensing resistors. Resistance should be between 98 and 102 k Ω for 100-k Ω sensing resistors.
- Measure the resistance between sensing-resistor terminals R and G in both directions.

PASS: Resistance should be greater than 10 M Ω in both directions.

APPENDIX A

SE-330 REVISION HISTORY

MANUAL RELEASE DATE	MANUAL REVISION	PRODUCT REVISION (REVISION NUMBER ON PRODUCT LABEL)	FIRMWARE VERSION
June 30, 2018	11-A-063018	17A	3.00 2.60
October 18, 2017	10-P-101817	17	2.60
December 7, 2016	10-N-120716	16	2.55
September 21, 2016	10-M-092116		2.54 2.53
June 30, 2016	10-L-063016		2.52
September 8, 2015	10-K-090815	15	2.50
June 22, 2015	10-J-062215		2.40
May 20, 2015	10-I-052015		
March 3, 2015	10-H-030315		
July 7, 2014	10-G-070714	14	2.31 2.30
April 14, 2014	10-F-041414	13	2.20
January 8, 2014	10-E-010814	12	
		11	
November 29, 2013	10-D-112913	10A	2.10
October 8, 2013	10-C-100813		2.08
September 12, 2013	10-B-091213		2.07
August 30, 2013	10-A-083013		10

MANUAL REVISION HISTORY

REVISION 11-A-063018

GENERAL

Manual format and many sections have been updated.

SECTION 1

Descriptions for NGR short detection and assignable relays added.

SECTION 2

Enhanced health status added.

SECTION 6

NGR short detection specifications added.

REVISION 10-P-101817

SECTION 2

New features described in Section 2.8.

SECTION 3

Installation instruction updated.

SECTION 4

SD Card note added.

SECTION 5

Troubleshooting information added.

SECTION 7

Ordering information updated.

REVISION 10-N-120716

APPENDIX A

Revision history updated.

REVISION 10-M-092116

SECTION 4

Firmware upgrade instructions updated.

APPENDIX A

Revision history updated.

REVISION 10-L-063016

SECTION 4

Section 4.1.2 updated.

SECTION 6

microSD storage capacity increased to 32 GB.

RCM certification added.

REVISION 10-K-090815

SECTION 4

Section 4.1.2 updated.

SECTION 5

SD card diagnostic troubleshooting updated.

REVISION 10-J-062215

SECTION 2

Section 2.1.7 added.

SECTION 4

SD card approximate annual data logging usage updated.

SE-MON330 software version updated.

SECTION 6

Resistor-fault trip level ranges added.

REVISION 10-I-030315

SECTION 4

SD card storage capacity updated.

SECTION 6

SD card storage capacity specification updated.

REVISION 10-H-030315

SECTION 2

Sections 2.1.6 and 2.1.7 added.

SECTION 4

Section 4.2 new features added.

SECTION 6

Resistor-fault circuit trip time update

REVISION 10-G-070714

SECTION 6

Added CE, C-Tick, and FCC information.

REVISION 10-F-041414

APPENDIX A

Hardware revision updated.

REVISION 10-E-010814

SECTION 6

Extended operating temperatures added to all sensing resistors and SE-CS30 current sensors.

REVISION 10-D-112913

SECTION 6

CE added to sensing resistors.

SECTION 7

Ordering information updated.

REVISION 10-C-100813

SECTION 2

Section 2.8 updated.

SECTION 4

Real-time clock note added in Section 4.2.

SECTION 5

LED and relay status added to troubleshooting solutions.

SECTION 7

Ordering information updated.

REVISION 10-B-091213

APPENDIX A

Hardware revision updated.

REVISION 10-A-083013

SECTION 1

Faceplate updated.

New features added.

SECTION 2

Communications options updated.

Configuration switches updated.

Indication relays explanation added.

Non-volatile-memory error added.

SECTION 3

Connection drawing updated.

SECTION 4

Section heading changed to Data Interfaces.

Updated with microSD and USB interfaces.

Upgrade procedure added.

SECTION 5

Non-volatile-memory error added.

Switch S8 diagnostic LED error removed.

SECTION 6

Ground-fault circuit trip level updated.

USB communications specifications added.

Resistor-fault accuracy changed.

microSD memory card specifications added.

SECTION 7

Ordering information updated.

SE-330-SMA surface mount adapter listed as an accessory only.

APPENDIX A

Added revision history.

HARDWARE REVISION HISTORY

HARDWARE REVISION 17A

Additional EMC filter capacitors added.

HARDWARE REVISION 17

Enhanced transient protection added.

HARDWARE REVISION 16

microSD storage capacity increased to 32 GB.

HARDWARE REVISION 15

RTC circuit updated.

HARDWARE REVISION 14

CE and C-Tick compliance added.

HARDWARE REVISION 13

ESD sensitivity of front-panel dials reduced

HARDWARE REVISION 12

Fiber ethernet support improved.

HARDWARE REVISION 11

ESD sensitivity of USB and SD card connectors reduced.

HARDWARE REVISION 10A

RTC circuit updated.

HARDWARE REVISION 10

SE-330 platform updated to include USB and microSD interfaces, programmable trip level (MEM) feature, and ability to add future options.

Real-time clock and rechargeable battery added.

Dual cable and fiber Ethernet ports added.

FIRMWARE REVISION HISTORY

FIRMWARE REVISION 3.00

NGR short detection functionality added.

Assignable functions for K1, K2, and K3 added.

Standard and non-accumulating selections added to ground-fault trip time algorithm.

UTC Offset added to SNTP Client functionality.

SD card logging limited to two most recent months of data.

FIRMWARE REVISION 2.60

Option to display only critical diagnostic codes with DIAGNOSTIC LED added.

FIRMWARE REVISION 2.55

IEC 61850 network watchdog resets corrected.

FIRMWARE REVISION 2.54

NAND FLASH bit-error-correction update to prevent solid-red diagnostic LED error when bit errors are correctable.

Resistor-fault trip level added to web interface.

MODBUS TCP/IP write response byte count corrected.

TCP Keep Alive network setting no longer resets to 5 s after power cycle.

FIRMWARE REVISION 2.53

NAND FLASH bit error correction code to prevent solid-red diagnostic error fixed.

FIRMWARE REVISION 2.52

Improved compatibility with Internet Explorer* web browser.

FIRMWARE REVISION 2.50

Support for adjustable resistor-fault trip level added.

Web page functionality re-enabled for Ethernet options.

FIRMWARE REVISION 2.40

Support for geo-magnetic filter added.

Support for 12 to 60 s resistor-fault trip time added.

Improved log file descriptions.

IEC 61850 GOOSE network input support now always enabled.

Improved compatibility for Modbus TCP.

Web page disabled for Ethernet options. This will be enabled in a future firmware release.

IP setting changes for Ethernet options now require power cycle to take effect.

FIRMWARE REVISION 2.31

SD card and USB diagnostic events no longer cause a trip.

FIRMWARE REVISION 2.30

Remote calibration feature added.

FIRMWARE REVISION 2.20

Added support for Ethernet/IP protocol.

IED name now reported correctly through IEC 61850 interface.

Ethernet/IP and Modbus communications card LED status updated.

Hardware version viewable in the SE-MON330 software and through the MODBUS and IEC 61850 servers.

FIRMWARE REVISION 2.10

Added support for IEC 61850 and DeviceNet protocols.

FIRMWARE REVISION 2.08

Added support for communications options.

FIRMWARE REVISION 2.07

Updated firmware to include USB and microSD interfaces, datalogging, and firmware update via microSD.

K2 and K3 indication relays can be configured for fail-safe or non-fail-safe operation.

Trip records increased to 100 with date and time stamping.

* Bluetooth, Internet Explorer, National Electric Code, and microSD are trademarks of their respective owners.