

© - TE Connectivity. All Rights Reserved.

REVISIONS				
P	LTR	DESCRIPTION	DATE	APVD
	B3	REV PER ECR-22-161953	29DEC2022	LP DSC

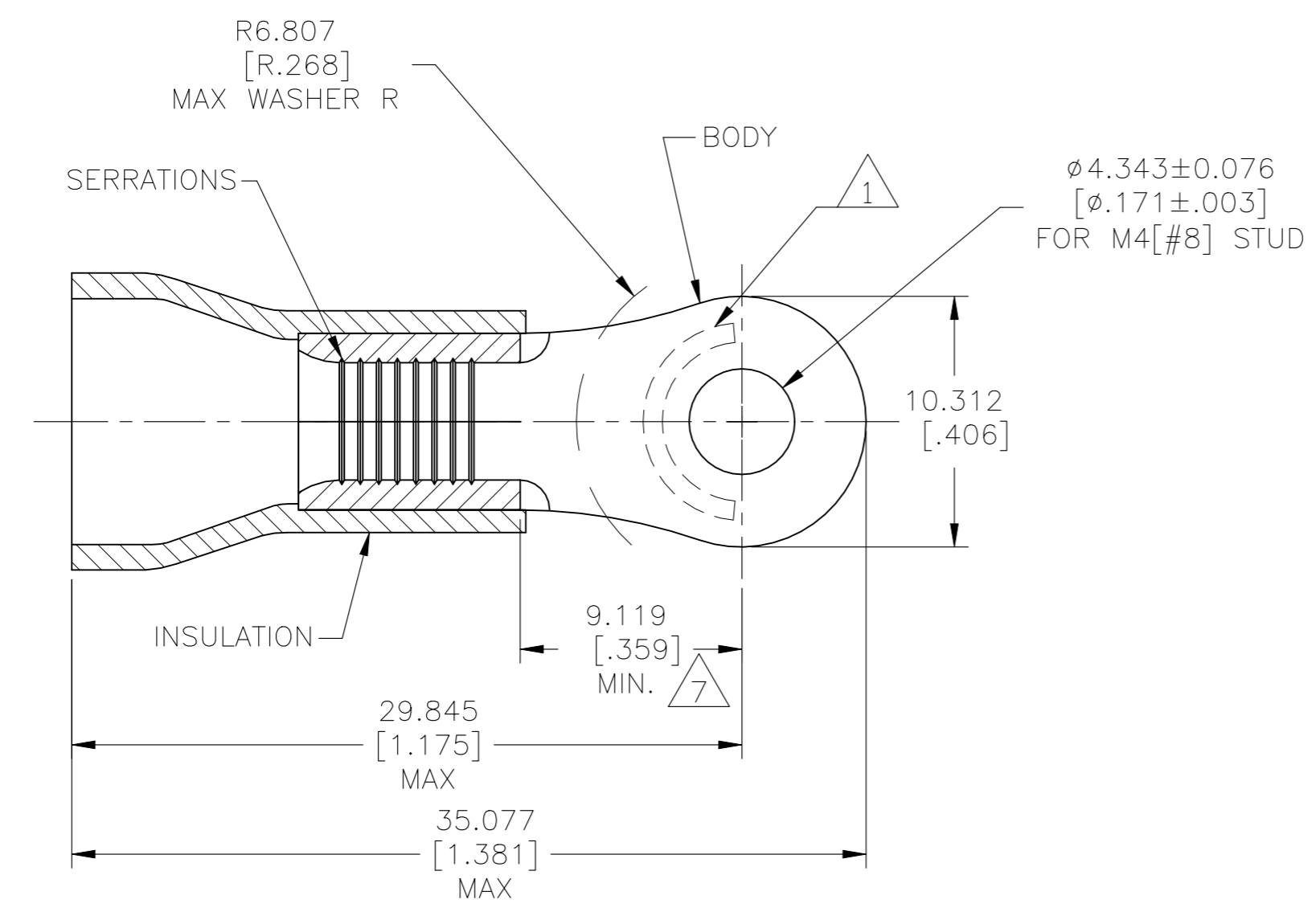

<b>AMP</b> WIRE RANGE
8 AWG STRANDED

- 1 STAMP AMP 8\* LOCATE APPROX AS SHOWN
- 2 BODY MATERIAL THK: 1.219±0.076[.048±.003]
- 3 TAPE ITEMS ARE ON 30.480 [1.200] CENTERS
- 4 FINISH:  
BODY - TIN PLATE 0.00254[.000100] MIN EXT THK PER ASTM B545  
INSULATION COLOR - RED
- 5 MATERIAL:  
BODY - COPPER PER ASTM B152  
INSULATION - PVC
- 6 WIRE INSULATION DIAMETER: Ø9.144[Ø.360] MAX
- 7 APPLIES FROM EDGE OF METAL WIRE BARREL TO CENTER OF STUD HOLE

500	ON TAPE	696049-2
100	LOOSE PIECE	696049-1
QTY	PACKAGE TYPE	PART NO.

<b>AMP INCORPORATED CUSTOMER SERVICE SYSTEMS</b>		MAX RECOMMENDED OPERATING TEMPERATURE: 105°C [221°F]	THIS DRAWING IS A CONTROLLED DOCUMENT.		DWN JR RUTH 31MAY00	<b>STE</b> TE Connectivity				
FOR ADDITIONAL PRODUCT INFORMATION OR COPIES OF DRAWINGS AND TECHNICAL DOCUMENTS	PRODUCT INFORMATION CENTER 1-800-522-6752	VOLTAGE RATING: 600V MAX	DIMENSIONS: mm [INCHES]	TOLERANCES UNLESS OTHERWISE SPECIFIED:	CHK M FEHER 31MAY00	NAME TERMINAL, RING TONGUE, PLASTI-GRIP, WIRE SIZE: 8 AWG				
FOR APPLICATION TOOLING INFORMATION	TOOLING ASSISTANCE CENTER 1-800-722-1111	CIRCULAR MIL AREA: 6.64-10.54mm <sup>2</sup> [13,100-20,800] STRANDED		0 PLC ± - 1 PLC ± - 2 PLC ± - 3 PLC ± 0.127[.005] 4 PLC ± - ± - ANGLES	APVD T MICHIELUTTI 31MAY00	APPLICATION SPEC 114-2161				
FOR ORDER ENTRY	1-800-526-5142	THIS DRAWING IS A CONTROLLED DOCUMENT FOR AMP INCORPORATED. IT IS SUBJECT TO CHANGE AND THE CONTROLLING ENGINEERING ORGANIZATION SHOULD BE CONTACTED FOR THE LATEST REVISION.	MATERIAL 5	FINISH 4	PRODUCT SPEC -	WEIGHT -	SIZE A3	CAGE CODE 00779	DRAWING NO C-696049	RESTRICTED TO -
					CUSTOMER DRAWING		SCALE 4:1	SHEET 1 OF 1	REV B3	