

DRAWING NUMBER

R 6161-02
- R6169-02



THIRD ANGLE PROJECTION

DO NOT SCALE

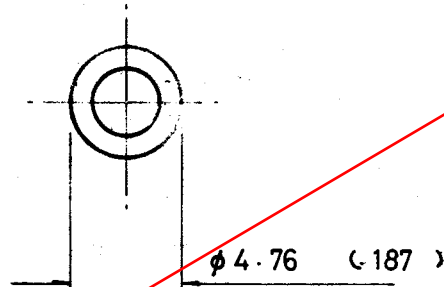
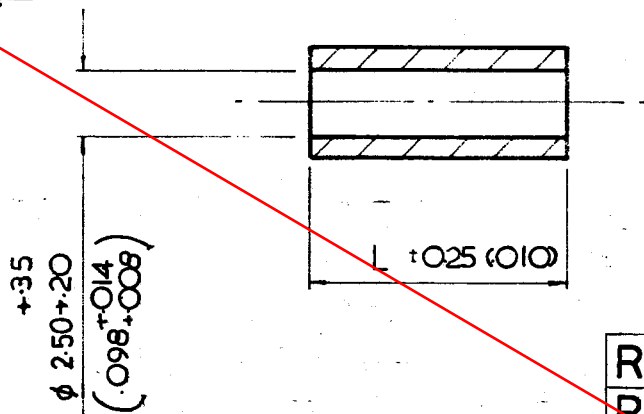

OBSOLETE

NOTE
1 HOLE TO BE MADE IN ACCORDANCE WITH BS 4320 : 1968

R 6169 - 02		20	.787
R 6168 - 02		18	.708
R 6167 - 02		16	.630
R 6166 - 02		14	.551
R 6165 - 02		12	.472
R 6164 - 02		10	.394
R 6163 - 02		8	.315
R 6162 - 02		6	.236
R 6161 - 02		4	.157
PART NO	DRG NO	MM	INS
		L ± 0.25 (-0.10)	

11	5-3-79	FINISH WAS
10	31-10-78	WAS MADE TO
2	24-1-75	339
1	2-6-75	
ISS.	DATE	CHANGE
APPD.	<i>[Signature]</i>	
CHKD.	<i>R. Driscoll</i>	
DRAWN	<i>[Signature]</i>	
OLD REF.	R 6061/1- 69/1	
ASSY. DRAWING		

CAM NO	1095
MACH NO	ESCO

HARWIN ENGINEERS S.A.
PORTSMOUTH PO6 IRT

MATERIAL BRASS **BS2874 CZ121**
TITLE
CLEARANCE SPACER - ROUND

FINISH NICKEL PLATE **F0201**
TOLERANCES
FRAC. ± 1/64 DEC ± .005 MM ± .13
DIMS. INMM (INS) SCALE —

DRAWING NUMBER
R 6169 - 02
- R6161 - 02