

PART NUMBER	REV	FIRST USED	POWER UNIT	FEED TYPE	DESCRIPTION
1855267-1	A	122500-1	LEADMAKER	AIR FEED	CUTS CARRIER
1855267-2	A	565435-5	BENCH MODEL K	AIR FEED	CUTS CARRIER
1855267-3	A	354500-1	BENCH MODEL G	AIR FEED	CUTS CARRIER
7-1855267-7	A	-	-	-	SPARE PARTS

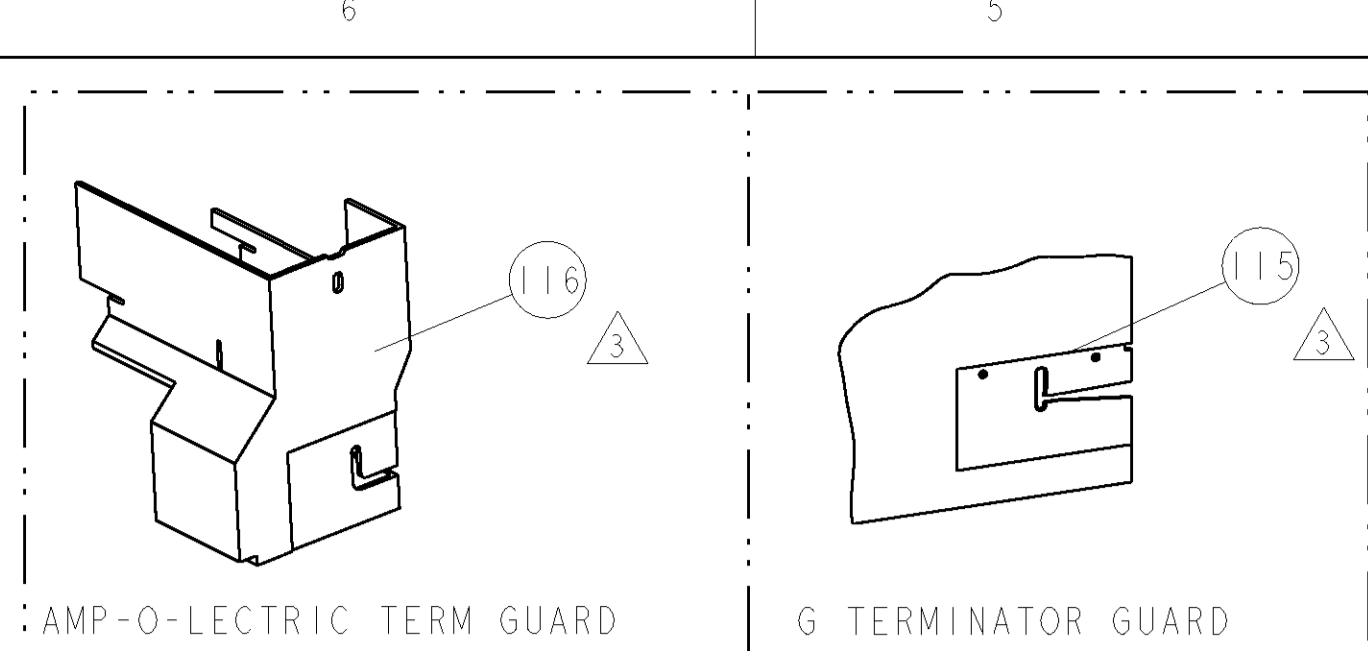

TERMINAL NAME: TERMINAL, RING		DELPHI TERM - DELPHI CRIMP SPECS			
TYCO PN	MFR PN	CRIMP HEIGHT	WIRE SIZE	REF SETTING	
1949352	13517639	-	-	-	
-	-	2.64±0.05mm [1.04±.002]	2.0mm2	B2	
-	-	2.54±0.05mm [1.00±.002]	1.5mm2	B7	
-	-	2.43±0.05mm [1.096±.002]	1.0mm2	C5	
-	-	-	-	-	
CRIMP	SIZE	TYPE	RANGE		
-	-	-	-		
-	-	WIRE	3.30mm [1.30]	F	1.0-2.0mm2
-	-	INSUL	4.31mm [1.70]	F	∅2.45-3.05mm MAX
WIRE STRIP LENGTH	TERM APPL SPEC	FEED	APPLICATOR INSTRUCTIONS	SET UP GAGE	
4.90-5.28mm	NONE	13.90	408-8040	458637-1	

LOC	DIST	REV	DESCRIPTION	DATE	BY	APPD
A	66		PRODUCT RELEASE	10MAY2007	CMR	TE

- ⚠ RECOMMENDED SPARE PARTS
- ⚠ GREASE LIGHTLY
- ⚠ GUARD MUST BE IN PLACE WHEN OPERATING APPLICATOR IN A BENCH MACHINE
- ⚠ INSTALL ITEMS 101, 102, AND 119 ON SIDE OF STRIPPER ON APPL HOUSING USING ITEM 21.

*** WARNING**
ON INSTALLATION, SET WIRE DISC TO LARGEST WIRE SIZE SETTING. USE OF SETTINGS BELOW MIN. REQUIRED CRIMP HEIGHT SETTING WILL CAUSE DAMAGE TO CRIMP TOOLING.

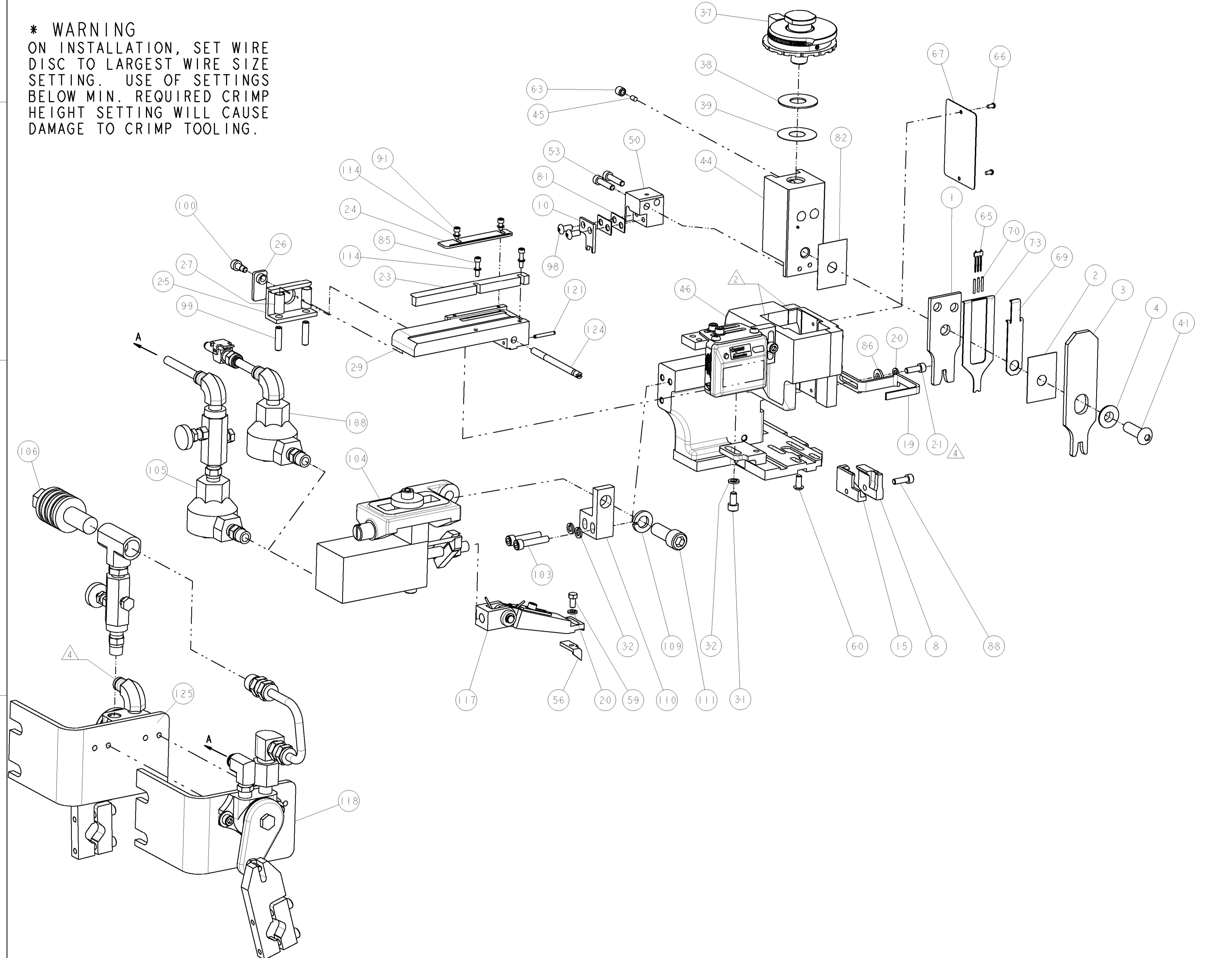

-	-	1	-	-	455350-4	AIR BLAST ASS'Y	125	
-	-	1	1	1	690432-3	ADJUSTMENT SCREW	124	
-	-	1	1	1	4-21028-0	PIN, SLOTTED SPRING .094 X .750	121	
⚠	-	18	24	18	IN	27319-4	TUBING, POLY-FLO, NATURAL	119
-	-	1	1	-	692655-6	AIR FEED VALVE ASSEMBLY	118	
-	-	1	1	1	461062-1	FEED FINGER ASSEMBLY	117	
-	-	REF	-	-	455749-1	GUARD WINDOW	116	
⚠	-	REF	-	-	679532-1	INSERT, GUARD	115	
-	-	4	4	4	21024-2	WASHER, SPRG LOCK, REG NO 4	114	
-	-	1	1	1	3-21001-5	SCR, SKT HD CAP 3/8-16 X 1.000	111	
-	-	1	1	1	459610-1	MOUNT, FEED BRACKET	110	
-	-	1	1	1	21024-8	WASHER, SPRG LOCK, REG 3/8	109	
-	-	1	1	1	692655-7	AIR FEED VALVE ASSEMBLY	108	
-	-	-	-	-	24042-2	VALVE, SLEEVE, 3-WAY	106	
-	-	-	-	-	692655-5	AIR FEED VALVE ASSEMBLY	105	
-	-	1	1	1	461065-1	ASSEMBLY, AIR FEED	104	
-	-	2	2	2	3-21000-9	SCR, SKT HD CAP 10-32 X 1.000	103	
-	-	1	1	1	986220-3	CLAMP, CABLE, BLACK	102	
-	-	1	-	1	23238-1	INSERT, COUPLING	101	
-	-	1	1	1	22353-8	SCR, SHLD, SLOT HD, 3/16 DIA	100	
-	-	2	2	2	5-21006-6	SCR, SET, CUP POINT 10-32 X .750	99	
-	-	2	2	2	2-21002-1	SCR, BTN SKT HD CAP 8-32 X .375	98	
⚠	-	2	2	2	1-21000-3	SCR, SKT HD CAP 4-40 X .250	91	
⚠	-	1	1	1	2-21000-7	SCR, SKT HD CAP 8-32 X .500	88	
-	-	1	1	1	21055-7	WASHER, FLAT, REG NO 10	86	
-	-	2	2	2	1-21000-5	SCR, SKT HD CAP 4-40 X .500	85	
-	-	1	1	1	455888-1	SPACER, CRIMPER	82	
-	-	2	2	2	1-240641-7	SPACER	81	
-	-	1	1	1	1490525-2	DEPRESSOR, WIRE	73	
-	-	1	1	1	4088040	SF APPL INST 408-8040	72	
-	-	1	1	1	217238-1	GENERAL INSTRUCTION PKG	71	
-	-	3	3	3	2-23147-2	SPRING, COMPRESSION	70	
-	-	1	1	1	1490524-2	DEPRESSOR, SPACER	69	
-	-	1	1	1	461264-5	PLATE, IDENTIFICATION	67	
-	-	2	2	2	21017-2	SCREW, DRIVE	66	
-	-	1	1	1	1424350-1	HOLDER, PIN, WIRED	65	
-	-	1	1	1	21009-2	SCR, SET, SELF LOCKING 1/4-20 X .250	63	
-	-	1	1	1	22733-8	SCR, BHSC, SELF-LOCKING, 8-32 X .375	60	
-	-	1	1	1	2-22603-0	SCR, HEX HD CAP 8-32 X .312	59	
-	-	1	1	1	3-694433-9	FEED PAWL	56	
-	-	2	2	2	2-21000-9	SCR, SKT HD CAP 8-32 X .750	53	
-	-	1	1	1	1583893-6	HOLDER, SLUG BLADE	50	
-	-	1	1	1	1633399-1	APPL., BASIC AIR FEED SUB ASSY	46	
-	-	1	1	1	690191-1	PLUG, NYLON	45	
-	-	1	1	1	1-455673-4	RAM, SIDE FEED	44	
-	-	1	1	1	7-21002-9	SCR, BTN SKT HD CAP 5/16-24 X 1.00	41	
-	-	1	1	1	690125-1	SHIM SUB-ASSY	39	
-	-	1	1	1	469367-7	SHIM	38	
-	-	1	1	1	879103-2	FINE ADJUST HEAD ASSEMBLY	37	
-	-	3	3	3	21024-5	WASHER, SPRG LOCK, REG NO 10	32	
-	-	1	1	1	3-21000-4	SCR, SKT HD CAP 10-32 X .375	31	
-	-	1	1	1	2-844048-6	PLATE, REAR STRIP GUIDE	29	
-	-	2	2	2	22281-9	SPRING, COMPRESSION	27	
-	-	1	1	1	356835-1	LEVER, DRAG RELEASE	26	
-	-	1	1	1	240792-1	DRAG, TERMINAL	25	
-	-	1	1	1	1-690438-5	FRONT STRIP GUIDE	24	
-	-	1	1	1	2-189124-1	GUIDE, FRONT STRIP	23	
-	-	1	1	1	2-21000-7	SCR, SKT HD CAP 8-32 X .500	21	
-	-	2	2	2	21024-4	WASHER, SPRG LOCK, REG NO 8	20	
-	-	1	1	1	1-456468-1	STRIPPER, SPECIAL	19	
⚠	-	1	1	1	1-1633124-1	PLATE, REAR SHEAR	15	
⚠	-	1	1	1	1583859-5	BLADE, SLUG	10	
⚠	-	1	1	1	1633507-8	ANVIL, SPECIAL, COMBINATION	8	
-	-	1	1	1	2-238009-9	BLOCK, FL CRIMPER SPACER	4	
⚠	-	1	1	1	4-1633471-6	CRIMPER, INSULATION F	3	
⚠	-	1	1	1	455888-3	SPACER, CRIMPER	2	
⚠	-	1	1	1	3-456410-5	CRIMPER, WIRE PREMIUM	1	

DIMENSIONS: INCHES		TOLERANCES UNLESS OTHERWISE SPECIFIED:		DWG: C. REICHEL/DEFFER CHK: T. ELBIN APPD: T. BENCHOFF		Tyco Electronics Harrisburg, PA 17105-3608	
0 PLC	±	1 PLC	±0.1	2 PLC	±0.01	3 PLC	±0.001
4 PLC	±0.0001	ANGLES	±0.0001	NAME: FINE ADJUST SIDE FEED HDM APPLICATOR		SIZE: CAGE CODE: DRAWING NO: 00779 ©=1855267	
MATERIAL:		FINISH:		WEIGHT:		CUSTOMER DRAWING	
SCALE: 3:5		SHEET 1 OF 1		REV: A		RESTRICTED TO:	

CUSTOMER VIEWABLE ASSEMBLY