

# DS2149DK/DS21349DK T1/J1 Line Interface Unit Design Kit

[www.maxim-ic.com](http://www.maxim-ic.com)

## GENERAL DESCRIPTION

The DS2149DK/DS21349DK is a fully integrated design kit for the DS2149 and the DS21349 T1/J1 line interface units (LIUs). It contains the necessary circuitry to evaluate the device in all operation modes, including running the device in hardware and software mode.

## DESIGN KIT CONTENTS

- DS2149DK/DS21349DK Board
- DS2149 28-Pin PLCC
- DS21349 28-Pin PLCC

## FEATURES

- PLCC 28-Pin Socket for Multiple Part Evaluation
- Bantam and RJ48 Connectors, Transformers, and Termination Passives for LIU
- Two Separate and Controllable Transmit Paths for TTIP and TRING for Evaluating Multiple Transformers
- Equipment-Side Connector for External Data Source/Sink or External Remote Loopback
- On-Board T1 Crystal Oscillator
- On-Board 8051 Microprocessor for Software Mode Access
- Connector Accesses to CS, SCLK, SDI, and SDO for Firmware Development
- Controllable 5V and 3.3V for VCC and IO Pins to Support the DS2149 and DS21349 LIUs

## ORDERING INFORMATION

PART	DESCRIPTION
DS2149DK/ DS21349DK	T1/J1 Line Interface Unit Design Kit

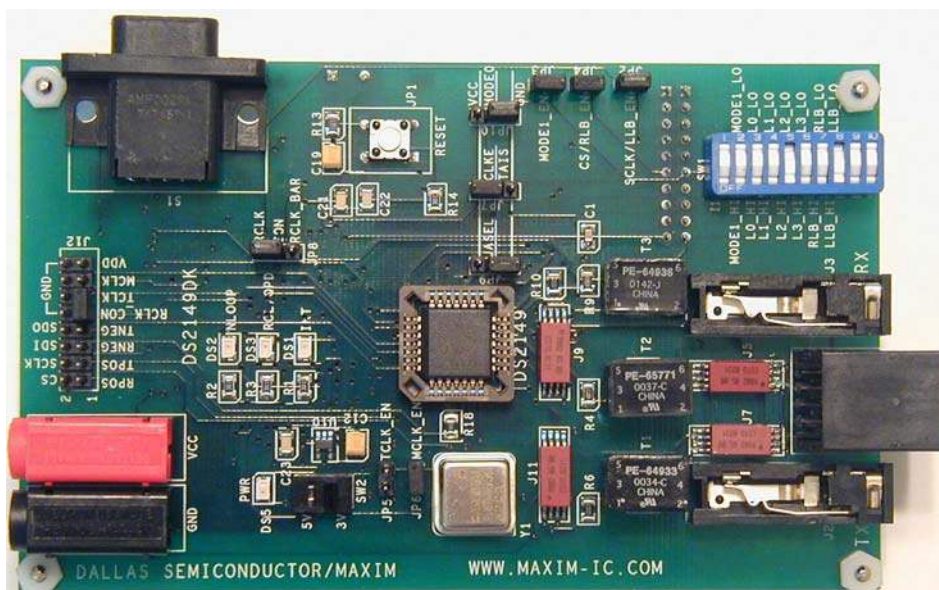

**COMPONENT LIST**

DESIGNATION	QTY	DESCRIPTION	SUPPLIER	PART
C1	1	0.001 $\mu$ F capacitor (SMT80123)	Digi-Key	—
C3, C6, C9, C12, C15–C17, C19	8	10 $\mu$ F capacitors (SMT80123)	Digi-Key	—
C4, C7, C10, C21	4	0.1 $\mu$ F capacitors (SMT80123)	Digi-Key	—
C5, C8, C11, C22, C23	5	0.01 $\mu$ F capacitors (SMT80123)	Digi-Key	—
C13, C14	2	10 $\mu$ F capacitors (SMT127240)	Digi-Key	—
C18, C20	2	22pF capacitors (SMT80123)	Digi-Key	—
DS1–DS3, DS5	4	Red LED	Digi-Key	LN1251C
DS7	1	150-mil SO, DS87C520-ECL	Dallas Semiconductor	DS87C520-ECL
J1	1	Connector, RJ48, 8-pin	Digi-Key	15-43-8588
J2, J3	2	Bantam connectors	Digi-Key	RTT34B02
J4–J11	8	COTO9802	Coto Technology	COTO9802
J12	1	100-mil, 16-pin vertical connector	Digi-Key	—
JP1	1	Pushbutton switch	Digi-Key	EVQPAE04M
JP2–JP6	5	100-mil SIP jumper 2 position	Digi-Key	—
JP7–JP10	4	100-mil SIP jumper 3 position	Digi-Key	—
PWR_CONNBAN2	1	Banana connector, 2-pin, red	Mouser Electronics	164-6219
PWR_CONNBAN1	1	Banana connector, 2-pin, black	Mouser Electronics	164-6218
R1–R3, R12, R14	5	300 $\Omega$ resistors (SMT80123)	Digi-Key	—
R4, R5	2	4.7 $\Omega$ resistors (SMT80123)	Digi-Key	—
R6, R7, R10, R11	4	0 $\Omega$ resistors (SMT80123)	Digi-Key	—
R8, R9	2	50.0 $\Omega$ resistors (SMT80123)	Digi-Key	—
R13, R15, R16	3	10.0k $\Omega$ resistors SMT80123)	Digi-Key	—
R17–R21	5	30 $\Omega$ resistors (SMT80123)	Digi-Key	—
RN1, RN2	2	1k $\Omega$ 10-pin resistor network	Digi-Key	—
S1	1	9-pin DB9P connector	Digi-Key	747459-1
SW1	1	10-position switch	Digi-Key	435668-9
SW2	1	6-pin DPDT switch	Digi-Key	SSA22
T1	1	1:3 T1 transformer	Pulse Engineering	PE-64933
T2	1	1:2 T1 transformer	Pulse Engineering	PE-65771
T3	1	1:1 T1 transformer	Pulse Engineering	PE-64936
U1	1	PLCCSMT28T0T socket	Pioneer Electronics	PLCCSMT28T0T
U2, U5, U7	3	150-mil SO, 74HC04, hex inverter	Digi-Key	TC74HC04AFN
U3, U4, U6	3	150-mil SO, 74HC03, open collector NAND gate	Digi-Key	SN74LS38D
U8	1	Darlington array	Texas Instruments	ULQ2003ADR
U9	1	150-mil SO, DS232AR	Dallas Semiconductor	DS232AR
U10	1	3.3V regulator	Maxim	MAX8887EZK33
X1	1	EC1-S-11.0592M XTAL low pro	Digi-Key	EC1-S-11.0592M
Y1	1	1.544MHz crystal oscillator	Digi-Key	NTH039A3-1.5440

## BOARD FLOORPLAN

Figure 1 shows the board layout for the DS2149DK. The DS2149 PLCC socket is in the center of the board. The line-side bantam connectors for the Tx and Rx differential pairs and transformers are at the bottom of the board, while the system connector and configuration jumpers are at the top. The LEDs for INT, INLOOP, and RCL/QPD are in the center of the board, right above the DS2149 socket. The power-supply connectors and power indicator LED are in the upper left corner of the board, while the DB9 serial connector is the upper right. A T1 oscillator sits to the left of the DS2149 socket below a switch for changing the voltage to the DS2149 socket from 5V to 3.3V. Please refer to the general locations on the board when this document references specific items on the DS2149DK.

Figure 1. Board Floorplan

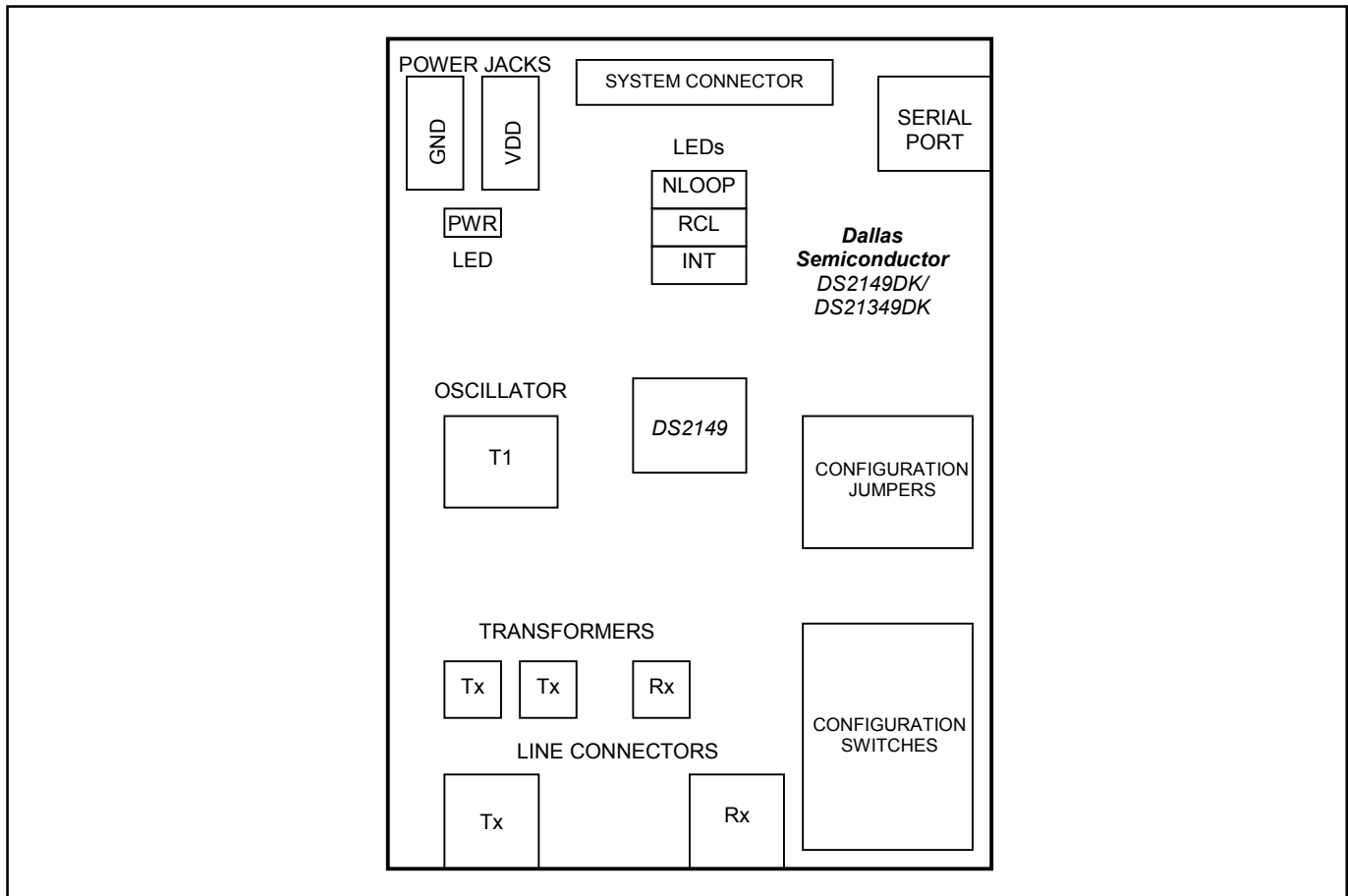

## LINE-SIDE CONNECTIONS

The DS2149DK/DS21349DK implements the Tx and Rx line interface networks recommended in the DS2149 and DS21349 data sheets and as shown in [Figure 2](#). To connect the DS2149DK/DS21349DK to T1 or J1 test equipment, connect the equipment to the RJ48 connector or to the two bantam connectors, J2 and J3. Please notice the relays disconnecting TTIP and TRING on T1 and T2. These relays disconnect the series resistors R4 and R5, which is recommended for some long-haul configurations. Pin 16 on the system connector serves as the control line for the relays. When pin 16 is high, T2 is enabled with TTIP and TRING. When it is held low, T1 is enabled with TTIP and TRING.

**Figure 2. Line-Side Circuitry**

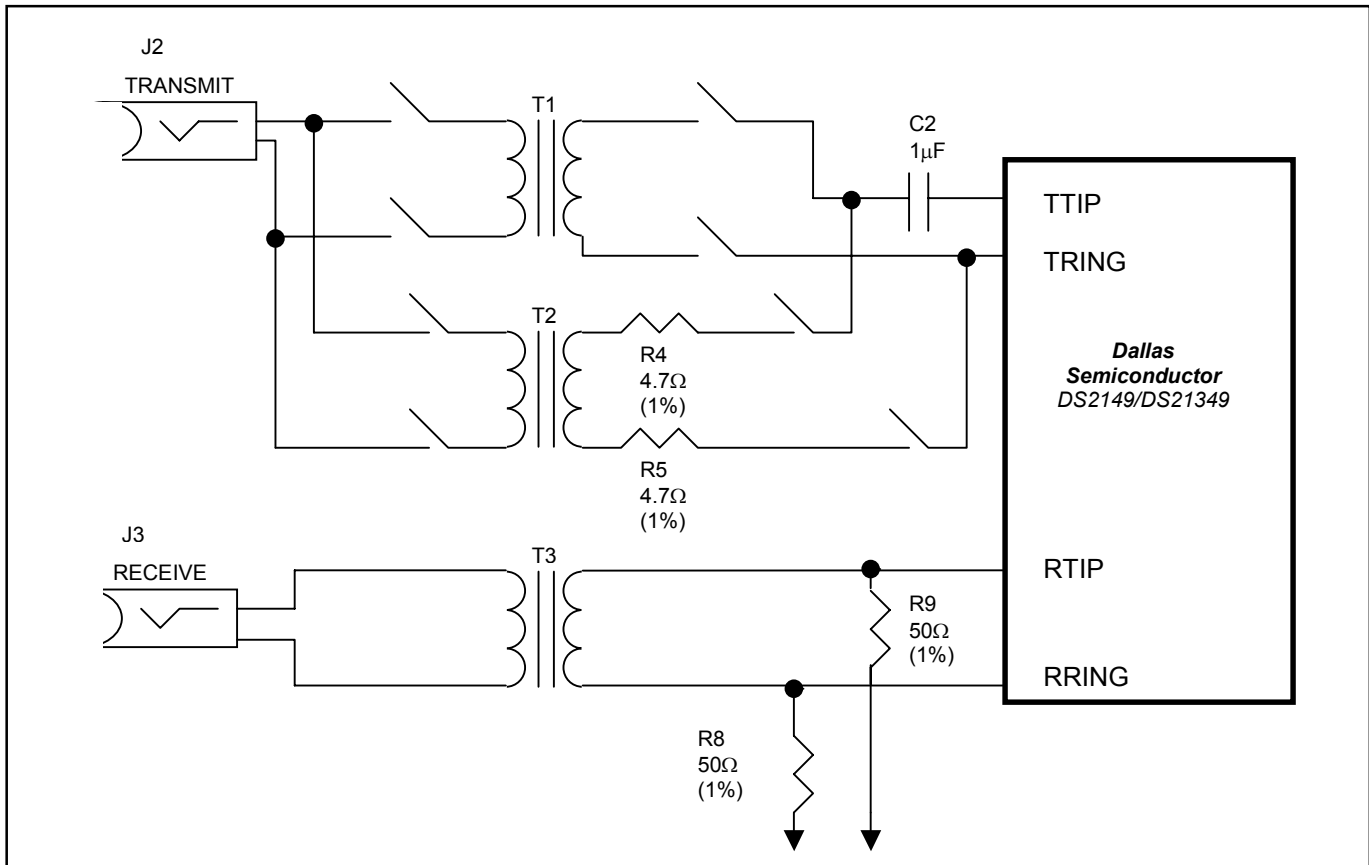

## SYSTEM CONNECTOR

A 16-pin system connector at the top of the board gives access to the following signals: RPOS, TPOS, RNEG, TNEG, RCLK\_CON, TCLK, MCLK, VDD, GND, CS, SCLK, SDI, and RELAY\_CONTROL. By using jumpers to connect TCLK to RCLK\_CON, TPOS to RPOS, and TNEG to RNEG, the system connector can also be used to implement an external remote loopback. Additionally, the system connector can read and write to the device without going through the on-board microcontroller. With this feature, you can quickly use this design kit as a working prototype and begin writing firmware for your system. [Figure 3](#) shows a representation of the system connector.

**Figure 3. System Connector**

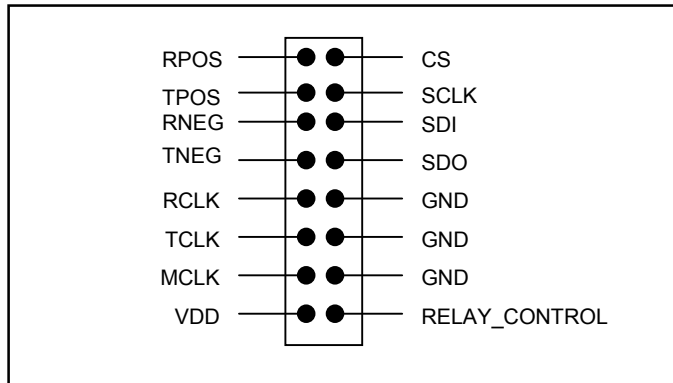

## POWER-SUPPLY CONNECTORS

Connect a 5.0V power supply across the red (VDD) and black (GND) banana jacks. The red PWR LED indicates power is applied to the board. Select the appropriate voltage that needs to be applied to VDD from the power switch below the PWR LED, depending if you are using a DS2149 (5V) or DS21349 (3.3V).

## MICROCONTROLLER AND SERIAL CONNECTOR

The DS2149DK/DS21349DK contains an on-board 8051 microcontroller with factory-installed firmware loaded into the microcontroller's EPROM. This firmware translates memory access requests from the RS-232 serial port into register access to the DS2149 or DS21349 in software mode. DemoView, a software application created by Dallas Semiconductor, allows easy read-write access for this device.

## INSTALLING AND RUNNING THE SOFTWARE

DemoView is a general-purpose program that supports several Dallas Semiconductor design kits. To install the DemoView software, run SETUP.EXE from the DemoView.ZIP file. (Download DemoView.ZIP from our website, [www.maxim-ic.com/telecom](http://www.maxim-ic.com/telecom).) After installation, run the DEMOVIEW.EXE program with the DS2149DK/DS21349DK board powered up and connected to the PC. In the opening screen, click the REGVIEW button. Select the correct serial port in the Port Selection dialog box, then click OK. To configure DEMOVIEW to support the DS2149DK/DS21349DK, open the File pulldown menu and select Definition File. In the Choose Definition File dialog box, select DS2149DK.DEF and click Open.

After selecting the definition file, the main part of the REGVIEW window displays the DS2149's memory map. To select a register, click on it in the register map. When a register is selected, the full name of the register and its bit map are displayed at the bottom of the REGVIEW window. Bits that are logic 0 are displayed in white, while bits that are logic 1 are displayed in green.

The DemoView software supports the following actions:

- Toggle a bit. Select the register in the register map and then click the bit in the bit map.
- Write a register. Select the register, click the Write button, and enter the value to be written.
- Write all registers. Click the Write All button and enter the value to be written.
- Read a register. Select the register in the register map and click the Read button.
- Read all registers. Click the Read All button.

## BASIC CONFIGURATION

The following example configurations provide a quick start to using the DS2149DK/DS21349DK, although there are many ways they can be configured. To set up other configurations, refer to the DS2149/DS21349 data sheets in addition to this data sheet.

### T1 Hardware Mode—External Remote Loopback

- 1) On the system connector, jumper TPOS to RPOS, TNEG to RNEG, RCLK\_CON to TCLK, and RELAY\_CONTROL to GND.
- 2) JP8, jumper RCLK to CON.
- 3) Remove JP5, TCLK\_EN.
- 4) Jumper JP6 MCLK\_EN.
- 5) JP9, JASEL, jumper to GND.
- 6) JP7, TAIS, jumper to GND.
- 7) JP10, MODE0, jumper to GND.
- 8) Jumper JP3, MODE1\_EN.
- 9) Jumper JP4, RLS\_EN.
- 10) Jumper JP2, LLB\_EN.
- 11) On SW1, switch MODE1 to MODE1\_LO.
- 12) On SW1, switch L0 to L0\_HI.
- 13) On SW1, switch L1 to L1\_HI.
- 14) On SW1, switch L2 to L2\_LO.
- 15) On SW1, switch L3 to L3\_LO.
- 16) On SW1, switch RLB to RLB\_LO.
- 17) On SW1, switch LLB to LLB\_LO.
- 18) Place appropriate device in socket.
- 19) Select the power 5V or 3V depending on which device you use.
- 20) Connect J2 and J3 to test equipment

Device should be in external remote loopback.

### T1 Software Mode—External Remote Loopback

- 1) On the system connector, jumper TPOS to RPOS, TNEG to RNEG, RCLK\_CON to TCLK, and RELAY\_CONTROL to GND.
- 2) JP8, jumper RCLK to CON.
- 3) Remove JP5, TCLK\_EN.
- 4) Jumper JP6 MCLK\_EN.
- 5) JP9, JASEL, jumper to GND.
- 6) JP7, TAIS, jumper to GND.
- 7) JP10, MODE0, jumper to GND.
- 8) Jumper JP3, MODE1\_EN.
- 9) Jumper JP4, RLS\_EN.
- 10) Jumper JP2, LLB\_EN.
- 11) On SW1, switch MODE1 to MODE1\_HI.
- 12) Place appropriate device in socket.
- 13) Select the power 5V or 3V depending on which device you use.
- 14) Connect J2 and J3 to test equipment.
- 15) Load the DemoView software.
- 16) Select RegView.
- 17) Load the DS2149.DEF file.
- 18) Write CR1 to 0x03.
- 19) Write CR2 to 0x00.
- 20) Write CR3 to 0x00.
- 21) Write CR4 to 0x00.

Device should be in external remote loopback.

## **DS2149/DS21349 INFORMATION**

For more information about the DS2149 and DS21349, please consult the DS2149 and DS21349 data sheets available on our website, [www.maxim-ic.com/telecom](http://www.maxim-ic.com/telecom).

## **TECHNICAL SUPPORT**

For technical support, please email your questions to [telecom.support@dalsemi.com](mailto:telecom.support@dalsemi.com).

## **SCHEMATICS**

The DS2149DK/DS21349DK schematics are featured in the following 14 pages.

# DS2149 / DS21349 DESIGN KIT

## T1 / J1 LINE INTERFACE UNIT DESIGN KIT

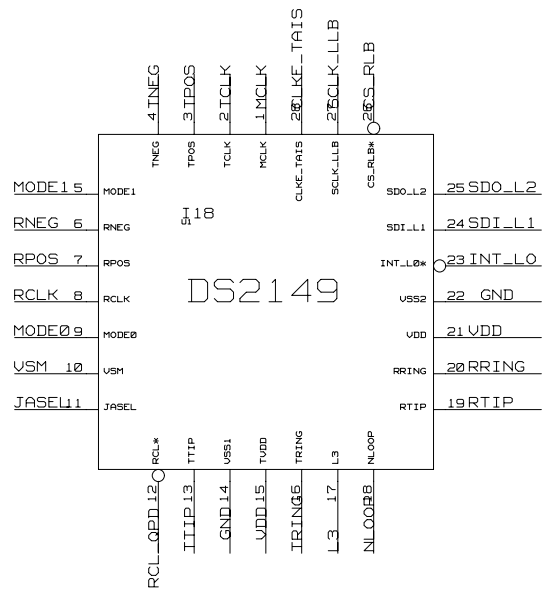

TITLE:	DEVICE PIN OUT	DATE:
ENGINEER:		PAGE: 1 OF 7



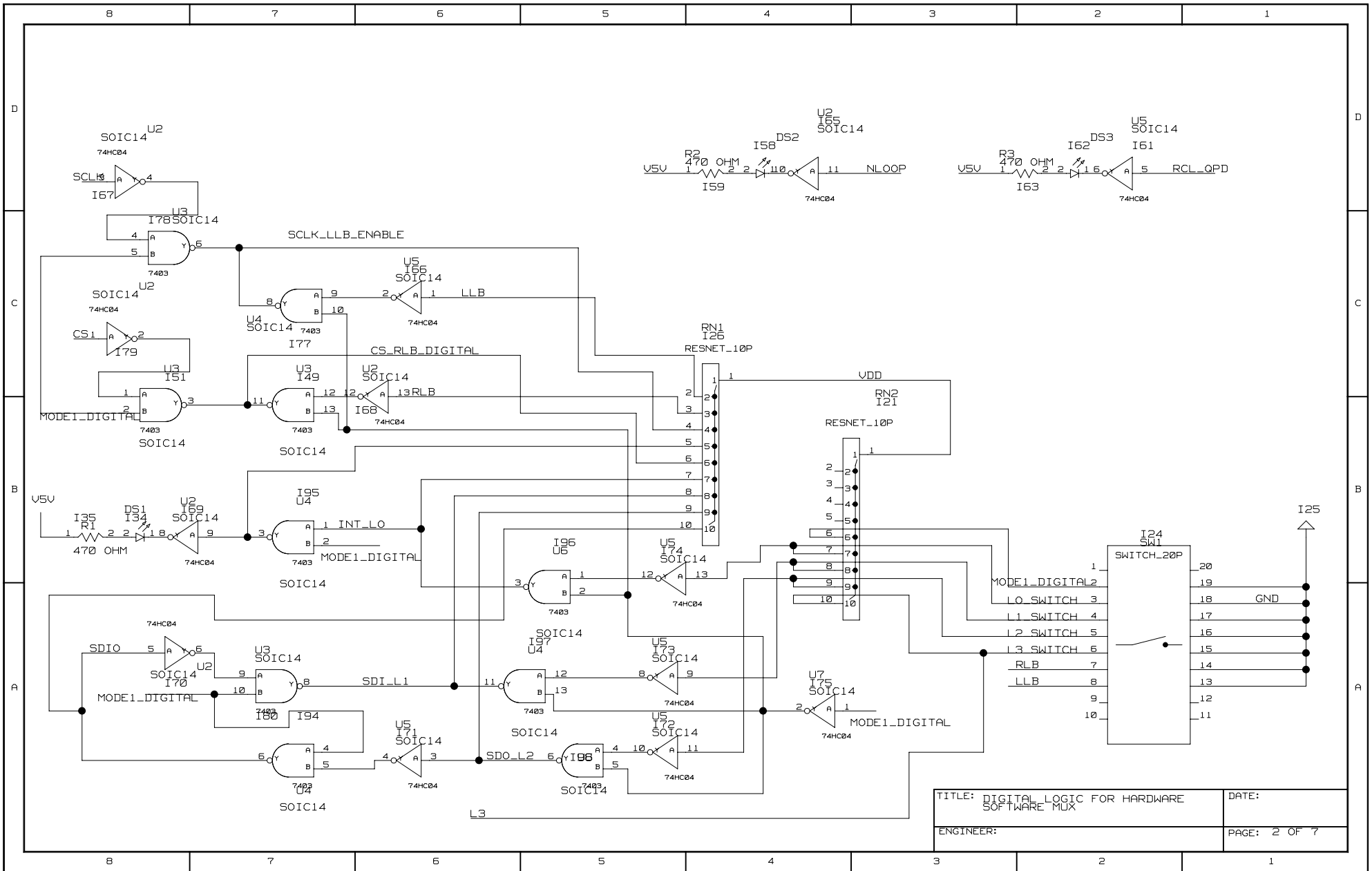

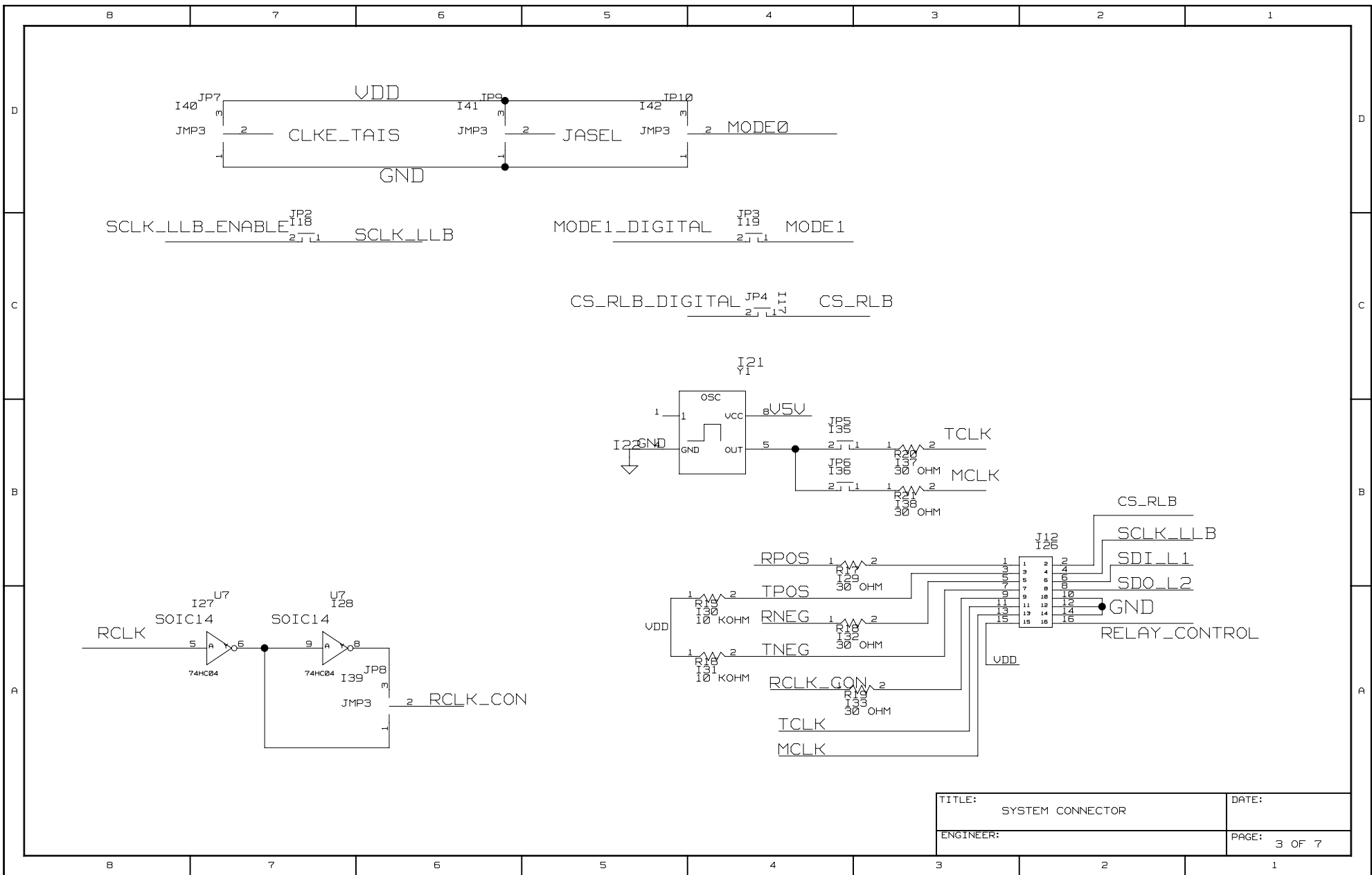

TITLE:	SYSTEM CONNECTOR	DATE:	
ENGINEER:		PAGE:	3 OF 7

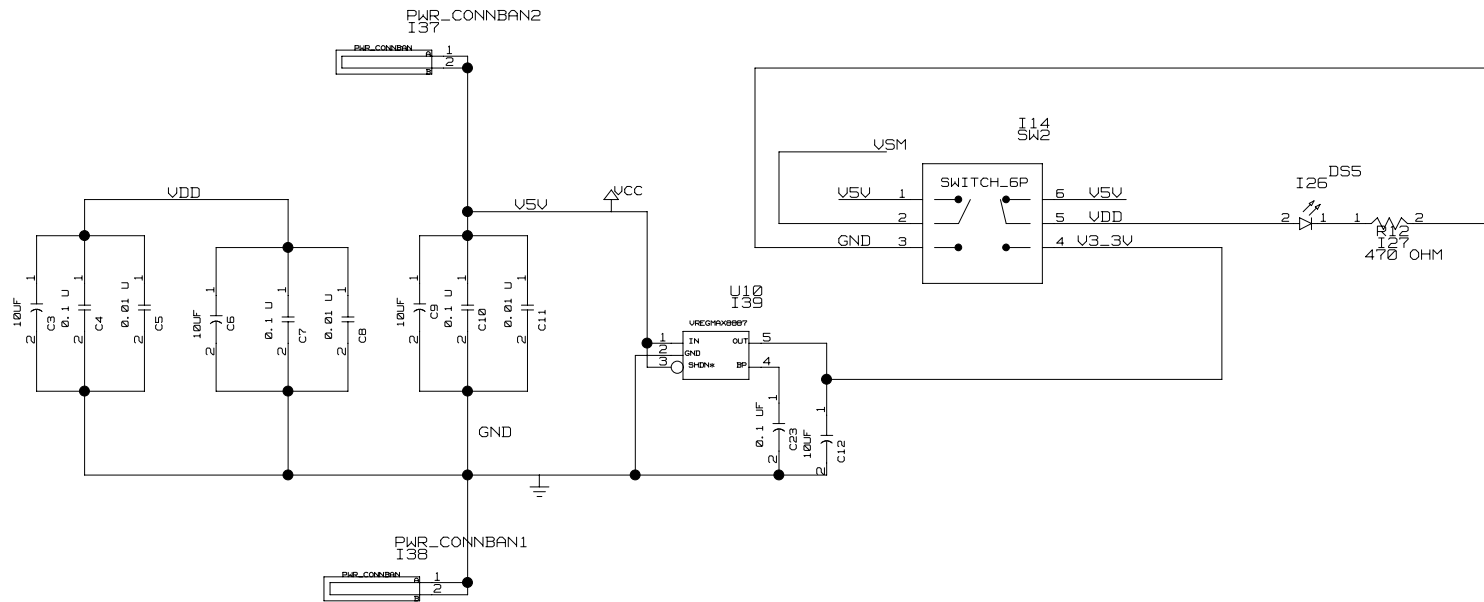

TITLE: POWER CIRCUITRY	DATE:
ENGINEER:	PAGE: 4 OF 7

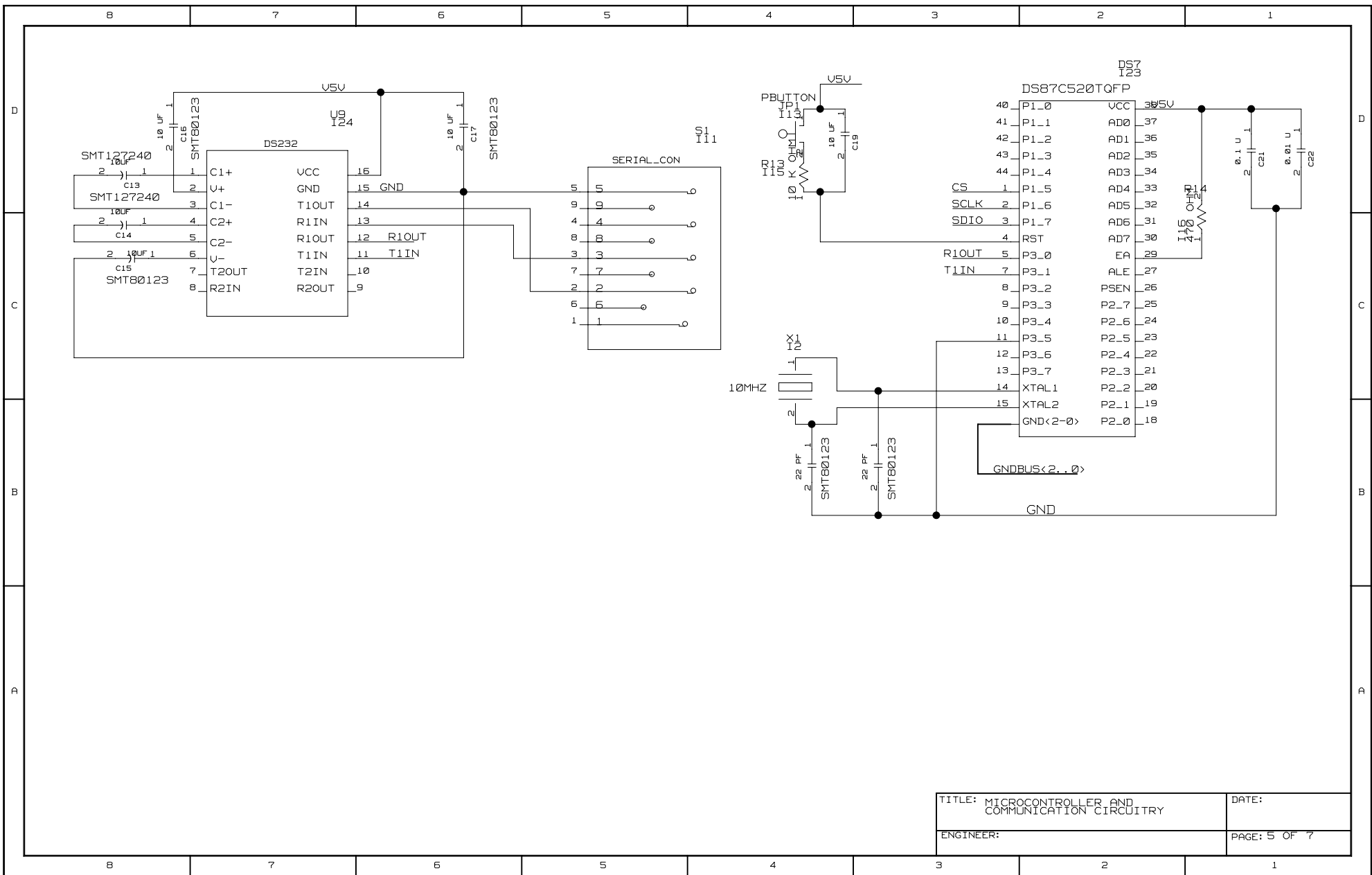

TITLE: MICROCONTROLLER AND COMMUNICATION CIRCUITRY	DATE:
ENGINEER:	PAGE: 5 OF 7

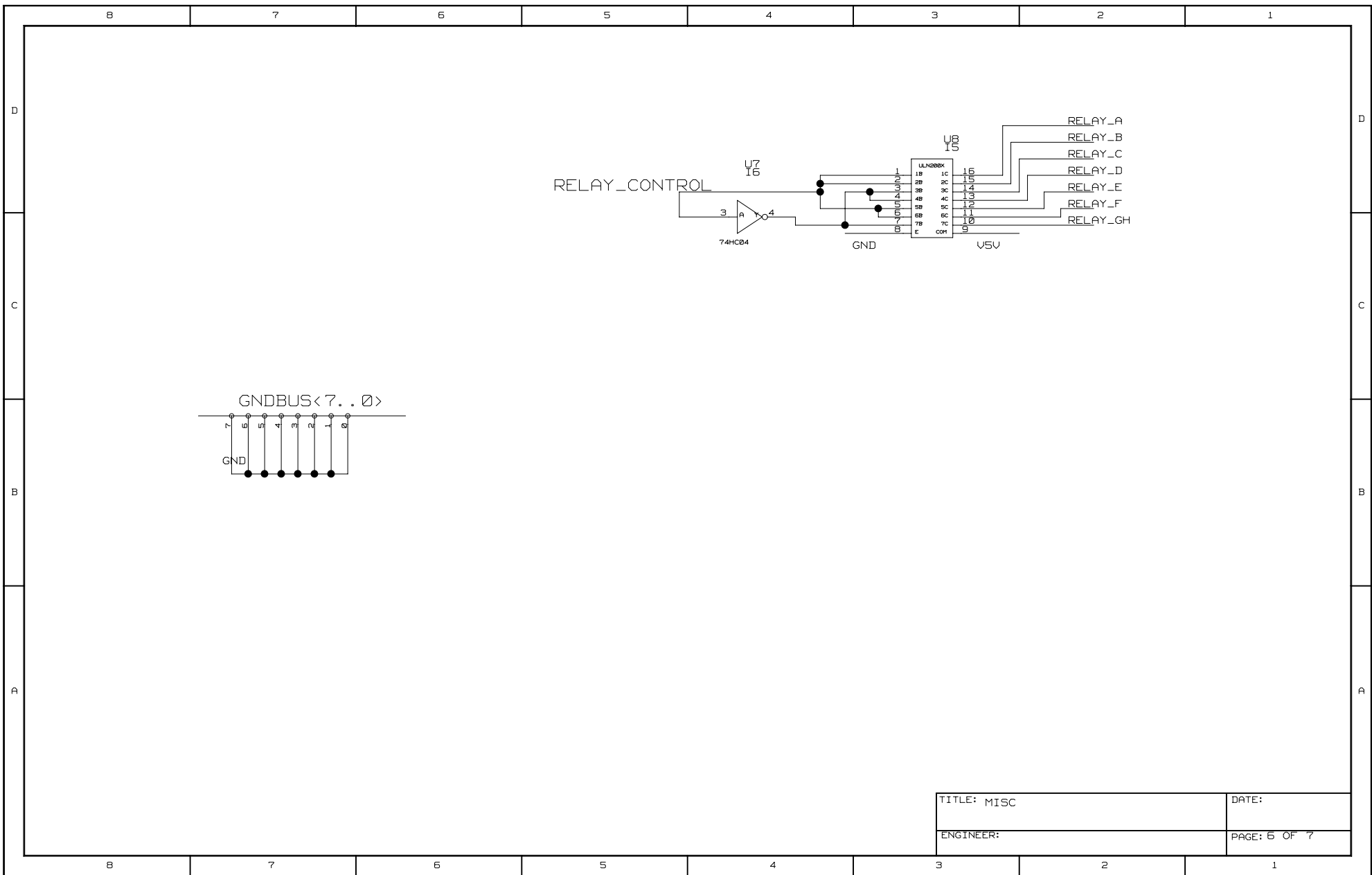

TITLE: MISC	DATE:
ENGINEER:	PAGE: 6 OF 7

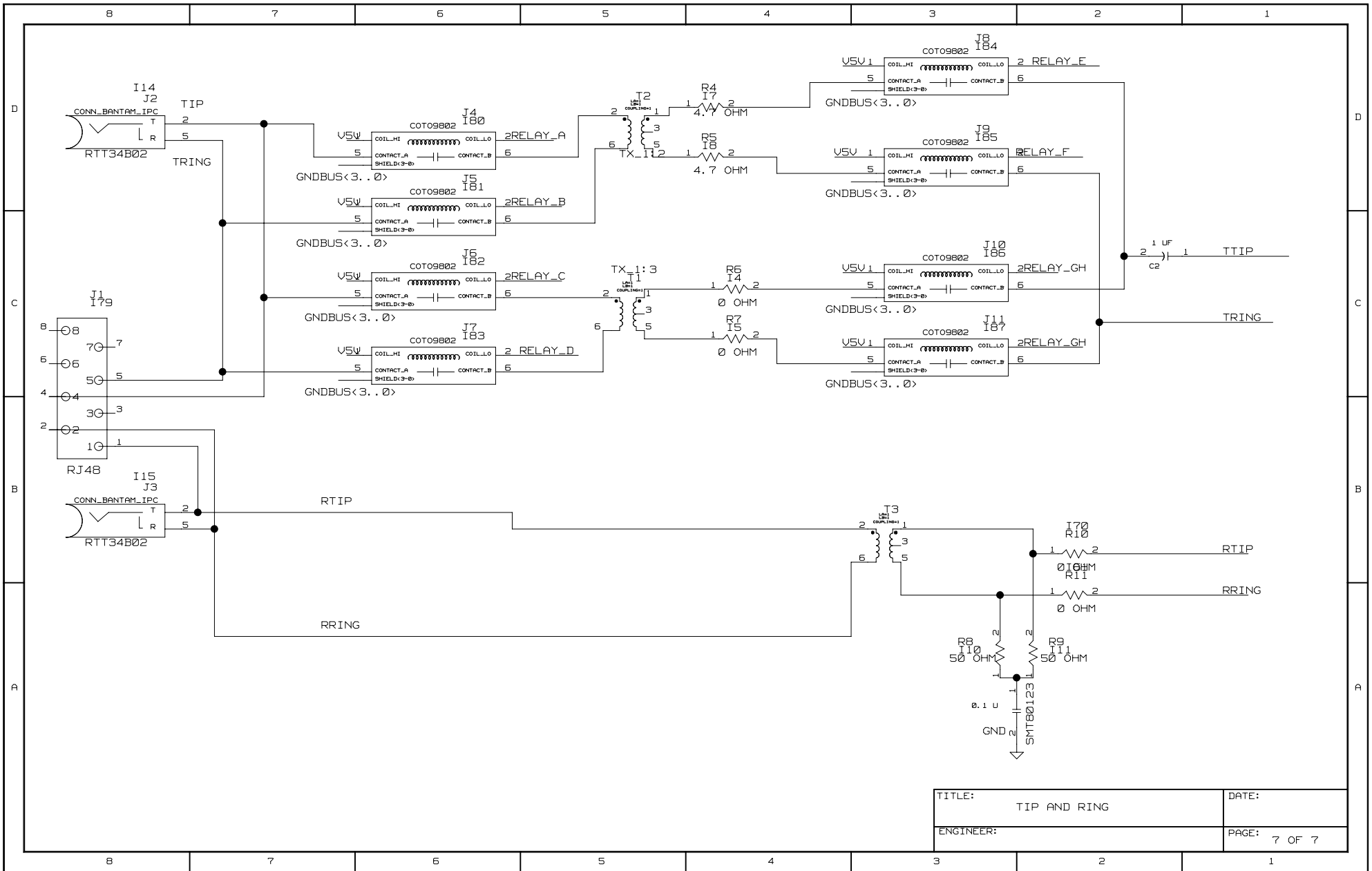

TITLE:	TIP AND RING	DATE:
ENGINEER:		PAGE: 7 OF 7