

THIS DRAWING IS UNPUBLISHED. RELEASED FOR PUBLICATION
 © COPYRIGHT - By - ALL RIGHTS RESERVED.

LOC		DIST		REVISIONS			
P	LTR	DESCRIPTION	DATE	DWN	APVD		
	H2	REVISED PER ECO-15-013197	16OCT15	KG	DM		

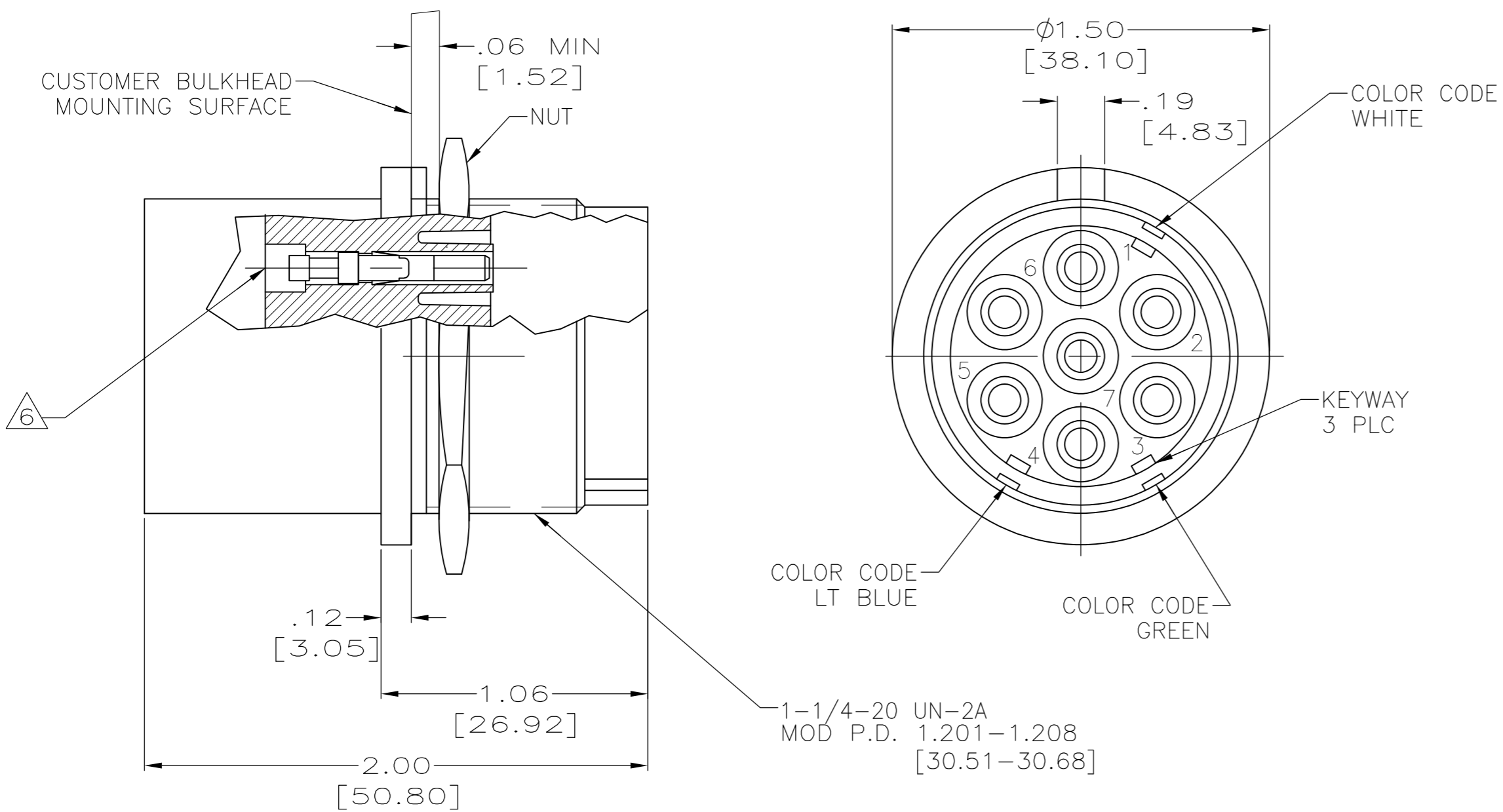

- SEVEN CONTACT CAVITIES ACCEPT TYPE II, SIZE 16 SOCKETS AND COAX CONTACTS AS SHOWN IN TABLE. EXTRACTION TOOL PART NUMBER IS 861751-1.
 - TYPE II SOCKETS TO ACCEPT 22 AWG - 24 AWG STRANDED WIRE. SOCKETS GOLD PLATED PER MIL-G-45204 TYPE II .000050 MIN THK.
 - RECEPTACLE WILL WITHSTAND WITHOUT BREAKDOWN, 27 KVDC PIN TO PIN & 27 KVDC PIN TO GRD WHEN MATED WITH 861648-1.
 - TYPE II SOCKETS TO ACCEPT ONE 16 AWG OR ONE 18 AWG STRANDED WIRE.
 - TYPE II SOCKETS TO ACCEPT 14 AWG STRANDED WIRE.
 - CUSTOMER TO ATTACH LEADS & PROTECT AGAINST ARC OVER & BREAKDOWN BY POTTING. SOCKETS TO BE COATED WITH RTV108
- △7 CRIMP CONTACTS PER TE 408-7516 AS SPECIFIED FOR EACH CONTACT PART NUMBER.

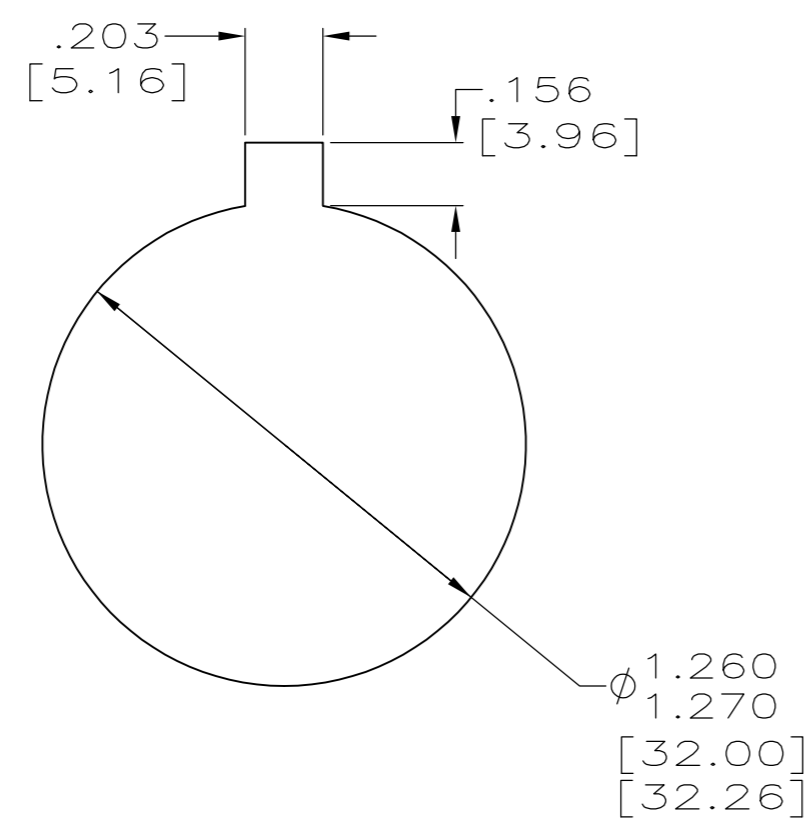

RECOMMENDED PANEL CUTOUT

CRIMP CONTACT PART NUMBER	COLOR CODING	WIRE SIZE RANGE	PART NUMBER
201568-1	NO	14	861647-9
200333-1	NO	16,18	861647-8
201328-1	NO	20,22,24	861647-7
-	YES	NO SOCKETS	861647-6
-	YES	14	861647-5
-	YES	20-24 & COAX	861647-4
201328-1	YES	20-24 & COAX	861647-3
200333-1	YES	16,18	861647-2
201328-1	YES	20,22,24	861647-1

THIS DRAWING IS A CONTROLLED DOCUMENT.

DIMENSIONS: INCHES [mm]	TOLERANCES UNLESS OTHERWISE SPECIFIED:	DWN T. THOMPSON 03-22-95	
		CHK D. EABY 04-19-95	
		APVD D. EABY 04-19-95	
		PRODUCT SPEC	
		APPLICATION SPEC	NAME RECEPTACLE, FLANGED H.V. 7 CONTACT, LGH
MATERIAL MOLDED PLASTIC	FINISH BLACK	WEIGHT -	SIZE A2 CAGE CODE 00779 DRAWING NO C=861647 RESTRICTED TO -
		CUSTOMER DRAWING	SCALE 2:1 SHEET 1 of 1 REV H2