

This document is the property of Amphenol Corporation and is delivered on the express condition that it is not to be disclosed, reproduced or used, in whole or in part, for manufacture or sale by anyone other than Amphenol Corporation without its prior consent, and that no right is granted to disclose or to use any information in this document.

The marking on this product doesn't contain environmental hazardous materials per Material Specification SS-00259 for Sony GP compliant or per directive 2011/65/EU for RoHS compliant.

FOR REFERENCE ONLY

REVISIONS				
SYM	ECN No.	DESCRIPTION	DATE	APPROVED
AX1	EDSR#6970	NON-RELEASE REVISION	12/29/2016	Roger Tsai
AX2	EDSR#7421	UPDATE DIMENSION	05/12/2017	Roger Tsai
AX3	EDSR#7616	REMOVE ROUTE KEEPOUT	07/11/2017	Roger Tsai
AX4	EDSR#7889	ADD PACKAGE	09/14/2017	Roger Tsai
AX5	EDSR#8091	ADD 30u" GOLD	11/10/2017	Roger Tsai
AX6		ADD DATE CODE/UPDATE NOTES NO.1&2/UPDATE PACKAGE	03/22/2018	Roger Tsai

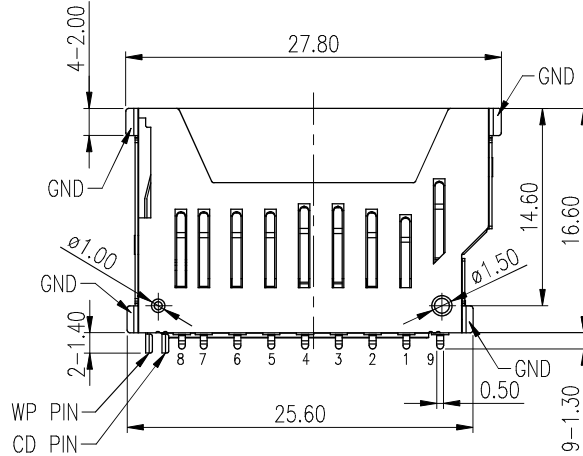
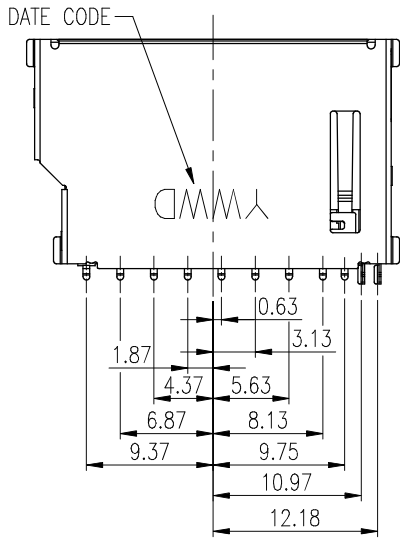
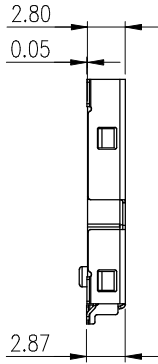
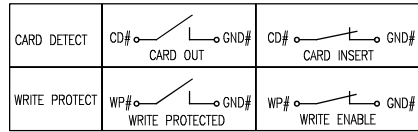
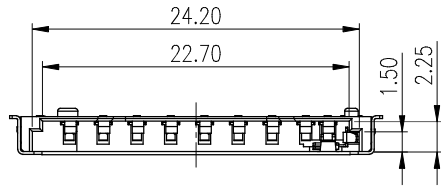

NOTES:

- MATERIAL:**
HOUSING: HIGH TEMPERATURE THERMAL PLASTIC LCP, UL94V-0, COLOR: WHITE.
TERMINAL: COPPER ALLOY.
SHELL: STAINLESS STEEL.
- FINISH:**
TERMINAL:
CONTACT AREA: GOLD PLATING OPTION;
SOLDERING AREA: MATTE TIN PLATING 100 μ" THICKNESS MIN.;
UNDER PLATING: NICKEL PLATING 50 μ" THICKNESS MIN. OVERALL.
SHELL: SOLDERABLE NICKEL 50 μ" THICKNESS MIN. OVERALL.
- THIS PRODUCT IS HALOGEN-FREE PRODUCT.

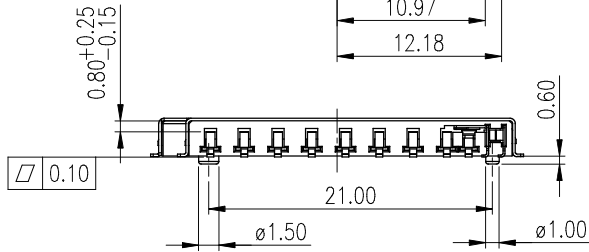

SD CARD PIN ASSIGNMENT		
Pin NO.	Name	Description
1#	CD/DAT3	Card detect/data I/O
2#	CMD	Command
3#	VSS1	Ground
4#	VDD	Power
5#	CLK	Clock
6#	VSS2	Ground
7#	DAT0	Data I/O
8#	DAT1	Data I/O
9#	DAT2	Data I/O

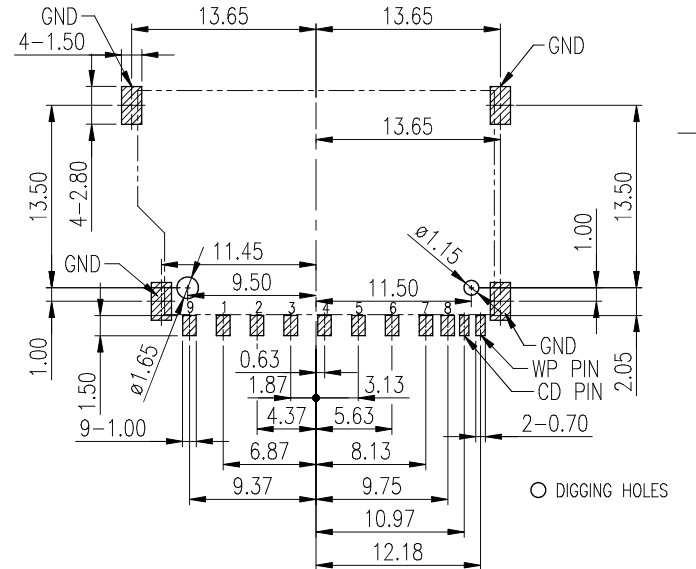

RECOMMEND P.C.BOARD LAYOUT
PCB TOLERANCE: ±0.05

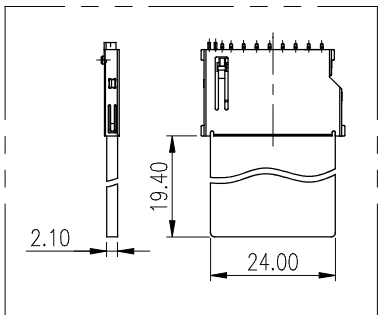

PART NO. GMC02008 X HR

CONTACT FINISH
0: GOLD FLASH
1: 5 μ" GOLD
2: 10 μ" GOLD
3: 15 μ" GOLD
4: 30 μ" GOLD

TOLERANCE	APPROVALS	DATE	TITLE
X. ±0.30	DRAWN Karen Su	03/22/2018	GMC SERIES 2 IN 1 CONN. SD+MMC
X.X ±0.20			
X.XX ±0.10	CHECKED Aqua Chou	03/22/2018	
ANGULAR ±1°	APPROVED Roger Tsai	03/22/2018	
UNLESS OTHERWISE SPECIFIED	DWG TYPE CUST DWG	PROJECT CODE OTHER	

UNIT mm		SIZE A3	PART No. GMC02008XHR
SCALE NA	SHEET 1 OF 2	DWG No. GMC02008XHR	REV. AX6

This document is the property of Amphenol Corporation and is delivered on the express condition that it is not to be disclosed, reproduced or used, in whole or in part, for manufacture or sale by anyone other than Amphenol Corporation without its prior consent, and that no right is granted to disclose or to use any information in this document.

The marking on this product doesn't contain environmental hazardous materials per Material Specification SS-00259 for Sony GP compliant or per directive 2011/65/EU for RoHS compliant.

FOR REFERENCE ONLY

REVISIONS					
SYM	ECN No.	DESCRIPTION	DATE	APPROVED	
AX1	EDSR#6970	NON-RELEASE REVISION	12/29/2016	Roger Tsai	
AX2	EDSR#7421	UPDATE DIMENSION	05/12/2017	Roger Tsai	
AX3	EDSR#7616	REMOVE ROUTE KEEPOUT	07/11/2017	Roger Tsai	
AX4	EDSR#7889	ADD PACKAGE	09/14/2017	Roger Tsai	
AX5	EDSR#8091	ADD 30u" GOLD	11/10/2017	Roger Tsai	
AX6		ADD DATE CODE/UPDATE NOTES NO.1&2/UPDATE PACKAGE	03/22/2018	Roger Tsai	

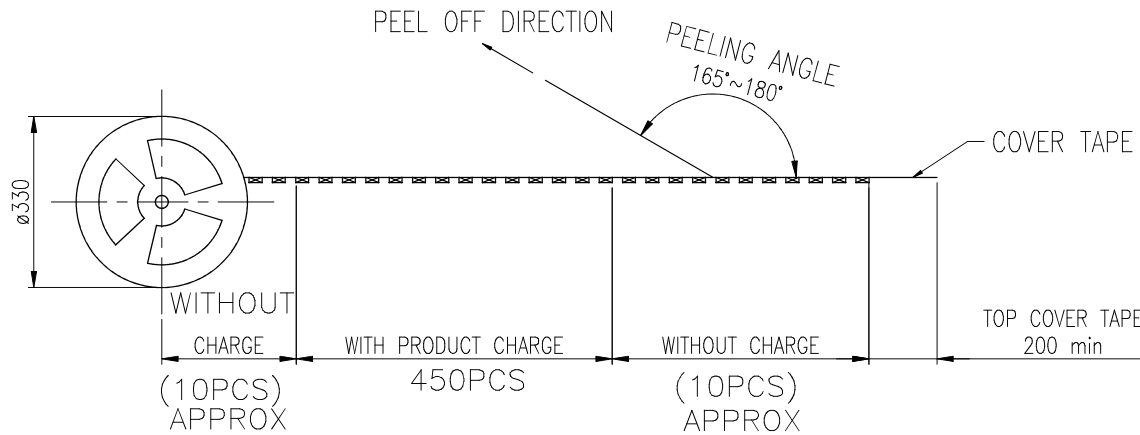

USER DIRECTION OF UNREELING

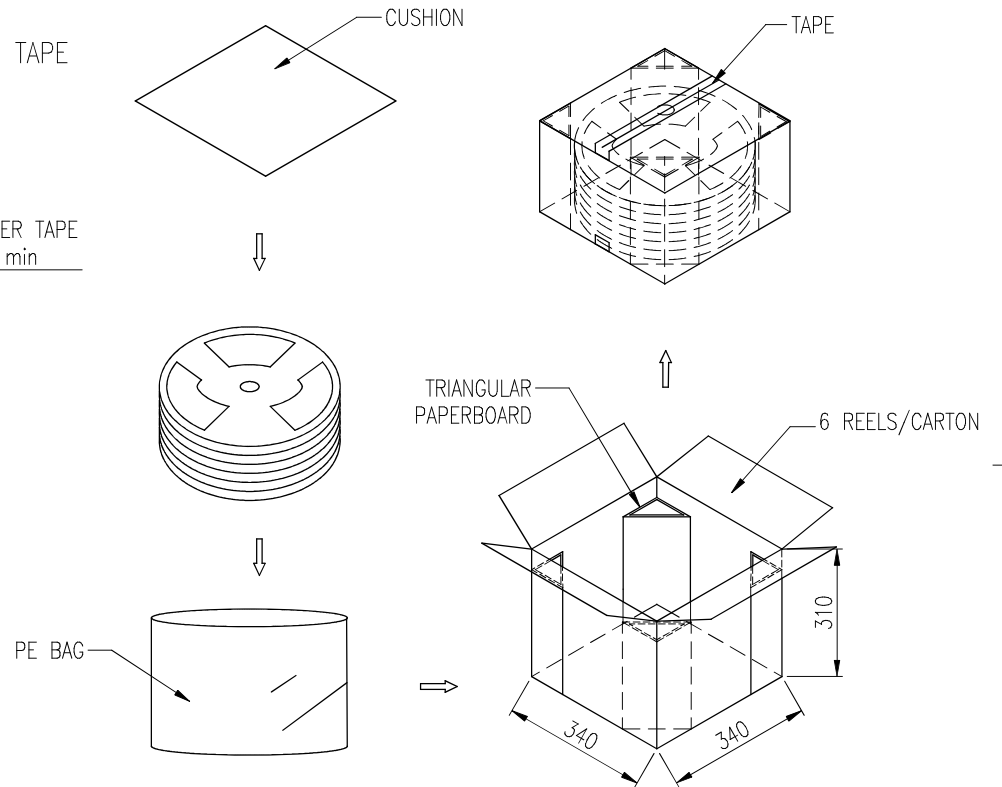
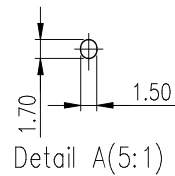
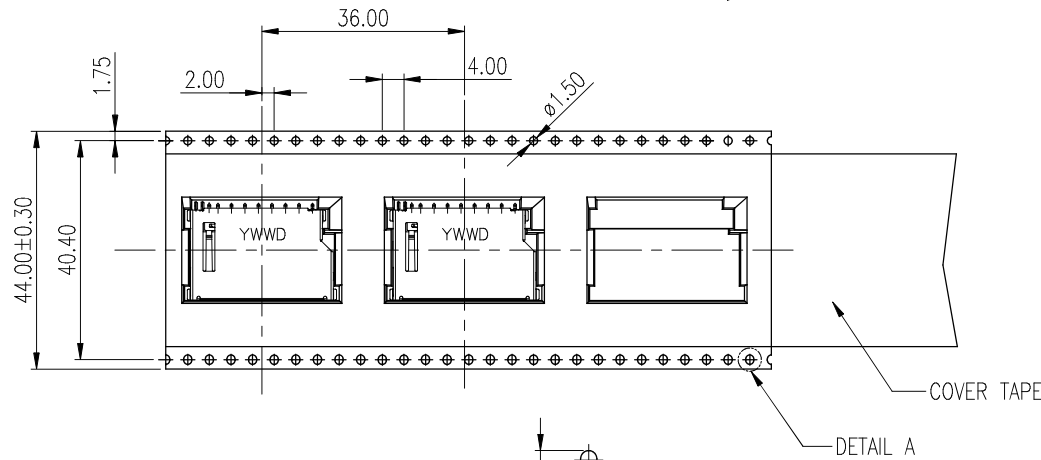

PACKAGING	9.15	7.92	450	6	2700	GMC02008XHR
BY REEL	G/W KG	N/W KG	PCS/ REEL	REELS/ CARTON	QUANTITY (PCS)	PART NUMBER

TOLERANCE	APPROVALS	DATE	TITLE		PART No.	
X. ±0.30	DRAWN Karen Su	03/22/2018	GMC SERIES 2 IN 1 CONN. SD+MMC		Amphenol [®] Amphenol Corporation Amphenol Taiwan Corporation	
X.X ±0.20	CHECKED Aqua Chou	03/22/2018				
X.XXX ±0.10	APPROVED Roger Tsai	03/22/2018				
ANGULAR ±1°	DWG TYPE CUST DWG	PROJECT CODE OTHER	UNIT mm	SIZE A3	PART No. GMC02008XHR	
UNLESS OTHERWISE SPECIFIED			SCALE NA	SHEET 2 OF 2	DWG No. GMC02008XHR	REV. AX6

