

Dual Phase Synchronous Step-Up DC/DC Converter

DESCRIPTION

Demonstration circuit 1859A is a dual phase single output DC/DC boost converter featuring the LTC[®]3124. The DC1859A operates over 1.8V to 5.5V input and generates 12V at up to 1.5A from a 5V input. The maximum output current for a 1.8V input is 750mA. Also, the LTC3124 has a 2% precise voltage reference, which can generate an output voltage with 2.2% tolerance if 0.1% voltage divider resistors are used. The 1MHz switching frequency operation results in small and efficient circuit. The converter operates with only one phase in Burst Mode[®] operation

and achieves over 90% efficiency with a 100mA load. The demonstration circuit can be easily modified to generate different output voltages.

The DC1859 has small circuit footprint. It is a high performance and cost effective solution for generating output voltages up to 15V from inputs as low as 1.8V.

Design files for this circuit board are available at <http://www.linear.com/demo/DC1859A>

LT, LT, LTC, LTM, Linear Technology, Burst Mode and the Linear logo are registered trademarks of Linear Technology Corporation. All other trademarks are the property of their respective owners.

PERFORMANCE SUMMARY Specifications are at T_A = 25°C

PARAMETER	CONDITION	MIN	TYP	MAX	UNITS
Minimum Input Voltage	I _{OUT} = 0A to 0.75A		1.8		V
Maximum Input Voltage	I _{OUT} = 0A to 1.5A		5.5		V
V _{OUT}	V _{IN} = 1.8V to 5.5V, I _{OUT} = 0A		12		V ±4%
Output Voltage Ripple	V _{IN} = 5V, I _{OUT} = 1.5A		100		mV _{p-p}
Nominal Switching Frequency			1		MHz

QUICK START PROCEDURE

Demonstration circuit 1859 is easy to set up to evaluate the performance of the LTC3124. For proper measurement equipment setup refer to Figure 1 and follow the procedure below:

NOTE: When measuring the input or output voltage ripple, care must be taken to minimize the length of oscilloscope probe ground lead. Measure the input or output voltage ripple by connecting the probe tip directly across the VIN or VOUT and GND terminals as shown in Figure 2.

1. With power off, connect the input power supply to VIN and GND.
2. Keep the load set to 0A or disconnected.

3. Turn the input power source on and slowly increase the input voltage. Be careful not to exceed 5.5V.

NOTE: Make sure that the input voltage V_{IN} does not exceed 5.5V.

4. Set the input voltage to 5V and check for the proper output voltage of 12V. If there is no output, temporarily disconnect the load to make sure that the load is not set too high.
5. Once the proper output voltage is established, adjust the load and observe the output voltage regulation, ripple voltage, efficiency and other parameters.

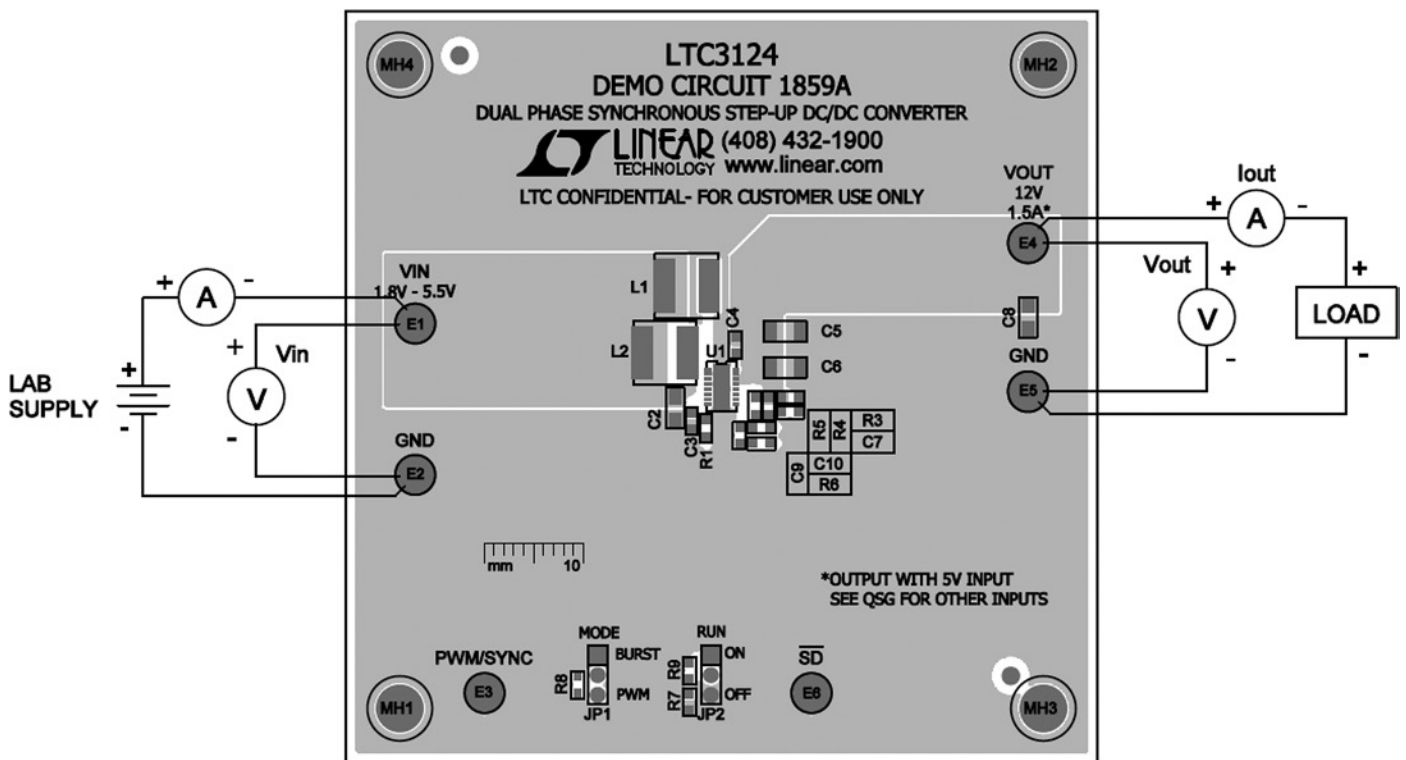

Figure 1. Proper Measurement Equipment Setup

QUICK START PROCEDURE

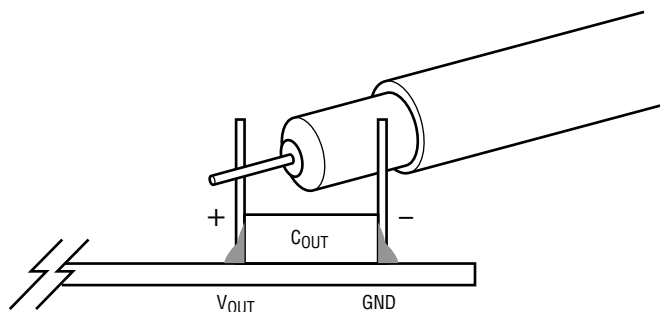

Figure 2. Measuring Input or Output Ripple

Changing the Output Voltage

To change the output voltage from the programmed 12V, change the voltage divider resistors connected to LTC3124 FB pin (see the schematic on page 5).

Converter Output Current

The DC1859 output current capability depends on the input voltage. Typical performance of DC1859A is shown in Figure 3. As can be seen from Figure 3, the maximum output current is 800mA with 2.6V input and 2A with 5V input. The efficiency is high at light loads thanks to phase shedding in BURST mode. By disabling one phase the related switching losses are reduced and the efficiency is maximized.

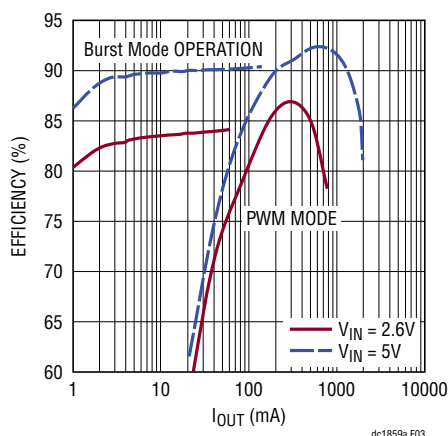

Figure 3. The Efficiency Is Maximized for Light Loads by Shedding One Phase in Burst Mode Operation. The Efficiency Is Over 90% at Higher Loads and It Reaches 92% at 800mA Load

Output Load Step Response

The load step response of DC1859A is dependent on the amount and type of output caps used. If higher load steps need to be handled more output capacitance can be added in order to keep the voltage transients at the desired level. The load step transients are shown in Figure 4. Other types of low ESR and high value capacitors can be used if space is available to reduce load transients to desired level.

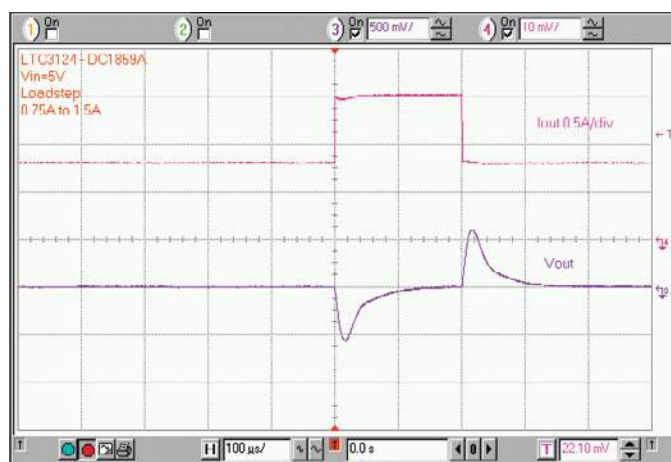

Figure 4. The LTC3124 Has Excellent Load Step Response with Small Output Capacitors Thanks to High Switching Frequency and Fast Feedback Loop Compensation

Start-Up and Soft-Start Function

The DC1859 features internal 10ms soft-start circuit that prevents input current surge at start-up. The soft-start circuit also prevents output voltage overshoot when output voltage ramp reaches regulation.

QUICK START PROCEDURE

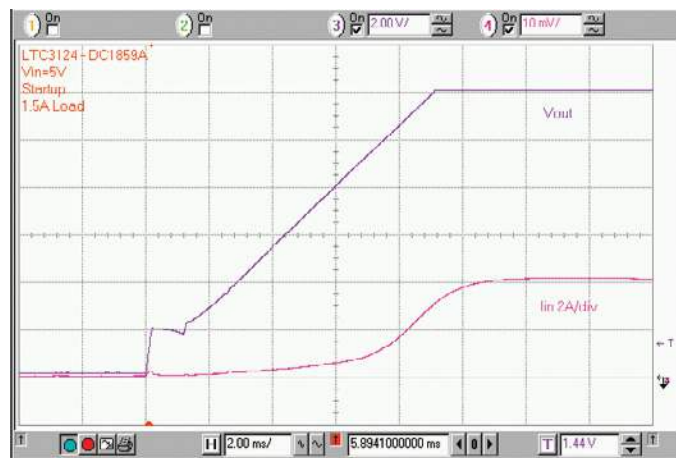

Figure 5. The DC1859 Ramps the Output Slowly at Start-Up without Generating an Input Current Surge

Output Short Circuit Protection

The LTC3124 features safe short-circuit and thermal protection. The part can operate continuously with output shorted while maintaining a maximum set current limit. The peak switch current is reduced during overload to about 2A and is restored to 3.5A once the output exceeds 1.5V.

PARTS LIST

ITEM	QTY	REFERENCE	PART DESCRIPTION	MANUFACTURER/PART NUMBER
Required Circuit Components				
2	1	C2	CAP, 0805 10 μ F 10% 10V X5R	MURATA GRM21BR61A106KE19L
3	1	C3	CAP, 0603 4.7 μ F 10% 10V X5R	AVX 0603ZD475KAT2A
4	1	C4	CAP, 0603 0.1 μ F 10% 25V X7R	AVX 06033C104KAT2A
5	2	C5, C6	CAP, 1206 22 μ F 20% 25V X5R	MURATA GRM31CR61E226ME15L
7	1	C8	CAP, 0805 1 μ F 20% 16V X5R	AVX 0805YD105MAT2A
8	1	C9	CAP, 0603 680pF 10% 25V X7R	AVX 06033C681KAT2A
9	1	C10	CAP, 0603 56pF 5% 50V COG	AVX 06035A560JAT2A
12	2	L1, L2	IND, 4.7 μ H	COILCRAFT XAL6060-472MEC
14	1	R1	RES, 0603 28k 1% 1/10W	VISHAY CRCW060328K0FKEA
16	1	R4	RES, 0603 1M 1% 1/10W	VISHAY CRCW06031M00FKEA
17	1	R5	RES, 0603 110k 1% 1/10W	VISHAY CRCW0603110KFKEA
18	1	R6	RES, 0603 51.1k 1% 1/10W	VISHAY CRCW060351K1FKEA
19	2	R8, R9	RES, 0603 1M 5% 1/10W	VISHAY CRCW06031M00JNEA
20	1	U1	IC, DC/DC CONVERTER	LINEAR TECH. LTC3124EDHC#PBF
Additional Demo Board Circuit Components				
1	0	C1, C11	CAP, 7343 OPTION	OPTION
6	0	C7	CAP, 0603 OPTION	OPTION
15	0	R3, R7	RES, 0603 OPTION	OPTION
Hardware: For Demo Board Only				
10	6	E1, E2, E3, E4, E5, E6	TURRET	MILL MAX 2501-2-00-80-00-00-07-0
11	2	JP1, JP2	HEADER, 3 PIN SINGLE ROW	SULLINS, NRPN031PAEN-RC
13	4	MH1, MH2, MH3, MH4	STANDOFF, SNAP ON	KEYSTONE_8831
21	2	JP1, JP2	SHUNT	SAMTEC 2SN-BK-G

SCHEMATIC DIAGRAM

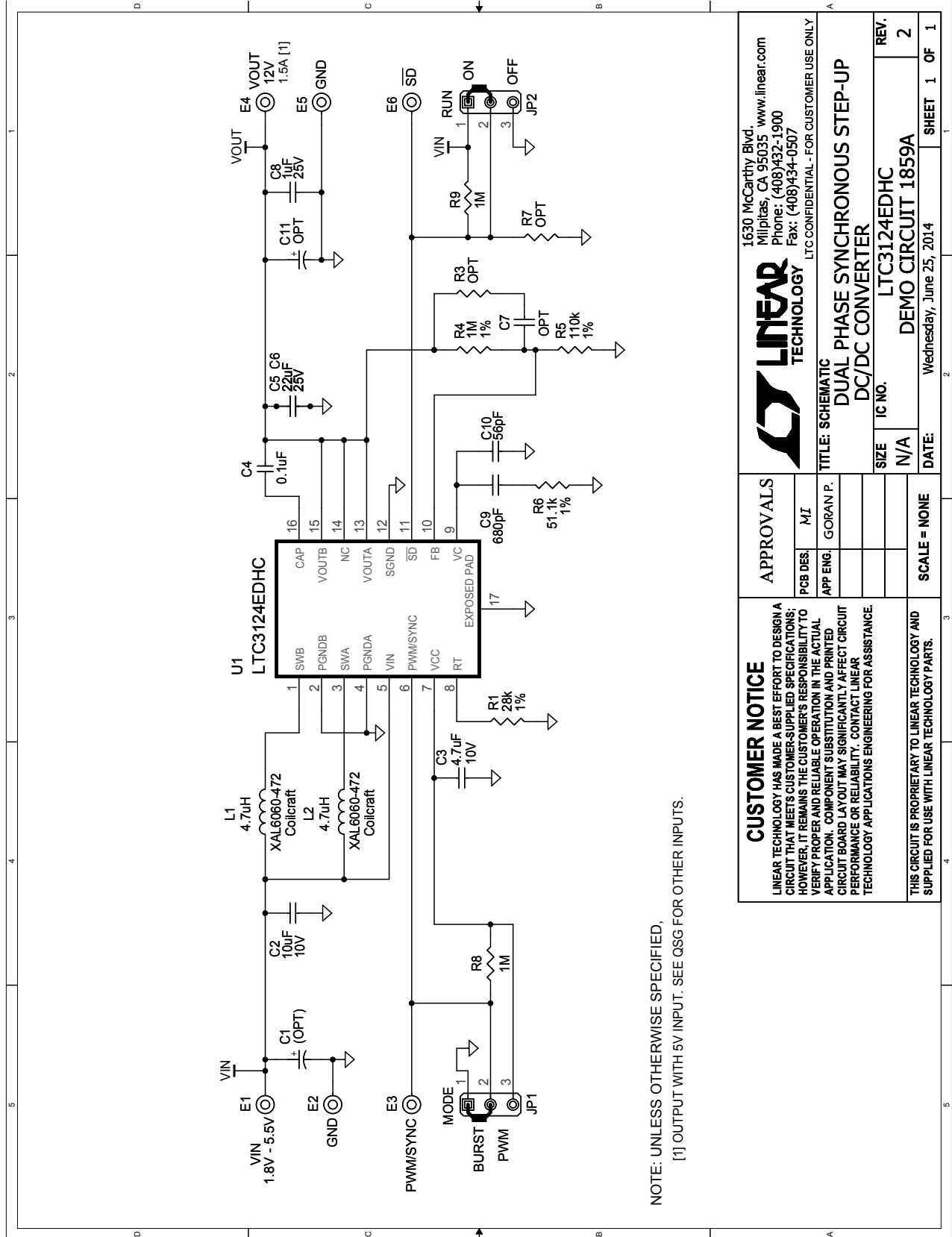

NOTE: UNLESS OTHERWISE SPECIFIED, [1] OUTPUT WITH 5V INPUT. SEE QSG FOR OTHER INPUTS.

		1630 McCarthy Blvd. Milpitas, CA 95035 www.linear.com Phone: (408)432-1900 Fax: (408)434-0507	
		LTC CONFIDENTIAL - FOR CUSTOMER USE ONLY	
APPROVALS		TITLE: SCHEMATIC	
PCB DES.	M/J	DUAL PHASE SYNCHRONOUS STEP-UP DC/DC CONVERTER	
APP ENG.	GORAN P.	SIZE	IC NO.
SCALE = NONE	NONE	N/A	LTC3124EDHC
REV.	2	DEMO CIRCUIT 1859A	
DATE:	Wednesday, June 25, 2014	SHEET	1 OF 1
CUSTOMER NOTICE LINEAR TECHNOLOGY HAS MADE A BEST EFFORT TO DESIGN A CIRCUIT THAT MEETS CUSTOMER-SUPPLIED SPECIFICATIONS; HOWEVER, IT REMAINS THE CUSTOMER'S RESPONSIBILITY TO VERIFY PROPER AND RELIABLE OPERATION IN THE ACTUAL APPLICATION. COMPONENT SUBSTITUTION AND PRINTED CIRCUIT BOARD LAYOUT MAY SIGNIFICANTLY AFFECT CIRCUIT PERFORMANCE OR RELIABILITY. CONTACT LINEAR TECHNOLOGY APPLICATIONS ENGINEERING FOR ASSISTANCE.			
THIS CIRCUIT IS PROPRIETARY TO LINEAR TECHNOLOGY AND SUPPLIED FOR USE WITH LINEAR TECHNOLOGY PARTS.			

DEMO MANUAL DC1859A

DEMONSTRATION BOARD IMPORTANT NOTICE

Linear Technology Corporation (LTC) provides the enclosed product(s) under the following **AS IS** conditions:

This demonstration board (DEMO BOARD) kit being sold or provided by Linear Technology is intended for use for **ENGINEERING DEVELOPMENT OR EVALUATION PURPOSES ONLY** and is not provided by LTC for commercial use. As such, the DEMO BOARD herein may not be complete in terms of required design-, marketing-, and/or manufacturing-related protective considerations, including but not limited to product safety measures typically found in finished commercial goods. As a prototype, this product does not fall within the scope of the European Union directive on electromagnetic compatibility and therefore may or may not meet the technical requirements of the directive, or other regulations.

If this evaluation kit does not meet the specifications recited in the DEMO BOARD manual the kit may be returned within 30 days from the date of delivery for a full refund. **THE FOREGOING WARRANTY IS THE EXCLUSIVE WARRANTY MADE BY THE SELLER TO BUYER AND IS IN LIEU OF ALL OTHER WARRANTIES, EXPRESSED, IMPLIED, OR STATUTORY, INCLUDING ANY WARRANTY OF MERCHANTABILITY OR FITNESS FOR ANY PARTICULAR PURPOSE. EXCEPT TO THE EXTENT OF THIS INDEMNITY, NEITHER PARTY SHALL BE LIABLE TO THE OTHER FOR ANY INDIRECT, SPECIAL, INCIDENTAL, OR CONSEQUENTIAL DAMAGES.**

The user assumes all responsibility and liability for proper and safe handling of the goods. Further, the user releases LTC from all claims arising from the handling or use of the goods. Due to the open construction of the product, it is the user's responsibility to take any and all appropriate precautions with regard to electrostatic discharge. Also be aware that the products herein may not be regulatory compliant or agency certified (FCC, UL, CE, etc.).

No License is granted under any patent right or other intellectual property whatsoever. **LTC assumes no liability for applications assistance, customer product design, software performance, or infringement of patents or any other intellectual property rights of any kind.**

LTC currently services a variety of customers for products around the world, and therefore this transaction **is not exclusive**.

Please read the DEMO BOARD manual prior to handling the product. Persons handling this product must have electronics training and observe good laboratory practice standards. **Common sense is encouraged.**

This notice contains important safety information about temperatures and voltages. For further safety concerns, please contact a LTC application engineer.

Mailing Address:

Linear Technology
1630 McCarthy Blvd.
Milpitas, CA 95035

Copyright © 2004, Linear Technology Corporation