

THIS DRAWING IS UNPUBLISHED.		RELEASED FOR PUBLICATION
© COPYRIGHT 19		BY AMP INCORPORATED. ALL RIGHTS RESERVED.
COMPONENT	MATERIAL	FINISH
HOUSING - COUPLING NUT	STAINLESS STEEL PER ASTM-A-484 OR ASTM-A-582 TYPE 303	GOLD PLATED PER ASTM-B-488 OVER NICKEL PER QQ-N-290
DIELECTRIC	TFE FLUORCARBON PER ASTM-D-1457	- -
CENTER CONTACT	BERYLLIUM COPPER PER ASTM-B-196 ALLOY C17300, CONDITION H	GOLD PLATED PER ASTM-B-488 OVER COPPER PER MIL-C-14550
RETAINING RING	BERYLLIUM COPPER PER ASTM-B-194 ALLOY C17200, CONDITION H	- -
GASKET	SILICONE RUBBER PER ZZ-R-765	- -

ENVIRONMENTAL	
TEMPERATURE RATING:	-65° C TO +125° C
VIBRATION:	MIL-STD-202, METHOD 204, CONDITION D
SHOCK:	MIL-STD-202, METHOD 213, CONDITION 1
MOISTURE RESISTANCE:	MIL-STD-202, METHOD 106
CORROSION:	MIL-STD-202, METHOD 101, CONDITION B. 5% SALT SPRAY
THERMAL SHOCK:	MIL-STD-202, METHOD 107, CONDITION B EXCEPT HIGH TEMP SHALL BE 155° C

MECHANICAL	
INTERFACE DIMENSIONS:	MIL-STD-348A FIG. 310.1 & 310.2
RECOMMENDED MATING TORQUE:	7-10 IN-LBS
FORCE TO ENGAGE & DISENGAGE (IN-LBS MAX.):	2.0
WEIGHT (GRAMS):	TBD
MATING CHARACTERISTICS:	INSERTION (MAX LBS): 3.0 WITHDRAWAL (MIN OZ): 1.0
COUPLING PROOF TORQUE (IN-LBS MIN)	15
COUPLING MECHANISM RETENTION FORCE (LBS MIN)	60
CENTER CONTACT CAPTIVATION:	AXIAL (LBS): 6.0 RADIAL (IN-OZ): 4.0

ELECTRICAL	
NORMAL IMPEDANCE (OHMS):	50
FREQUENCY RANGE (GHz):	DC TO 18
VOLT RATING @ SEA LEVEL (VRMS MAX):	335
VSWR:	1.05+.005f(GHz)
INSERTION LOSS: (dB MAX):	.03 √ f(GHz)
RF LEAKAGE (dB MIN):	[-60-f(GHz)]
CORONA 70,000 FT (VRMS MIN):	250
DIELECTRIC WITHSTANDING VOLTAGE (VRMS MIN) AT SEA LEVEL:	1,500
I.R. (MEGOHMS MIN):	5,000
RF HIGH POTENTIAL AT SEA LEVEL (VRMS MIN @ 5 MHz):	670
CONTACT RESISTANCE (MILLIOHMS MAX):	CENTER CONTACT: 4.0 OUTER CONTACT: 2.0 CABLE TO HOUSING: N/A

LOC	DIST	REVISIONS					
DF	XO	P	LTR	DESCRIPTION	DATE	DWN	APVD
		0		REV PER OH14-0436-04	7-04	CT	FB

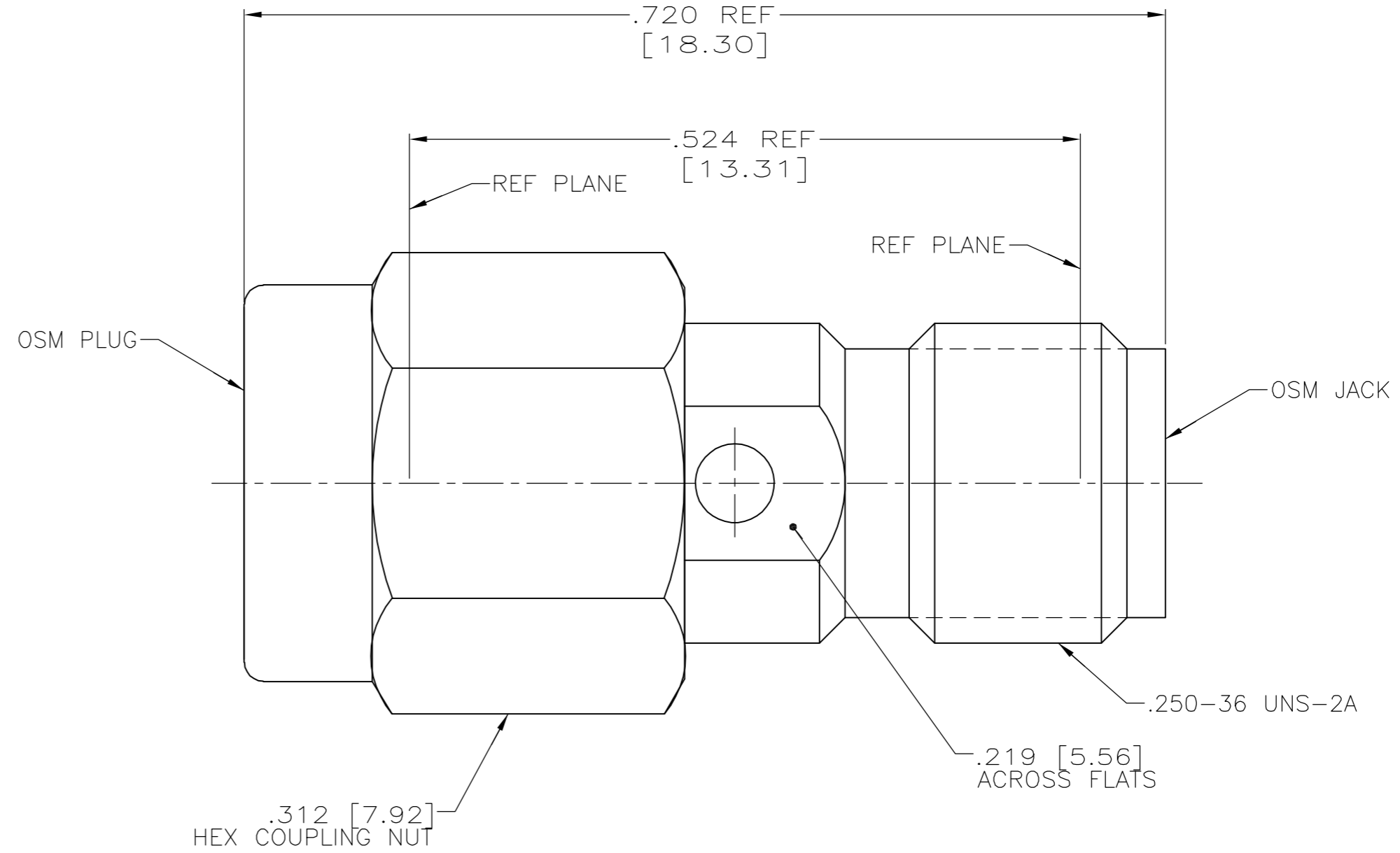

1757092-1
PART NO.

THIS DRAWING IS A CONTROLLED DOCUMENT.		DWN	C.C.THOMAS	7-16-04	tyco Electronics	TYCO Electronics Corporation Harrisburg, PA 17105-3608	AMP
DIMENSIONS: INCHES [mm]		CHK	F.BLASICK	7-19-04			
TOLERANCES UNLESS OTHERWISE SPECIFIED:		APVD	F.BLASICK	7-19-04	NAME		
0 PLC ±-		PRODUCT SPEC			SMA JACK TO SMA PLUG ADAPTER		
1 PLC ±-		USE ASSEMBLY PROCEDURE			RESTRICTED TO		
2 PLC ±-		WEIGHT			SIZE		
3 PLC ±.005 [0.13]		CAGE CODE			DRAWING NO		
4 PLC ±-		DRAWING NO			A200779		
ANGLES ±-		SCALE			10:1		
FINISH		SHEET			1 OF 1		
SEE TABLE		REV			0		
MATERIAL		CUSTOMER DRAWING					
SEE TABLE		SCALE			10:1		