



PROTEK POWER

PMP400 Medical Power Supply Series (400W)

Features:

- BF Class insulation
- Operation altitude up to 5000 meters
- Wide input range 90 to 264VAC
- Low safety ground leak age current
- Less than 300 µA leakage current
- Efficiency greater than 85%
- Overvoltage Protection
- Over-temperature Protection
- Short-Circuit Protection
- Compliant with RoHs requirements
- IEC 60601-1-2 4th Edition EMC Compliant



Description:

The PMP400 series of AC-DC switching power supplies are for 400 watts of continuous output power. They are enclosed in a 94V-0 rated polycarbonate case with an IEC 320/C14 inlet to mate with interchangeable cord for world-wide use. All models meet EN55011 class B emission limits, and are designed for medical applications.

Model ⁽²⁾	Output						Efficiency (typical) @400W 115/230 Vac
	V1	Min. Current	Max. Current At 13 CFM	Tol.	Ripple & Noise ¹	Max. Output Power	
PMP400-13-1S	18V	0A	22.23A	±5%	180mV	400W	85/88%
PMP400-14-S	24V	0A	16.67A	±5%	240mV	400W	86/89%
PMP400-15-2	28V	0A	14.29A	±5%	280mV	400W	86/89%
PMP400-17-S	36V	0A	11.12A	±5%	360mV	400W	86/89%
PMP400-18-S	48V	0A	8.34A	±5%	480mV	400W	87/89%

NOTES:

1. Ripple and noise is maximum peak to peak voltage value measured at output within 20 MHz bandwidth, at rated line voltage and output load ranges, and with a 10 µF tantalum capacitor in parallel with a 0.1 µF ceramic capacitor across the output.
2. All models are with built-in fan.



PMP400 Medical Power Supply Series (400W)

Specifications	
Safety Standards & EMC Specifications	
Safety Standards Approval	UL ES 60601-1, CSA C22.2 No. 60601-1 File No. E178020 TÜV EN 60601-1
EMI Standard	EN55011/EN55022, FCC, and VCCI Class B (radiated and conducted)
EMC Performance	EN61000-3-2: Harmonic distortion, Class A and D EN61000-3-3: Line flicker EN61000-4-2: ESD, ± 15 KV air and ± 8 KV contact EN61000-4-3: Radiated immunity, 10V/m EN61000-4-4: Fast transient/burst, ± 2 KV EN61000-4-5: Surge, ± 1 KV diff., ± 2 KV com. EN61000-4-6: Conducted immunity, 10Vrms EN61000-4-8: Magnetic field immunity, 30 A/m EN61000-4-11: Voltage dip immunity, 30% reduction for 500ms, and 100% reduction for 10ms
*Consult with TT Electronics for information on additional country safety approvals	
Input Specifications	
Input Voltage Range	90 to 264VAC
Input Frequency Range	47 to 63Hz
Input Current	4.2A (rms) for 115 VAC, 60Hz 2.1A (rms) for 230 VAC, 50Hz
Earth Leakage Current	300 μ A max. @ 264VAC, 63Hz
Touch Current	100 μ A max. @ 264 VAC, 63Hz
Output Specifications	
Ripple & Noise	1% peak to peak maximum
Overvoltage Protection	Set at 115-140% of nominal output voltage
Overcurrent Protection	Protected to output short circuit conditions
Thermal Shutdown	Protected to over temperature conditions
Temperature Coefficient	All outputs $\pm 0.04\%$ /°C maximum
Transient Response	Maximum excursion of 4% or better on all models, recovering to 1% of final value within 500 us after a 25% step load change
Environmental Specifications	
Operating Temperature	-10°C to +60°C (see derating)
Storage Temperature	-40°C to +85°C
Relative Humidity	5% to 95% non-condensing
Temperature Derating	Derate from 100% at +40°C, Linearly to 50% at +60°C
General Specifications	
Switching Frequency	85KHz Typical
Power Factor	>0.9
Efficiency	85% min. at 115 VAC or 230 VAC
Hold-up Time	12ms minimum at 110 VAC & 400W
Line Regulation	$\pm 0.5\%$ maximum at full load
Inrush Current	20A @ 115VAC or 40A @ 230VAC, at 25°C cold start
Withstand Voltage	4000 VAC from input to output (2 MOPP) 1500 VAC from input to ground (1 MOPP) 1500 VAC from output to ground
MTBF	350,000 hours at full load at 25°C ambient, calculated per MIL-HDBK-217F, excluding DC fan



PMP400 Medical Power Supply Series (400W)

Diagrams

MECHANICAL SPECIFICATIONS

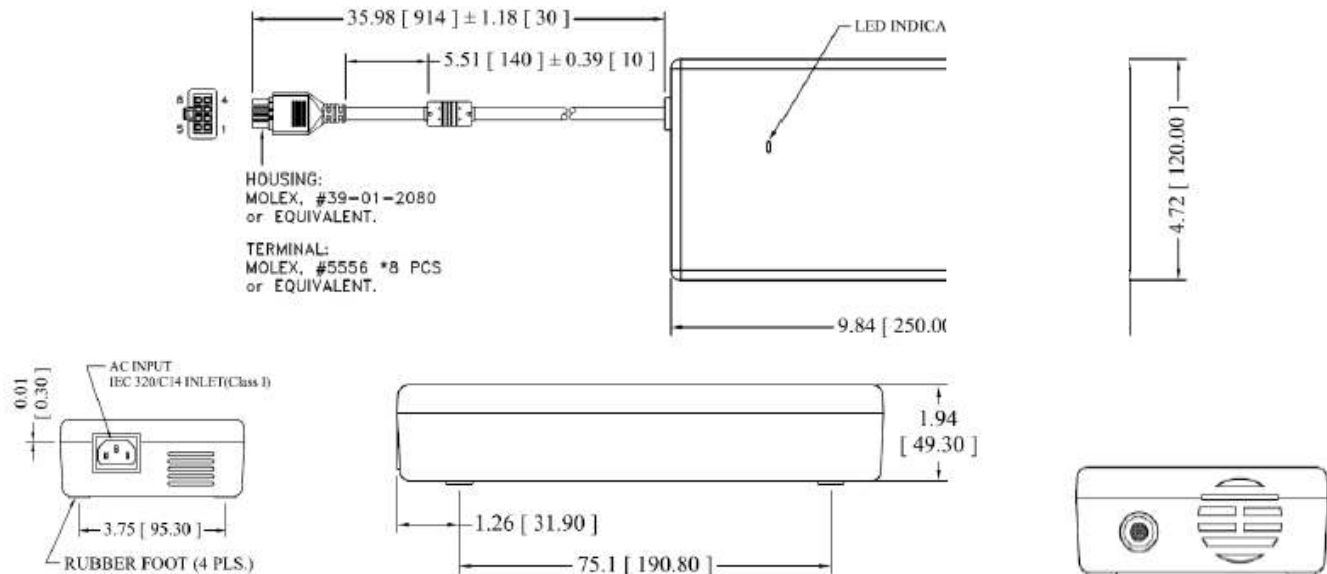

NOTES:

1. Dimensions shown in inches [mm]
2. Tolerance 0.02 [0.5] maximum
3. Weight: 1.5 Kg (3.28 lbs.) approx.
4. Output connector is Molex Mini - Fit receptacle, P/N: 39-01-2080 with female terminal #5556 or equivalent, mating with Molex plug 39-01-2086 and male terminal #5558 or equivalent. It also mates with Molex headers #5566, #5569, or equivalent.

PIN CHART

PIN NO.	1	2	3	4	5	6	7	8
Polarity	+V1				V1 Return			

OUTPUT POWER DERATING CURVE

