

## 400G QSFP-DD to 2x200G QSFP56 Breakout Active Optical Cable

### FEATURES

- Eight-channel full duplex active optical cable with breakout from QSFP-DD to 2x QSFP56
- Up to 53.125 Gbps data rate per channel by PAM 4 modulation
- Low power consumption: < 8 W on QSFP-DD end, < 4 W on QSFP56 end
- Single 3.3 V power supply
- Maximum link length of 70m on OM3 or 100m on OM4
- Management interface compliant with CMIS 4.0
- Hot pluggable QSFP-DD and QSFP56 form factors
- Commercial operating case temperature range: 0 to 70°C
- RoHS compliant

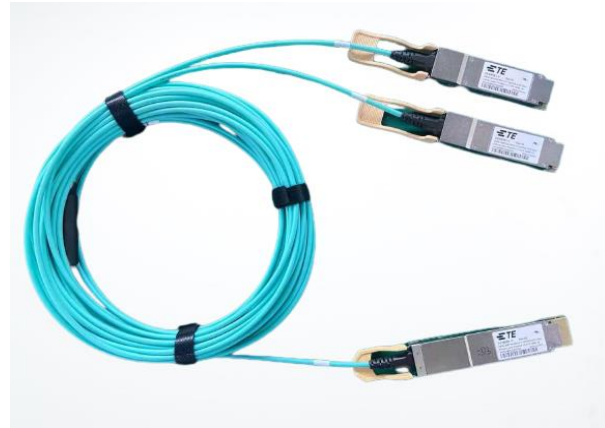

### APPLICATION

- 200G/400G Ethernet

### PRODUCT SELECTION

Parameter	Length (m)
2418081-1	1
2418081-2	2
2418081-3	3
2418081-4	5
2418081-5	10
2418081-6	15
2418081-7	20
2418081-8	30
Note: For availability of additional cable lengths, please contact TE.	

## 1. ABSOLUTE MAXIMUM RATINGS

Parameter	Symbol	Min	Max	Unit
Power Supply Voltage	Vcc	-0.5	3.6	V
Storage Temperature	Tst	-40	85	°C
Case Operating Temperature	Top	0	70	°C
Relative Humidity (non-condensing)	RH	0	85	%

## 2. RECOMMENDED OPERATING CONDITIONS

Parameter	Symbol	Min	Typ	Max	Unit	Note
Power Supply Voltage	VCC	3.135	3.3	3.465	V	
Power Supply Current	ICC	-	-	2.56	A	QSFP-DD end
		-	-	1.28	A	per QSFP56 end
Power Dissipation	P	-	-	8	W	QSFP-DD end
		-	-	4	W	per QSFP56 end
Bit Rate	BR	-	26.5625	-	Gbd	each channel

## 3. GENERAL PRODUCT CHARACTERISTICS

Parameter	Value	Notes
Module Form Factor	QSFP-DD and QSFP56	
Number of Lanes	8 Tx and 8 Rx	
Maximum Aggregate Data Rate	425 Gbps	
Maximum Data Rate per Lane	26.5625 Gbd	
Bit Error Ratio, Pre-FEC	$2.4 \times 10^{-4}$	Tested with PRBS31
Standard Cable Lengths	1, 2, 3, 5, 10, 15, 20, 30	Other lengths may be available upon request
Electrical Interface and Pin-out	QSFP-DD: 76-pin edge connector	Pin-out as defined by QSFP-DD MSA Hardware Specification
	QSFP56: 38-pin edge connector	Pin-out as defined by QSFP MSA SFF-8679
Standard Optical Cable Type	Multimode round fiber cable, OFNR and Low Smoke Zero Halogen (LSZH)	OFNP rated cable may be available upon request
Maximum Power Consumption per Cable End	8 W on QSFP-DD end 4 W on QSFP56 end	
Management Interface	Serial, I2C-based, 400kHz maximum frequency	As defined by CMIS 4.0

#### 4. ELECTRICAL CHARACTERISTICS

Low speed electrical specifications for QSFP-DD end are compliant with QSFP-DD MSA Hardware Specification. Low speed electrical specifications for QSFP56 end are compliant with SFF-8679 clause 5.

High speed electrical specifications are compliant with IEEE802.3bs Annex 120E over operating case temperature 0 to 70°C and VCC 3.3 ± 5% Volts.

Parameter	Min	Max	Unit	Note
<b>Module Electrical Input</b>				
Differential pk-pk input voltage tolerance	900	-	mV	1
Differential input return loss	IEEE802.3bm Equation (83E-5)		dB	
Differential-to-common-mode input return loss	IEEE802.3bm Equation (83E-6)		dB	
Differential termination mismatch	-	10	%	
Module stressed input test	IEEE802.3bs 120E.3.4.1			2
Single-ended voltage tolerance range				
DC common-mode voltage	-350	2850	mV	3
<b>Module Electrical Output</b>				
AC common-mode output voltage (RMS)	-	17.5	mV	
Differential peak-to-peak output voltage	-	900	mV	
Near-end ESMW (Eye symmetry mask width)	0.265	-	UI	
Near-end Eye height, differential	70	-	mV	
Far-end ESMW (Eye symmetry mask width)	0.2		UI	
Far-end Eye height, differential	30		mV	
Far-end pre-cursor ISI ratio	-4.5	2.5	%	
Differential output return loss	IEEE802.3bm Equation (83E-2)		dB	
Common-to-differential-mode output return loss	IEEE802.3bm Equation (83E-3)		dB	
Differential termination mismatch		10	10%	
Transition time (20% to 80%)	9.5		ps	
DC common-mode voltage	-350	2850	mV	3
Notes:				
1. The pattern is PRBS31Q or scrambled idle				
2. Meets specified BER				
3. DC common-mode voltage generated by the host. Specification includes effects of ground offset voltage				

**5. PIN ASSIGNMENT**

Pin assignment for QSFP-DD end is compliant with QSFP-DD MSA Hardware Specification.  
 Pin assignment for QSFP56 end is compliant with SFF-8679.

**6. MEMORY MAP**

The memory map is compatible with CMIS 4.0, and customization can be supported.

**7. MECHANICAL SPECIFICATIONS**

Unit: mm

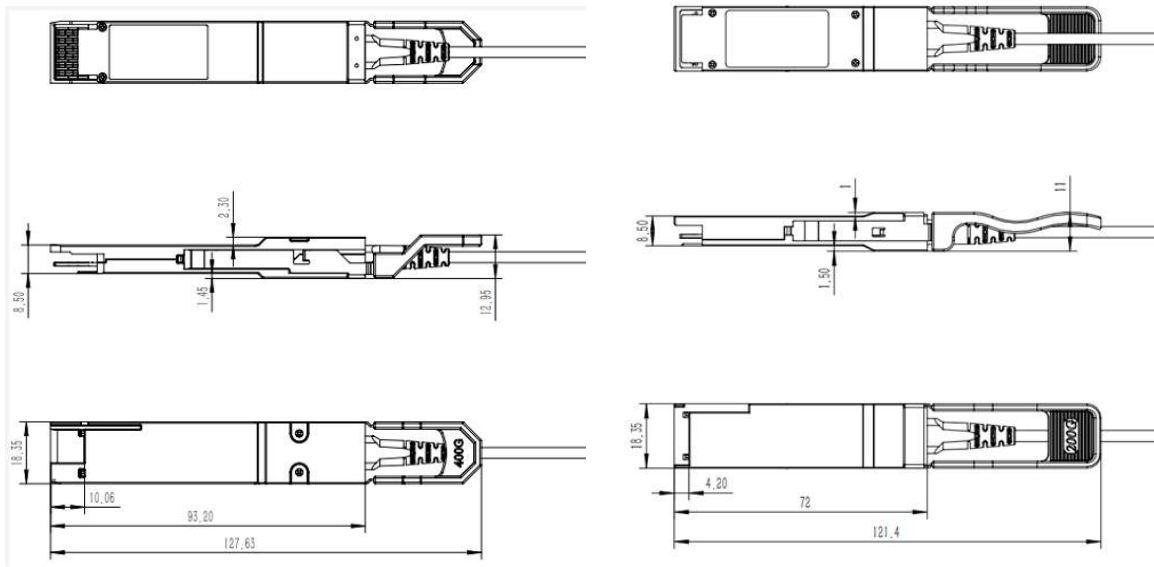

QSFP-DD end

QSFP56 end