

### Features

- IEEE 802.3 Ethernet compatible
- Fully integrated for adapter, hub and motherboard applications
- Extended temperature range: -40 to +85 °C
- AEC-Q200 Qualified, automotive grade
- RoHS compliant\*

### Applications

- Automotive
- LAN
- Ethernet

## PT61018AAPL - 10/100 Base-T Transformer

#### Electrical Specifications @ 25 °C

Inductance - OCL  
 ..... 350  $\mu$ H min. @ 100 kHz,  
 0.1 Vrms, 8 mA DC Bias

Turns Ratio ( $\pm 5\%$ ) .....1CT\*:1CT\*

DCR..... 1.2  $\Omega$  Max.

Insertion Loss  
 1-100 MHz ..... -1.15 dB Max.

Return Loss  
 1-30 MHz ..... -18 dB Min.  
 30-60 MHz ..... -13 dB Min.  
 60-80 MHz ..... -12 dB Min.

Common Mode Rejection  
 1-60 MHz ..... -37 dB Min.  
 60-100 MHz ..... -28 dB Min.

Cross Talk  
 1-60 MHz ..... -40 dB Min.  
 60-100 MHz ..... -35 dB Min.

Hipot  
 @1 mA, 60 sec. .... 1.5k Vrms

Operating Temperature ..... -40 to +85 °C

Storage Temperature..... -40 to +125 °C

\*CT: Center tap

#### Material

Termination.....Cu/Ni/Sn

#### Packaging Specifications

Tape & Reel ..... 600 pcs./reel

#### How To Order

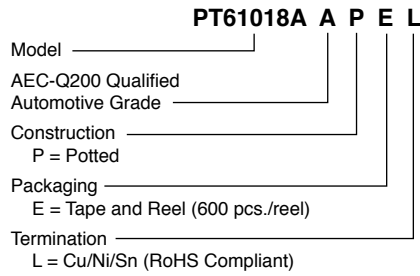

**Asia-Pacific:**  
 Tel: +886-2 2562-4117  
 Email: asiacus@bourns.com

**Europe:**  
 Tel: +36 88 520 390  
 Email: eurocus@bourns.com

**The Americas:**  
 Tel: +1-951 781-5500  
 Email: americus@bourns.com

**www.bourns.com**

#### Product Dimensions

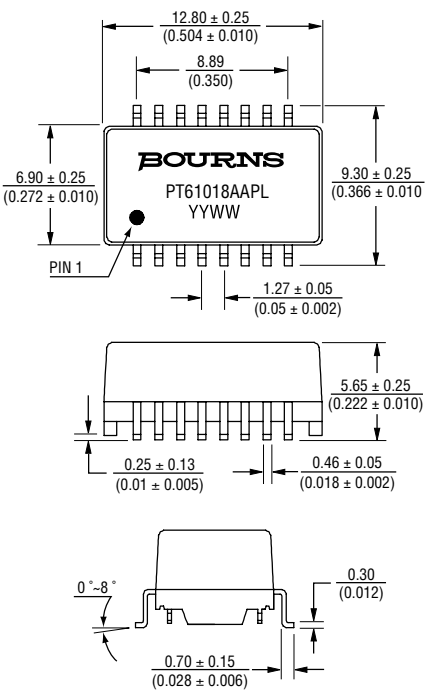

#### Recommended Layout

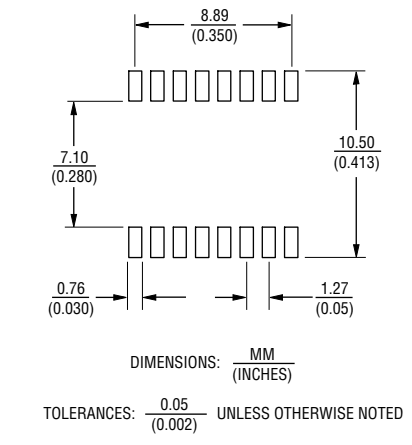

#### Electrical Schematic

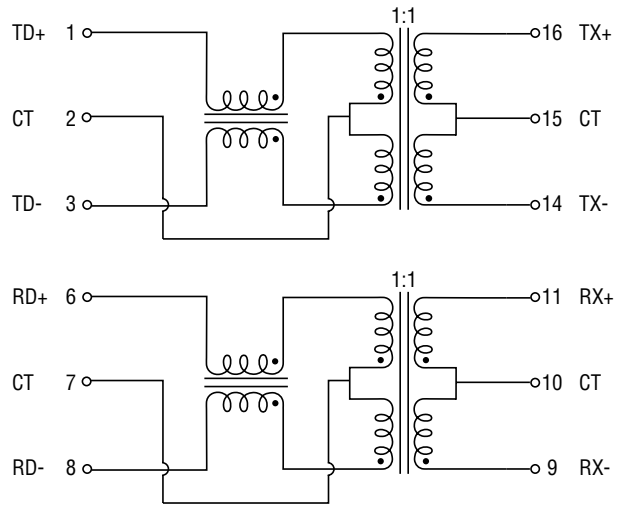

\*RoHS Directive 2002/95/EC Jan. 27, 2003 including annex and RoHS Recast 2011/65/EU June 8, 2011. Specifications are subject to change without notice. The device characteristics and parameters in this data sheet can and do vary in different applications and actual device performance may vary over time. Users should verify actual device performance in their specific applications.

# PT61018AAPEL - 10/100 Base-T Transformer



## Solder Profile

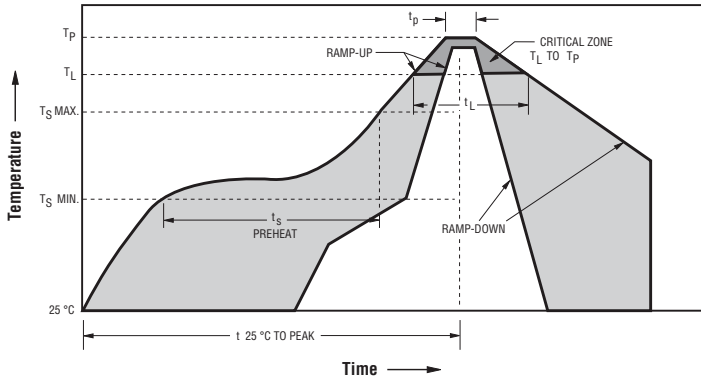

Ramp-up rate = 3 °C/sec. max.  
 Ramp-down rate = 6 °C/sec. max.  
 $T_L = 217\text{ }^{\circ}\text{C}$     $t_L = 60\text{-}150\text{ sec.}$   
 $T_p = 245\text{ }^{\circ}\text{C} \pm 5\text{ }^{\circ}\text{C}$   
 Time within 5 °C of actual Peak Temp ( $t_p$ ) = 20-40 sec.  
 $T_s \text{ min} = 150\text{ }^{\circ}\text{C}$     $T_s \text{ max} = 200\text{ }^{\circ}\text{C}$   
 $T_s \text{ min to } T_s \text{ max} = 60\text{-}180\text{ sec., } 25\text{ }^{\circ}\text{C to Peak Temperature} = 6\text{ min. max.}$

## Packaging Specifications

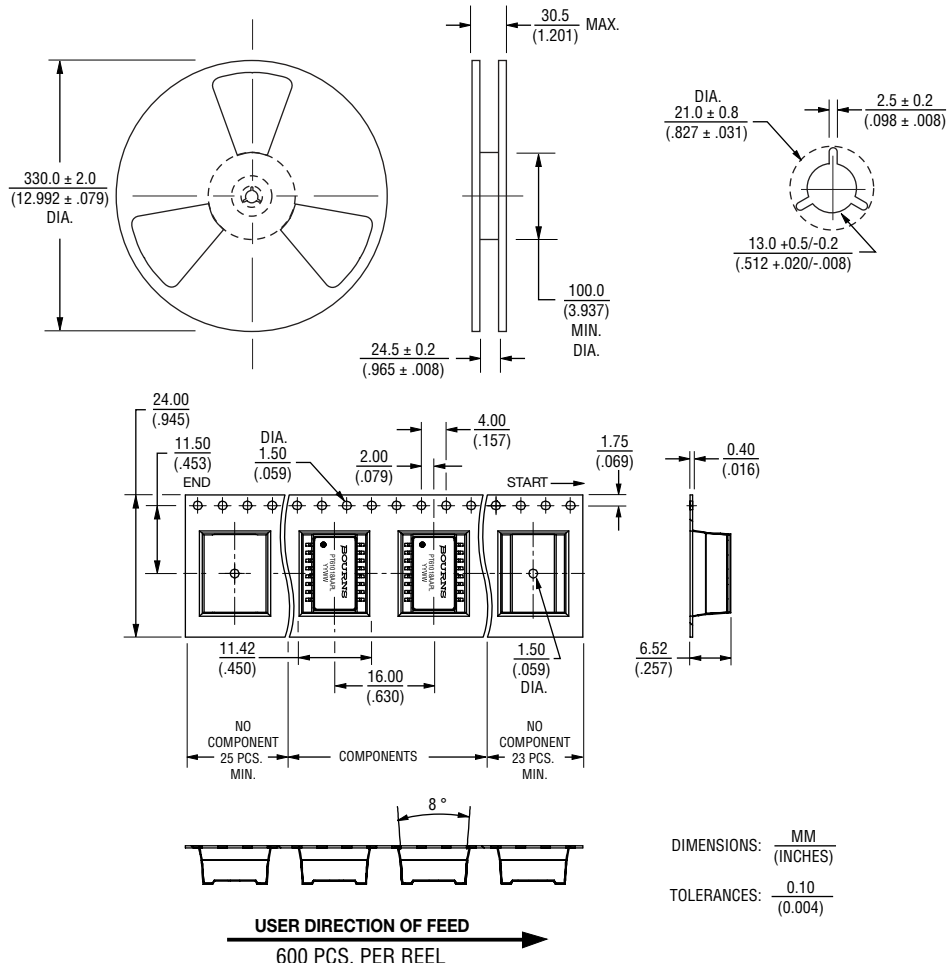

DIMENSIONS:  $\frac{\text{MM}}{\text{(INCHES)}}$   
 TOLERANCES:  $\frac{0.10}{(0.004)}$