

THIS DRAWING IS UNPUBLISHED. RELEASED FOR PUBLICATION
 © COPYRIGHT BY TYCO ELECTRONICS CORPORATION. ALL RIGHTS RESERVED.

Loc		DIST		REVISIONS			
P	LTR	DESCRIPTION		DATE	DWN	APVD	
		01		REVISED PER ECO-06-029986	22DEC2006	KS	JL

1. SEE IS 2299-3

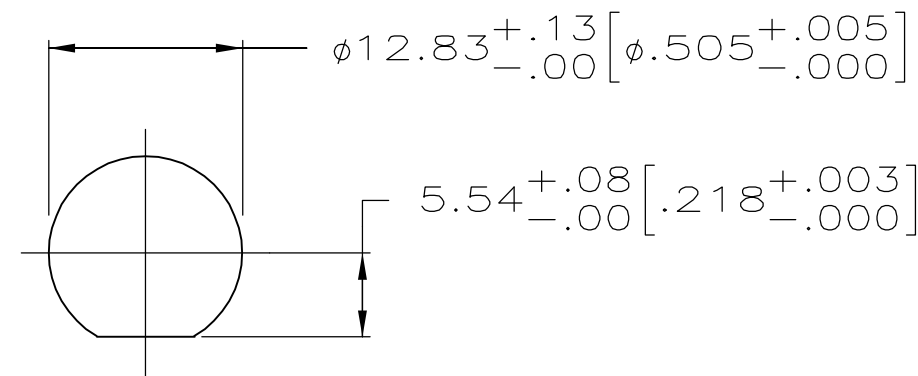
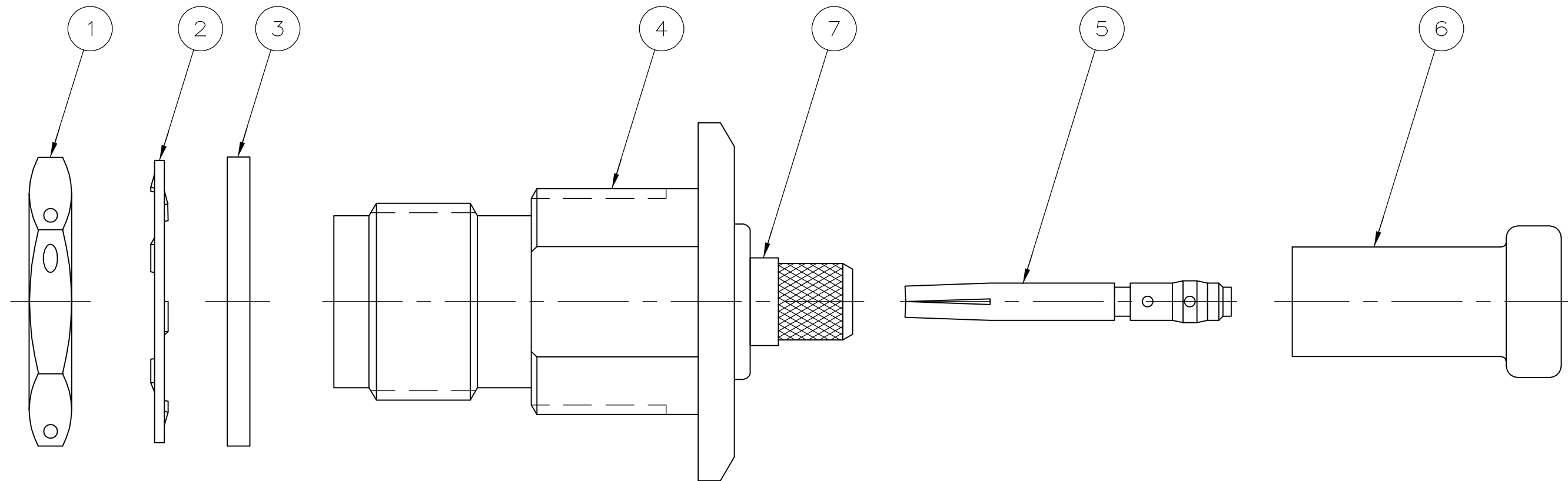

RECOMMENDED PANEL CUTOUT

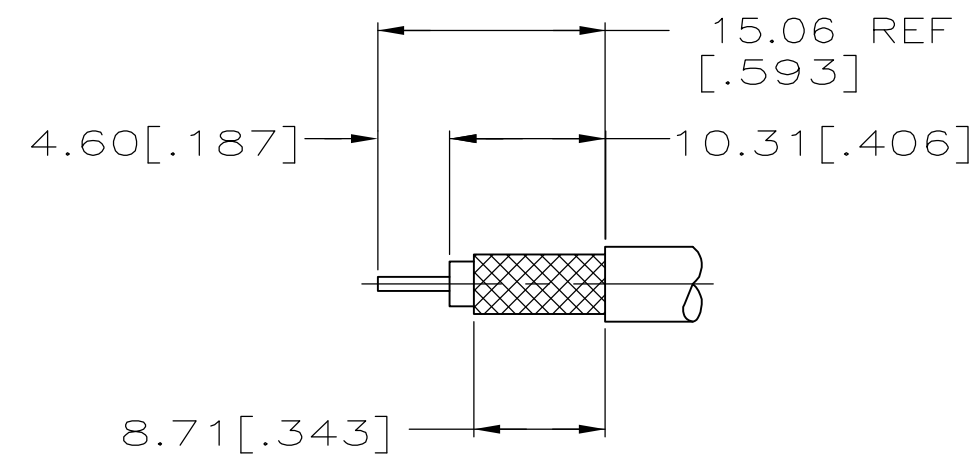

RECOMMENDED STRIP LENGTH

220045-2	RG-142/U & 142B/U	225592-1	9-225560-0	225471-6	225475-2	329633	1-329632-2	1-329631-2	5225557-6
220045-2	RG-58A/U & RG-58C/U	225592-1	9-225560-1	225471-4	225475-2	329633	1-329632-2	1-329631-2	5225557-2
CRIMP WITH TOOL	CABLE SIZE	⑦ SEAL QTY=1	⑥ FERRULE QTY=1	⑤ CONTACT QTY=1	④ JACK ASSY QTY=1	③ GASKET QTY=1	② LOCKWASHER QTY=1	① JAM NUT QTY=1	PART NUMBER

THIS DRAWING IS A CONTROLLED DOCUMENT.

DIMENSIONS: MM [INCHES]	TOLERANCES UNLESS OTHERWISE SPECIFIED:	DWN A. FERNANDEZ-DOCK5 31JAN2005	Tyco Electronics Corporation Harrisburg, PA 17105-3608
	0 PLC ± - 1 PLC ± - 2 PLC ± - 3 PLC ± - 4 PLC ± - ANGLES ± - FINISH -	CHK J. HAVENER 31JAN2005 APVD J. LIPPERT 31JAN2005 PRODUCT SPEC APPLICATION SPEC WEIGHT -	
MATERIAL	FINISH	NAME JACK, BULKHEAD, SERIES TNC SIZE CAGE CODE DRAWING NO RESTRICTED TO A2 00779 C=5225557 -	
CUSTOMER DRAWING		SCALE 4:1	SHEET 1 OF 1 REV 01