



A New Direction in Mixed-Signal

July 2014

Rev. 1A

XR75100 40V Synchronous Step Down COT Controller

GENERAL DESCRIPTION

The XR75100 is a synchronous step-down controller for point-of load supplies up to 20A. A wide 5.5V to 40V input voltage range allows for single supply operation from industry standard 12V, 18V, and 24V DC and AC rails.

With a proprietary emulated current mode Constant On-Time (COT) control scheme, the XR75100 provides extremely fast line and load transient response using ceramic output capacitors. It requires no loop compensation hence simplifying circuit implementation and reducing overall component count. The control loop also provides exceptional load and line regulation and maintains constant operating frequency. A selectable power saving mode allows the user to operate in discontinuous mode (DCM) at light current loads thereby significantly increasing the converter efficiency.

A host of protection features, including over-current, over-temperature, short-circuit and UVLO, help achieve safe operation under abnormal operating conditions.

The XR75100 is available in RoHS compliant, green/halogen free space-saving 16-pin 3x3 QFN package.

EVALUATION BOARD MANUAL



FEATURES

- **20A Capable Step Down Controller**
 - Wide 5.5V to 40V Input Voltage Range
 - Integrated high Current 2A/3A Drivers
 - 0.6V to 30V Adjustable Output Voltage
- **Proprietary Constant On-Time Control**
 - No Loop Compensation Required
 - Ceramic Output Cap. Stable operation
 - Programmable 200ns-2µs On-Time
 - Constant 100kHz-800kHz Frequency
 - Selectable CCM or CCM/DCM Operation

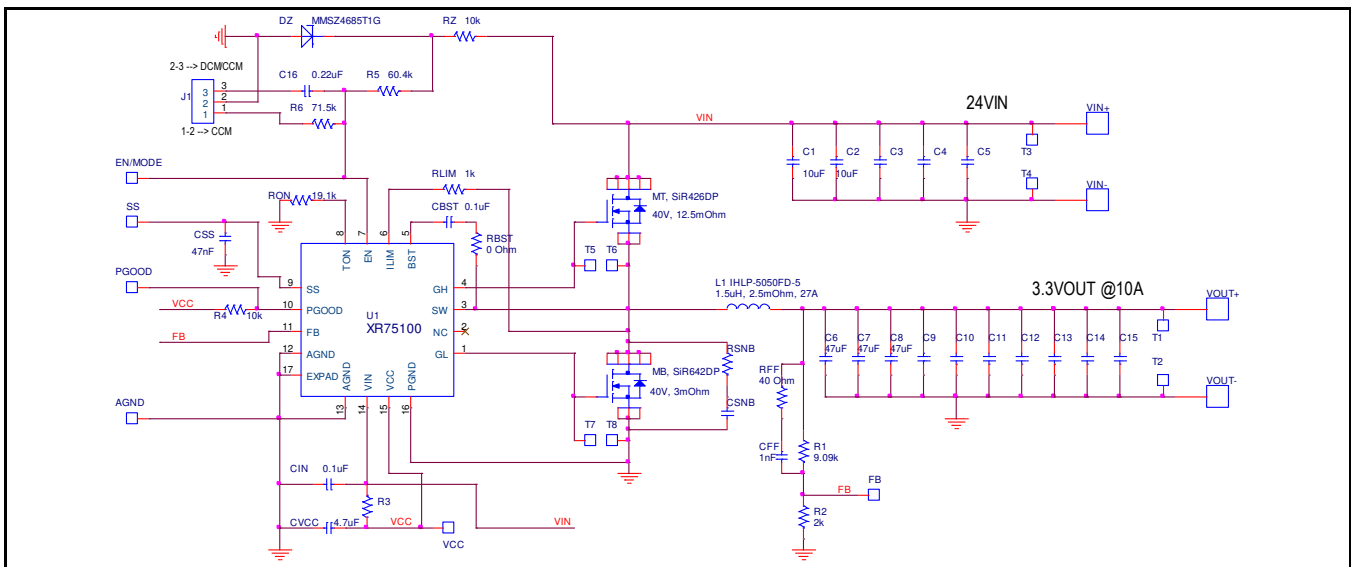

Fig. 1: XR75100 Evaluation Board Schematics

PIN ASSIGNMENT

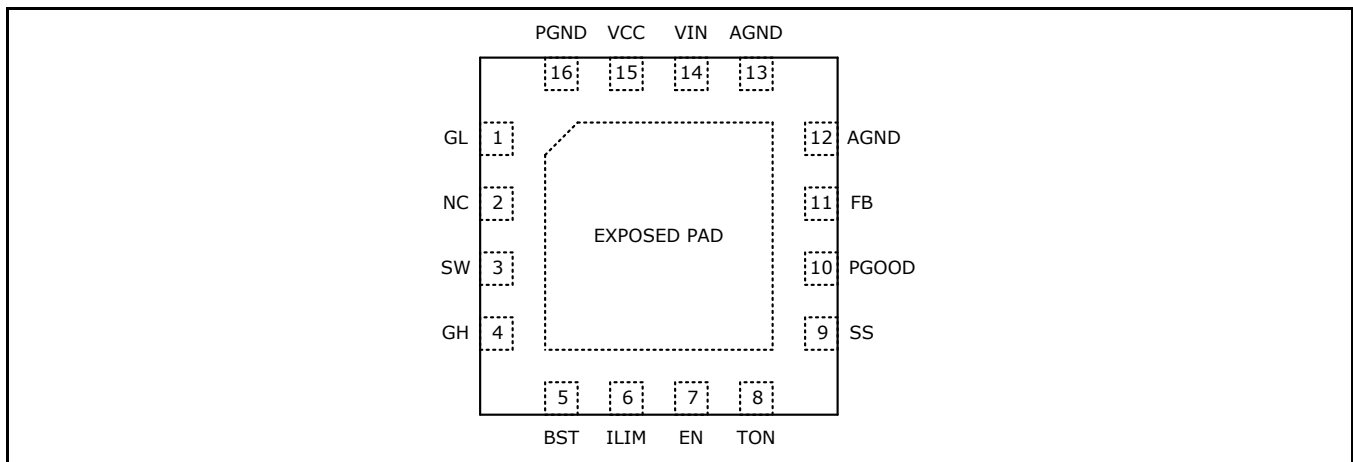

Fig. 2: XR75100 Pin Assignment

PIN DESCRIPTION

Name	Pin Number	Description
GL	1	Driver output for Low-side N-channel synchronous MOSFET.
NC	2	Internally not connected. Leave this pin floating.
SW	3	Lower supply rail for high-side gate driver GH. Connect this pin to the junction between the two external N-channel MOSFETs.
GH	4	Driver output for high-side N-channel switching MOSFET.
BST	5	High-side driver supply pin. Connect a 0.1uF bootstrap capacitor between BST and SW.
ILIM	6	Over-current protection programming. Connect with a resistor to the Drain of the low-side MOSFET.
EN/MODE	7	Precision enable pin. Pulling this pin above 1.9V will turn the IC on and it will operate in Forced CCM. If the voltage is raised above 3.0V then the IC will operate in DCM or CCM depending on load.
TON	8	Constant on-time programming pin. Connect with a resistor to AGND.
SS	9	Soft-Start pin. Connect an external capacitor between SS and AGND to program the soft-start rate based on the 10uA internal source current.
PGOOD	10	Power-good output. This open-drain output is pulled low when V_{OUT} is outside the regulation.
FB	11	Feedback input to feedback comparator. Connect with a set of resistors to V_{OUT} and GND in order to program V_{OUT} .
AGND	12, 13	Analog ground. Control circuitry of the IC is referenced to this pin.
VIN	14	IC supply input. Provides power to internal LDO.
VCC	15	The output of LDO. For operation using a 5V rail, VCC should be shorted to VIN.
PGND	16	Ground for low side driver
Exposed Pad		Thermal pad for heat dissipation. Connect to AGND with a short trace.

ORDERING INFORMATION

Refer to XR75100's datasheet and/or www.exar.com for exact and up to date ordering information.



A New Direction in Mixed-Signal

40V Synchronous Step Down COT Controller

USING THE EVALUATION BOARD

POWERING UP

Connect the VIN+/VIN- with short/thick leads to power supply. Use test pins T3 and T4 to monitor VIN+ and VIN- respectively. Connect VOUT+/VOUT- with short/thick leads to electronic load. Use test pins T1 and T2 to monitor VOUT+ and VOUT- respectively. Apply 24V using the power supply. The XR75100EVB should power up and regulate the output at 3.3V. The Evaluation Board is rated at 10A. Overcurrent protection will trigger at about 16A.

JUMPER J1

If the jumper is set to CCM position, the converter will operate in 'Forced CCM'.

If the jumper is set to DCM/CCM position, the converter will operate at DCM or CCM, depending on load. Transition from DCM to CCM is at approximately 3A.

INPUT VOLTAGE RANGE

MOSFETs used in this evaluation board have a 40V rating. Therefore switching voltage transients limit the maximum VIN to 30V. In order to operate at VIN up to 40V, higher voltage MOSFETs have to be used. For example 60V rated SiR664DP and SiR662DP can be used for MT and MB respectively.



A New Direction in Mixed-Signal

XR75100

40V Synchronous Step Down COT Controller

EVALUATION BOARD SCHEMATICS

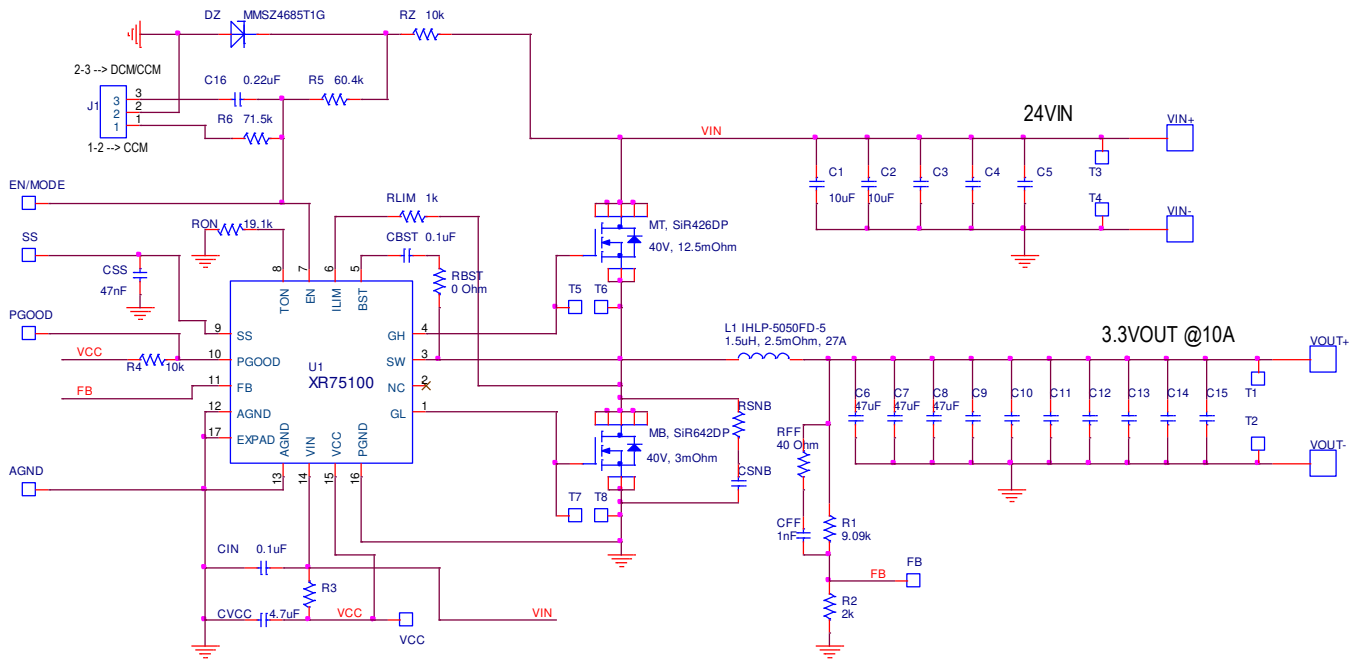

BILL OF MATERIAL

Reference Designator	Qty.	Manufacturer	Manufacturer Part Number	Size	Component
PCB	1	Exar	X75100EVB		XR75100 Evaluation kit
U1	1	Exar	XR75100EL-F	QFN-16	Constant On-Time Buck controller
MT	1	VISHAY-DALE	SIR426DP	Power SO-8	N-Ch. 40V, 30A, 12.5mOhm MOSFET
MB	1	VISHAY-DALE	SIR642DP	Power SO-8	N-Ch. 40V, 60A, 3.0mOhm, MOSFET
DZ	1	ON SEMI	MMSZ4685T1G	SOD-123	Diode Zener 3.6V, 500MW,
L1	1	VISHAY-DALE	IHLP5050FDER1R5M01	13.2x12.9mm	Shielded inductor, 1.5uH, 2.5mΩ, 27A
C1,C2	2	MURATA	GRM32ER71H106KA12L	1210	CERAMIC CAP., 10uF, 50V, X7R, 10%
C6,C7,C8	3	MURATA	GRM32ER71A476KE15L	1210	CERAMIC CAP., 47uF, 10V, X7R, 10%
CBST	1	MURATA	GRM188R71C105KA12D	0603	CERAMIC CAP., 1uF, 16V, X7R, 10%
CFF	1	MURATA	GRM188R71H102KA01D	0603	CERAMIC CAP., 1000pF, 50V, X7R, 10%
CIN,C16	2	MURATA	GRM188R71H104KA93D	0603	CERAMIC CAP., 0.1uF, 50V, X7R, 10%
CVCC	1	MURATA	GRM21BR71C475KA73L	0805	CERAMIC CAP., 4.7uF, 16V, X7R, 10%
CSS	1	MURATA	GRM188R71H473KA61D	0603	CERAMIC CER, 47nF, 50V, X7R, 10%
Csnub	0	DONT POPULATE
R1	1	PANASONIC	ERJ-3EKF9091V	0603	Resistor 9.09k, 1/10W, 1%, SMD
R2	1	PANASONIC	ERJ-3EKF2001V	0603	Resistor 2K Ohm, 1/10W, 1%, SMD
R4,RZ	2	PANASONIC	ERJ-3EKF1002V	0603	Resistor 10.0K Ohm, 1/10W, 1%, SMD
RFF	1	PANASONIC	ERJ-3EKF40R2V	0603	Resistor 40.2 Ohm, 1/10W, 1%, SMD
RBST	1	PANASONIC	ERJ-3GEY0R00V	0603	Resistor 0Ω, Jumper SMD
R5	1	PANASONIC	ERJ-3EKF1333V	0603	Resistor 133K Ohm, 1/10W, 1%, SMD
R3	0	DONT POPULATE	---	---	---
R6	1	PANASONIC	ERJ-3EKF1333V	0603	Resistor 158K Ohm, 1/10W, 1%, SMD
RLIM	1	PANASONIC	ERJ-3EKF1001V	0603	Resistor 1.0K Ohm, 1/10W, 1%, SMD
RON	1	PANASONIC	ERJ-3EKF1912V	0603	Resistor 19.1K Ohm, 1/10W, 1%, SMD
Rsnub	0	DONT POPULATE			
J1	1	Würth Elektronik	61300311121		3-PIN CONNECTOR
VIN+, VIN-, VOUT+, VOUT-	4	Würth Elektronik	7471287	0.32X0.10in	Mounting Tab
T7/T8	1	Würth Elektronik	61300211121		DUAL TEST POINT
T1, T2, T3,T4, EN/MODE,SS,PGOOD, AGND, VCC	9	Würth Elektronik	61300111121		SINGLE Test Point Post

EVALUATION BOARD LAYOUT

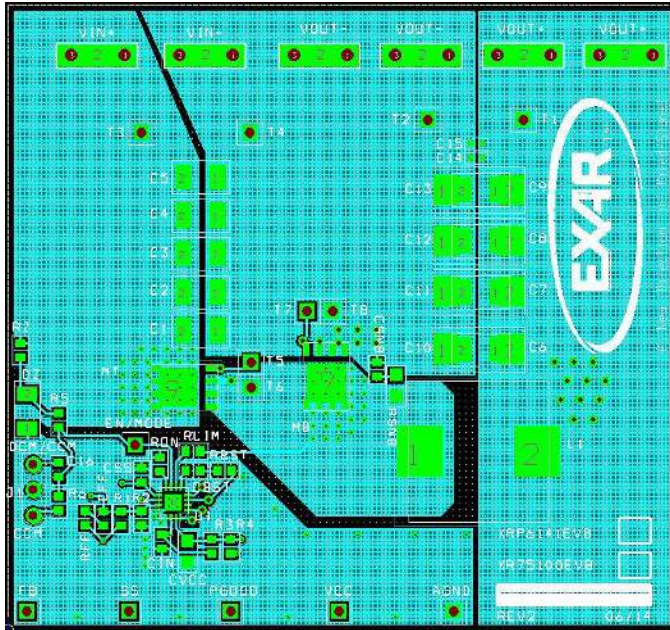

Fig. 3: Component Placement – Top Side

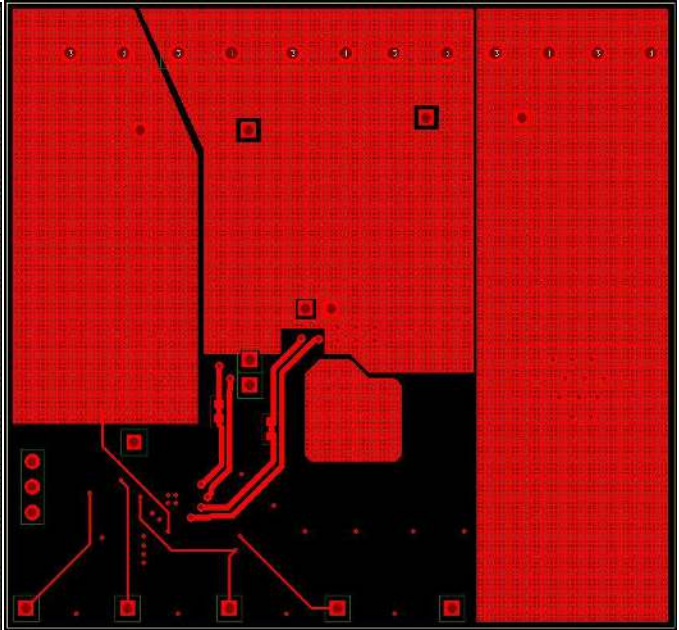

Fig. 4: Bottom Side

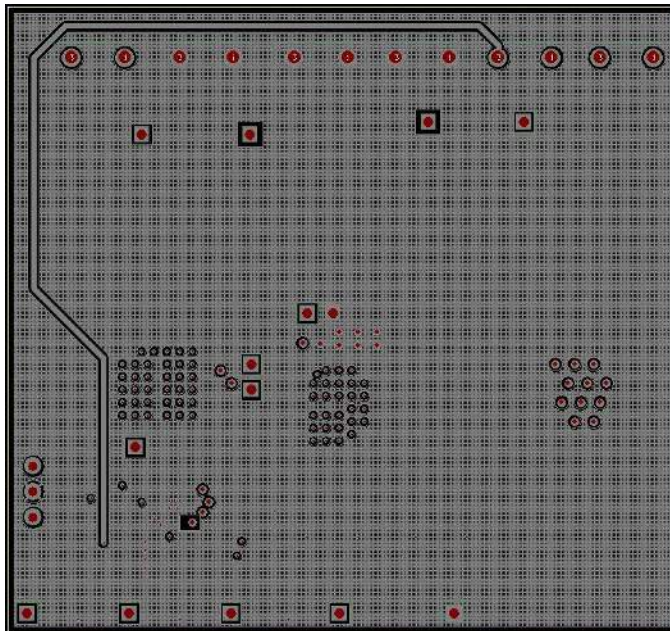

Fig. 5: Layer 2



Fig. 6: Layer 3

DOCUMENT REVISION HISTORY

Revision	Date	Description
1.0.0	7/15/14	Initial release of document

BOARD REVISION HISTORY

Board Revision	Date	Description
146-6702-05	7/15/14	Initial release of evaluation board

FOR FURTHER ASSISTANCE

Email:

customersupport@exar.com

powertechsupport@exar.com

Exar Technical Documentation:

<http://www.exar.com/TechDoc/default.aspx>



EXAR CORPORATION

HEADQUARTERS AND SALES OFFICES

48720 Kato Road

Fremont, CA 94538 – USA

Tel.: +1 (510) 668-7000

Fax: +1 (510) 668-7030

www.exar.com

NOTICE

EXAR Corporation reserves the right to make changes to the products contained in this publication in order to improve design, performance or reliability. EXAR Corporation assumes no responsibility for the use of any circuits described herein, conveys no license under any patent or other right, and makes no representation that the circuits are free of patent infringement. Charts and schedules contained here in are only for illustration purposes and may vary depending upon a user's specific application. While the information in this publication has been carefully checked; no responsibility, however, is assumed for inaccuracies.

EXAR Corporation does not recommend the use of any of its products in life support applications where the failure or malfunction of the product can reasonably be expected to cause failure of the life support system or to significantly affect its safety or effectiveness. Products are not authorized for use in such applications unless EXAR Corporation receives, in writing, assurances to its satisfaction that: (a) the risk of injury or damage has been minimized; (b) the user assumes all such risks; (c) potential liability of EXAR Corporation is adequately protected under the circumstances.

Reproduction, in part or whole, without the prior written consent of EXAR Corporation is prohibited.