

**SINGLE-PHASE GLASS PASSIVATED
MINI FAST RECOVERY SURFACE MOUNT BRIDGE RECTIFIER**
VOLTAGE RANGE 50 to 1000 Volts CURRENT 0.8 Ampere

FEATURES

- * Surge overload rating - 30 amperes peak
- * Ideal for printed circuit board
- * Reliable low cost construction utilizing molded
- * Glass passivated device
- * Polarity symbols molded on body
- * Mounting position: Any
- * Weight: 0.5 gram

MECHANICAL DATA

- * Epoxy : Device has UL flammability classification 94V-0

MAXIMUM RATINGS AND ELECTRICAL CHARACTERISTICS

Ratings at 25 °C ambient temperature unless otherwise specified.
Single phase, half wave, 60 Hz, resistive or inductive load.
For capacitive load, derate current by 20%.

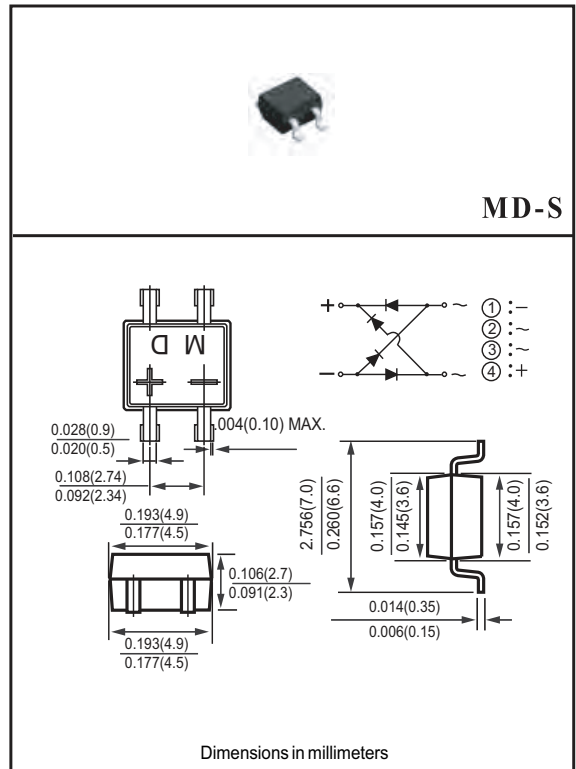

MAXIMUM RATINGS (At TA = 25°C unless otherwise noted)

RATINGS	SYMBOL	FMD1S	FMD2S	FMD3S	FMD4S	FMD5S	FMD6S	FMD7S	UNITS
Maximum Recurrent Peak Reverse Voltage	VRRM	50	100	200	400	600	800	1000	Volts
Maximum RMS Bridge Input Voltage	VRMS	35	70	140	280	420	560	700	Volts
Maximum DC Blocking Voltage	VDC	50	100	200	400	600	800	1000	Volts
Maximum Average Forward Output Rectified Current TA = 30°C -on glass-epoxy P.C.B. (NOTE 1) -on aluminum substrate (NOTE 2)	IO					0.5			Amp
Peak Forward Surge Current 8.3 ms single half sine-wave superimposed on rated load (JEDEC method)	IFSM					30			Amps
Typical Current Squared Time	i ² T					3.74			A ² S
Typical Junction Capacitance (Note3)	CJ					15			pF
Operating and Storage Temperature Range	TJ,TSTG					-55 to + 150			°C

ELECTRICAL CHARACTERISTICS (At TA = 25°C unless otherwise noted)

CHARACTERISTICS	SYMBOL	FMD1S	FMD2S	FMD3S	FMD4S	FMD5S	FMD6S	FMD7S	UNITS
Maximum Forward Voltage Drop per Bridge Element at 0.4A DC	VF					1.30			Volts
Maximum Reverse Current at rated DC Blocking Voltage per element	IR					10			uAmps
						100			uAmps
Maximum Reverse Recovery Time (Note 4)	trr	150				250	500		nSec

NOTE: 1. On glass-epoxy P.C.B. mounted on 0.05 X 0.05" (1.3 X 1.3mm) pads.

2. On aluminum substrate P.C.B. with an area of 0.8 X 0.8 X 0.25" (20 X 20 X 6.4mm) mounted on 0.05 X 0.05" (1.27 X 1.27mm) solder pad.

3. Measured at 1MHz and applied reverse voltage of 4.0 volts.

4. Test Conditions: IF = 0.5A, IR = -1.0A, IRR = -0.25A.

5. Suffix "-S" Surface Mount for Mini Dip Bridge.

RATING AND CHARACTERISTIC CURVES (FMD1S THRU FMD7S)

FIG. 1 - TEST CIRCUIT DIAGRAM AND REVERSE RECOVERY TIME CHARACTERISTIC

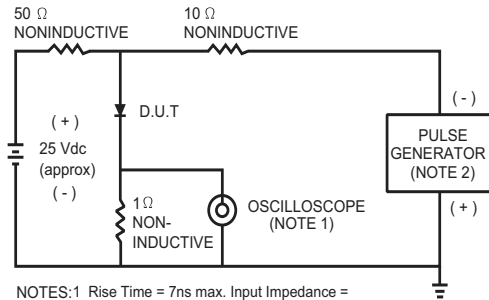

NOTES: 1. Rise Time = 7ns max. Input Impedance = 1 megohm, 22pF.
2. Rise Time = 10ns max. Source Impedance = 50 ohms.

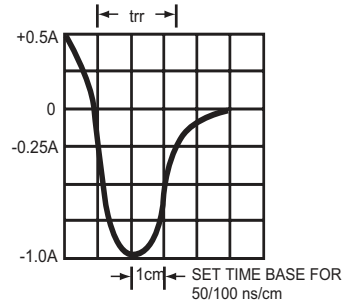

FIG. 1 - TYPICAL FORWARD CURRENT DERATING CURVE

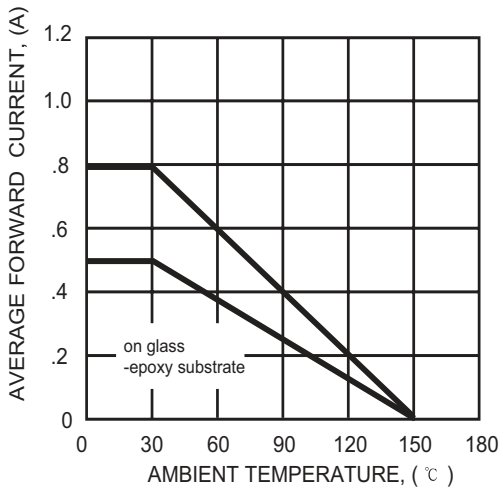

FIG. 3 - TYPICAL INSTANTANEOUS FORWARD CHARACTERISTICS

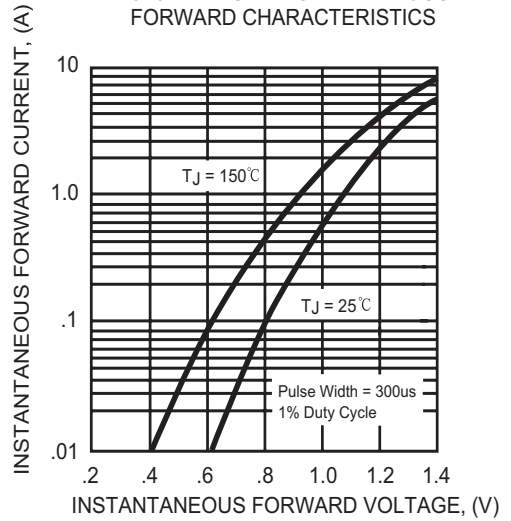

FIG. 4 - TYPICAL JUNCTION CAPACITANCE

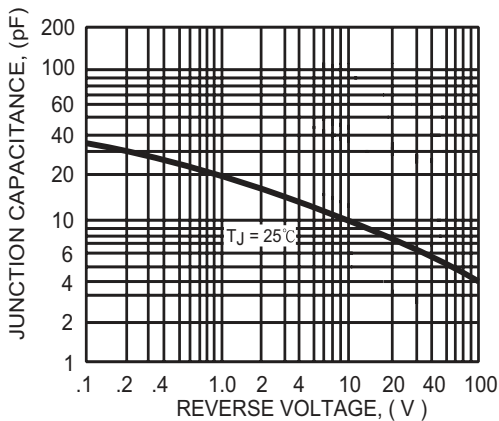
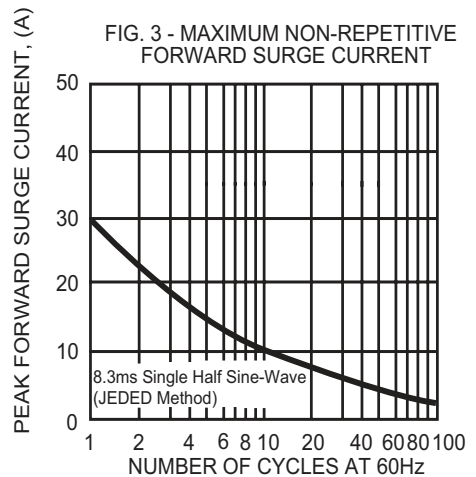
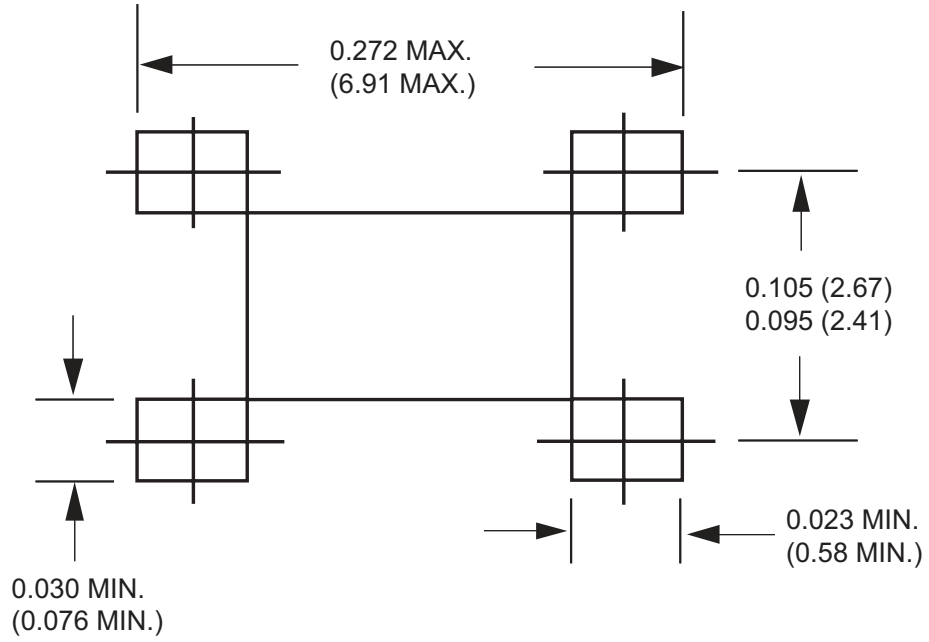

FIG. 3 - MAXIMUM NON-REPETITIVE FORWARD SURGE CURRENT



Mounting Pad Layout



Dimensions in inches and (millimeters)

PACKAGING OF DIODE AND BRIDGE RECTIFIERS

REEL PACK

PACKAGE	packing code	EA PER REEL	COMPONENT SPACE(mm)	TAPE SPACE (mm)	REEL DIA (mm)	CARTON SIZE (mm)	EA PER CARTON	GROSS WEIGHT(Kg)
R-1	-T	5,000	5.0	52	330	355*360*350	20,000	7.25
A-405	-T	5,000	5.0	330	52	355*360*350	20,000	8.13
DO-41	-T	5,000	5.0	52	330	355*360*350	20,000	10.49
DO-15	-T	4,000	5.0	52	330	355*360*350	16,000	10.05
R-3	-T	3,000	5.0	52	330	355*360*350	12,000	10.37
DO-201AD	-T	1,200	9.5	52	330	355*360*350	4,800	8.93
1.5KE	-T	1,200	10.0	52.4	330	355*360*350	4,800	8.05
R-6	-T	500	9.5	52	330	355*360*350	2,000	7.29
SMA	-T	1,500	---	---	178	465*220*260	48,000	8.40
SMA	-W	5,000	---	---	330	355*360*350	80,000	14.20
MELF	-T	1,500	---	---	178	465*220*260	48,000	11.14
MELF	-W	5,000	---	---	330	355*360*350	80,000	19.60
DB-S	-T	1,000	---	---	330	355*360*350	8,000	9.85
MD	-T	500	---	---	178	465*220*260	16,000	---
MD	-W	3,000	---	---	330	355*360*350	48,000	15.50
SMB	-T	500	---	---	178	465*220*260	16,000	---
SMB	-W	3,000	---	---	330	355*360*350	48,000	13.90
SMC	-T	500	---	---	176	465*220*260	12,000	---
SMC	-W	3,000	---	---	330	355*360*350	24,000	11.50
D2PAK	-W	800	---	---	330	355*360*350	6,400	---

AMMO PACK

PACKAGE	PACKING CODE	REEL (EA)	COMPONENT SPACE(mm)	TAPE SPACE (mm)	BOX SIZE (mm)	CARTON SIZE(mm)	CARTON (EA)	GROSS WEIGHT (Kg)
R-1	-F	3,000	5.0	52	255*73*100	402*270*225	30,000	8.5
A-405	-F	3,000	5.0	52	255*73*100	402*270*225	30,000	9.6
DO-41	-F	3,000	5.0	52	255*73*100	402*270*225	30,000	13.0
DO-15	-F	1,500	5.0	52	255*73*100	402*270*225	15,000	8.8
R-3	-F	1,500	5.0	52	255*73*100	402*270*225	15,000	11.2
DO-201AD	-F	600	9.5	52	255*73*100	402*270*225	6,000	9.9
R-6	-F	300	9.5	52	255*73*100	402*270*225	3,000	8.7
R-1	-E	3,000	5.0	26	256*46*94	347*320*220	42,000	8.35
A-405	-E	3,000	5.0	26	256*46*94	347*320*220	42,000	9.61
DO-41	-E	3,000	5.0	26	256*46*94	347*320*220	42,000	12.41
R-1	-J	3,000	12.7	---	328*170*42	355*360*350	42,000	13.93
R-1	-I	2,000	12.7	---	328*170*42	355*360*350	28,000	9.31
A405	-N	2,000	12.7	---	328*170*42	355*360*350	28,000	11.41



RECTRON

Attachment information about FMDXS

1. Internal Circuit

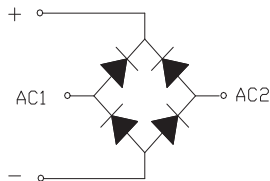

2. Marking on the body

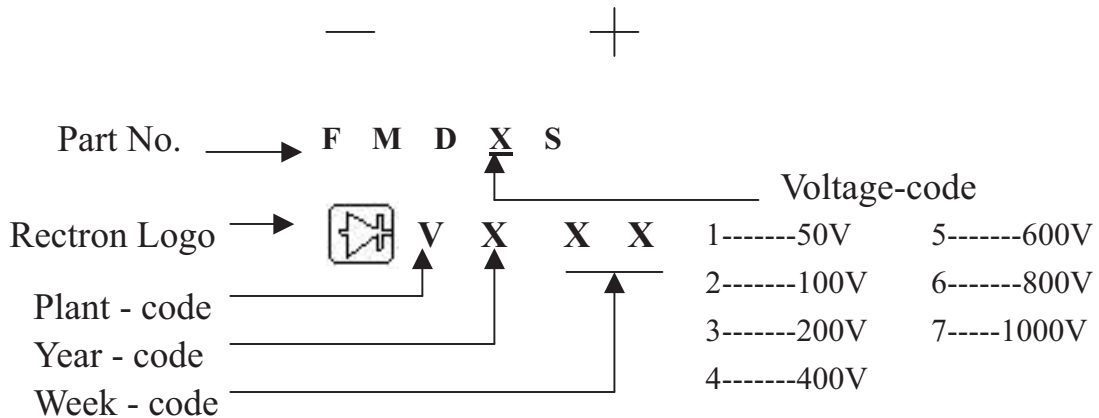

3. Items marked on the inner box and carton

3.1 On the box (for -B)

CUSTOMER
TYPE
LOT NO.
QUANTITY
Q.A.
DATE

3.2 On the carton

CUSTOMER
TYPE
QUANTITY
LOT NO.
REMARK

DISCLAIMER NOTICE

Rectron Inc reserves the right to make changes without notice to any product specification herein, to make corrections, modifications, enhancements or other changes. Rectron Inc or anyone on its behalf assumes no responsibility or liability for any errors or inaccuracies. Data sheet specifications and its information contained are intended to provide a product description only. "Typical" parameters which may be included on RECTRON data sheets and/ or specifications can and do vary in different applications and actual performance may vary over time. Rectron Inc does not assume any liability arising out of the application or use of any product or circuit.

Rectron products are not designed, intended or authorized for use in medical, life-saving implant or other applications intended for life-sustaining or other related applications where a failure or malfunction of component or circuitry may directly or indirectly cause injury or threaten a life without expressed written approval of Rectron Inc. Customers using or selling Rectron components for use in such applications do so at their own risk and shall agree to fully indemnify Rectron Inc and its subsidiaries harmless against all claims, damages and expenditures.