

## Ultralow capacitance ESD protection

Datasheet – production data

### Features

- 4-line ESD protection (IEC 61000-4-2)
- Protects  $V_{BUS}$  when applicable
- Ultralow capacitance: 0.6 pF at 825 MHz
- Fast response time compared with varistors
- SOT23-6L package
- RoHS compliant

### Benefits

- ESD standards compliance guaranteed at device level, hence greater immunity at system level
- ESD protection of  $V_{BUS}$ , when applicable, allows ESD current flowing to ground when ESD event occurs on data line
- Optimized rise and fall times for maximum data integrity
- Consistent D+ / D- signal balance:
  - Optimum capacitance matching tolerance for ultralow intra-pair skew:  
I/O to ground = 0.015 pF,  
I/O to I/O = 0.007 pF
  - Matching high bit rate DVI, HDMI, and IEEE 1394 requirements
- Low PCB space occupation: 9 mm<sup>2</sup>
- Low leakage current for longer operation of battery powered devices
- Higher reliability offered by monolithic integration

### Complies with these standards

- IEC 61000-4-2 level 4:
  - ±15 kV (air discharge)
  - ±8 kV (contact discharge)
- MIL STD883G-Method 3015-7

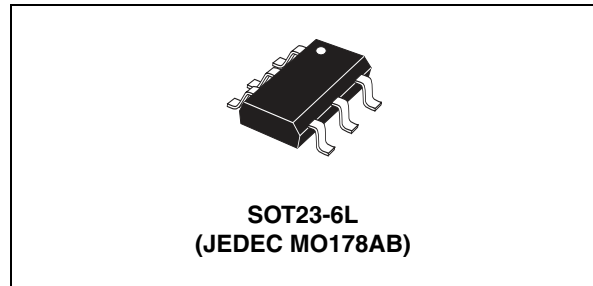

### Applications

- DVI ports up to 1.65 Gb/s
- HDMI ports up to 1.65 Gb/s
- IEEE 1394a, and b up to 1.6 Gb/s
- USB 2.0 ports up to 480 Mb/s (high speed), backwards compatible with USB 1.1 low and full speed
- Ethernet port: 10/100/1000 Mb/s
- SIM card protection
- Video line protection

### Description

The DVIULC6-4SC6 is a monolithic, application specific discrete device dedicated to ESD protection of high speed interfaces, such as DVI, HDMI, IEEE 1394a, and b, USB 2.0, Ethernet links and video lines.

Its ultralow line capacitance secures a high level of signal integrity without compromise in protecting sensitive chips against the most stringently characterized ESD strikes.

# 1 Characteristics

Figure 1. Functional diagram

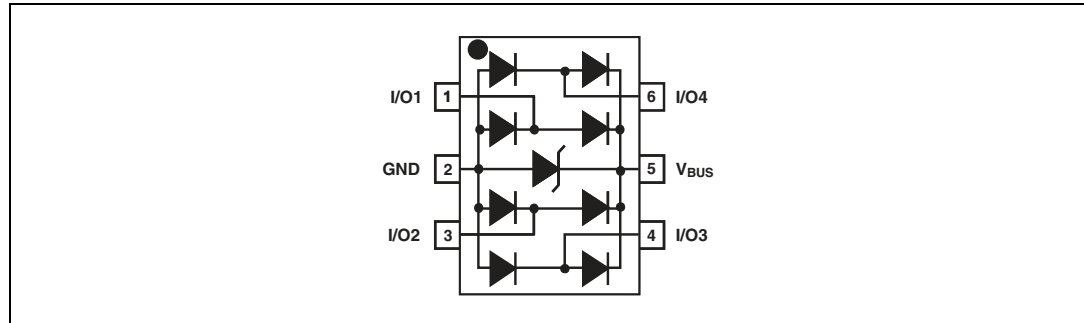

Table 1. Absolute ratings

Symbol	Parameter		Value	Unit
V <sub>PP</sub>	Peak pulse voltage	IEC 61000-4-2 air discharge IEC 61000-4-2 contact discharge MIL STD883G-Method 3015-7	±15 ±15 ±25	kV
P <sub>pp</sub>	Peak pulse power		80	W
T <sub>stg</sub>	Storage temperature range		-55 to +150	°C
T <sub>j</sub>	Operating junction temperature range		-40 to +125	°C
T <sub>L</sub>	Lead solder temperature (10 seconds duration)		260	°C

Table 2. Electrical characteristics (T<sub>amb</sub> = 25 °C)

Symbol	Parameter	Test conditions	Value			Unit
			Min.	Typ.	Max.	
I <sub>RM</sub>	Leakage current	V <sub>RM</sub> = 5 V	-	-	0.5	µA
V <sub>BR</sub>	Breakdown voltage between V <sub>BUS</sub> and GND	I <sub>R</sub> = 1 mA	6	-	-	V
V <sub>CL</sub>	Clamping voltage	I <sub>PP</sub> = 1 A, t <sub>p</sub> = 8/20 µs Any I/O pin to GND	-	-	12	V
		I <sub>PP</sub> = 5 A, t <sub>p</sub> = 8/20 µs Any I/O pin to GND	-	-	17	V
C <sub>i/o-GND</sub>	Capacitance between I/O and GND	V <sub>R</sub> = 0 V, F = 1 MHz	-	0.85	1	pF
		V <sub>R</sub> = 0 V, F = 825 MHz	-	0.6	-	
ΔC <sub>i/o-GND</sub>	Capacitance variation between I/O and GND	-	-	0.015	-	
C <sub>i/o-i/o</sub>	Capacitance between I/O	V <sub>R</sub> = 0 V, F = 1 MHz	-	0.42	0.5	pF
		V <sub>R</sub> = 0 V, F = 825 MHz	-	0.3	-	
ΔC <sub>i/o-i/o</sub>	Capacitance variation between I/O	-	-	0.007	-	

Figure 2. Line capacitance versus line voltage (typical values)

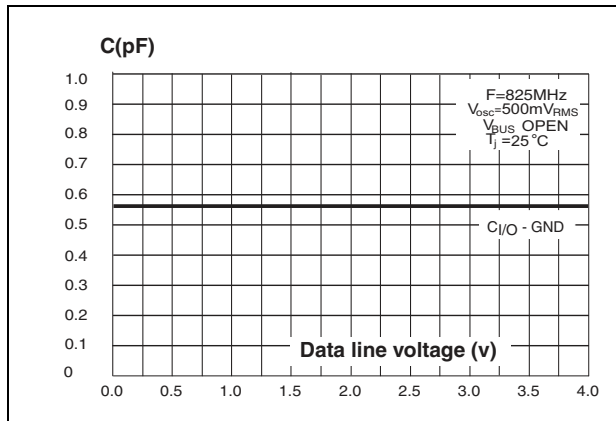

Figure 3. Line capacitance versus frequency (typical values)

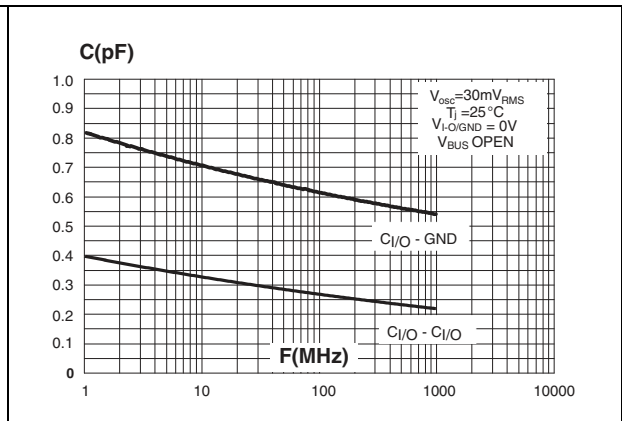

Figure 4. Relative variation of leakage current versus junction temperature (typical values)

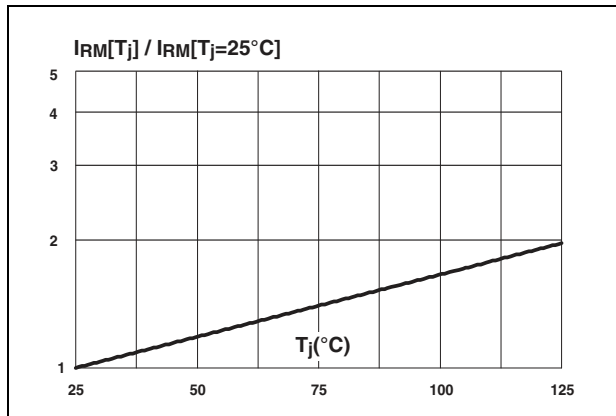

Figure 5. Frequency response

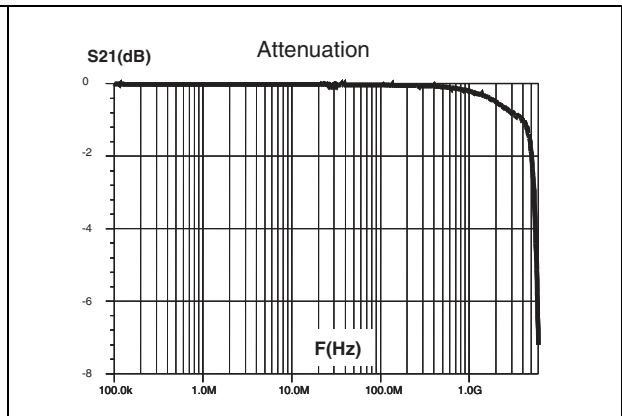

Figure 6. Remaining voltage after the DVIULC6-4SC6 during positive ESD surge<sup>(1)</sup>

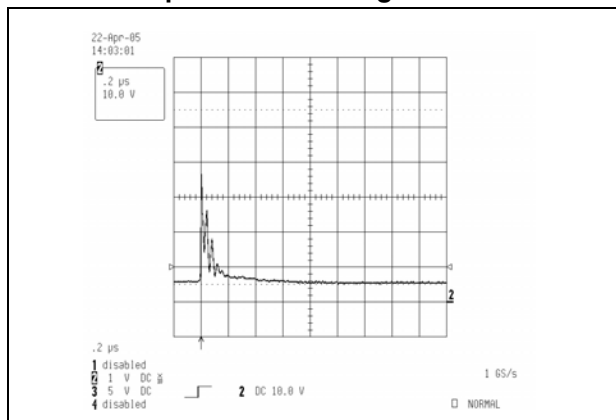
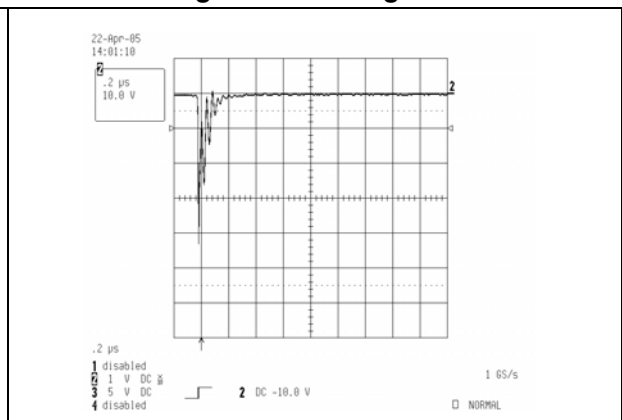
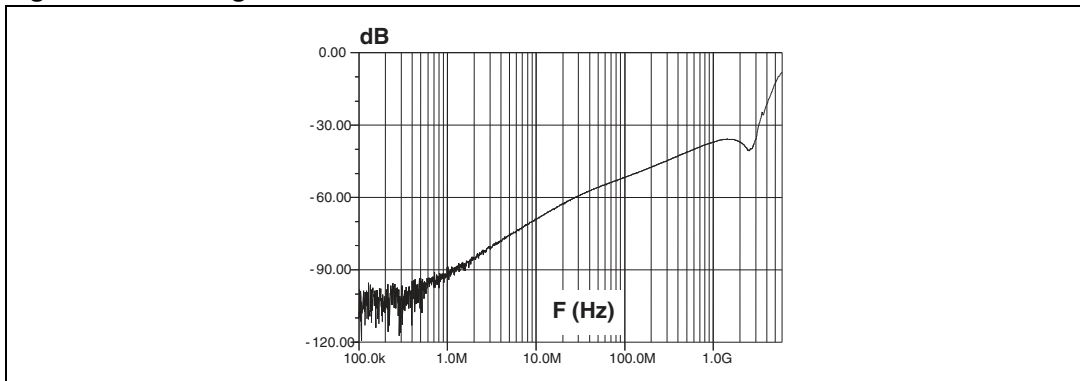

Figure 7. Remaining voltage after the DVIULC6-4SC6 during negative ESD surge<sup>(1)</sup>



1. measurements were done with DVIULC-4SC6 in open circuit

Figure 8. Analog crosstalk results



## 2 Application examples

Figure 9. DVI/HDMI digital single link application

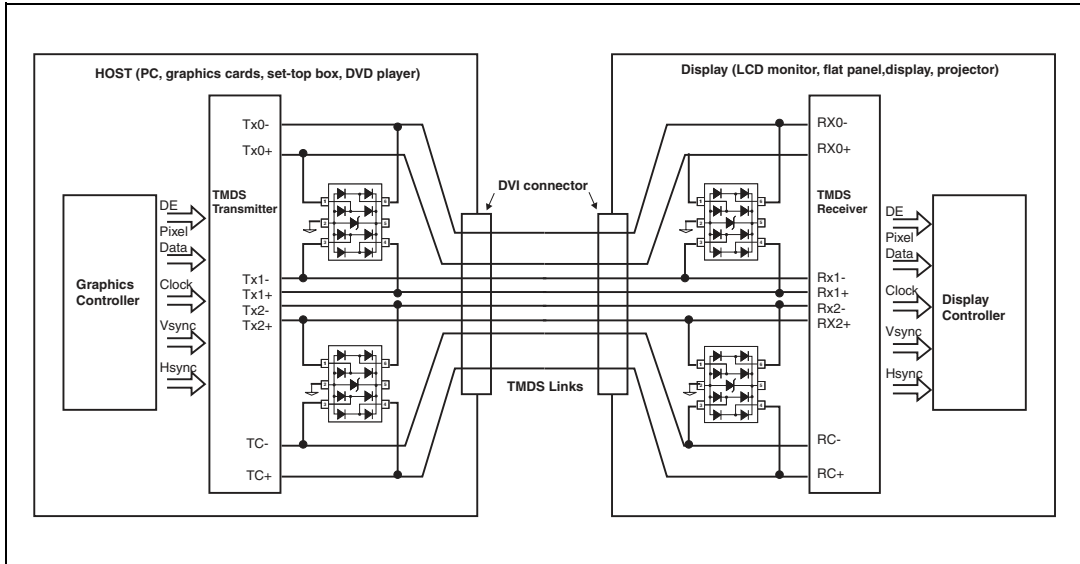
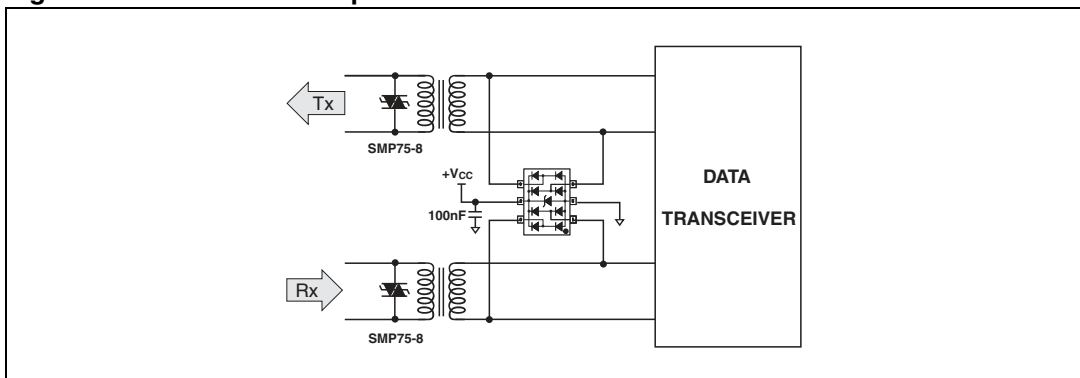

Figure 10. T1/E1/Ethernet protection



## 3 Technical information

### 3.1 Surge protection

The DVIULC6-4SC6 is particularly optimized to perform ESD surge protection based on the rail to rail topology.

The clamping voltage  $V_{CL}$  can be calculated as follows:

$$V_{CL+} = V_{BUS} + V_F \text{ for positive surges}$$

$$V_{CL-} = -V_F \text{ for negative surges}$$

with:  $V_F = V_T + R_d \cdot I_p$

$V_F$  = forward drop voltage,  $V_T$  = forward drop threshold voltage)

#### Calculation example

We can assume that the value of the dynamic resistance of the clamping diode is typically:

$$R_d = 1.4 \Omega \text{ and } V_T = 1.2 \text{ V.}$$

For an IEC 61000-4-2 surge Level 4 (Contact Discharge:  $V_g = 8 \text{ kV}$ ,  $R_g = 330 \Omega$ ),  $V_{BUS} = +5 \text{ V}$ , and, in a first approximation, we assume that:  $I_p = V_g / R_g = 24 \text{ A}$ .

We find:

$$V_{CL+} = +39 \text{ V}$$

$$V_{CL-} = -34 \text{ V}$$

*Note: The calculations do not take into account phenomena due to parasitic inductances.*

### 3.2 Surge protection application example

If we consider that the connections from the pin  $V_{BUS}$  to  $V_{CC}$  and from GND to PCB GND plane are two tracks 10 mm long and 0.5 mm wide, we can assume that the parasitic inductances,  $L_W$  of these tracks are about 6 nH. So when an IEC 61000-4-2 surge occurs, due to the rise time of this spike ( $t_r = 1 \text{ ns}$ ), the voltage  $V_{CL}$  has an extra value equal to  $L_W \cdot di/dt$ .

The  $di/dt$  is calculated as:  $di/dt = I_p/t_r = 24 \text{ A/ns}$  for an IEC 61000-4-2 surge level 4 (contact discharge  $V_g = 8 \text{ kV}$ ,  $R_g = 330 \Omega$ )

The over voltage due to the parasitic inductances is:  $L_W \cdot di/dt = 6 \times 24 = 144 \text{ V}$

By taking into account the effect of these parasitic inductances due to unsuitable layout, the clamping voltage will be:

$$V_{CL+} = +39 + 144 = 183 \text{ V}$$

$$V_{CL-} = -34 - 144 = -178 \text{ V}$$

We can reduce as much as possible these phenomena with simple layout optimization.

This is the reason why some recommendations have to be followed (see [Section 3.3: How to ensure good ESD protection](#)).

### 3.3 How to ensure good ESD protection

While the DVIULC6-4SC6 provides a high immunity to ESD surge, an efficient protection depends on the layout of the board. In the same way, with the rail to rail topology, the track from  $V_{BUS}$  pin to the power supply  $+V_{CC}$ , and from  $V_{BUS}$  pin to GND pin must be as short as possible to avoid over voltages due to parasitic phenomena (see [Figure 11](#) and [Figure 12](#) for layout considerations).

**Figure 11. IESD behavior: parasitic phenomena due to unsuitable layout**

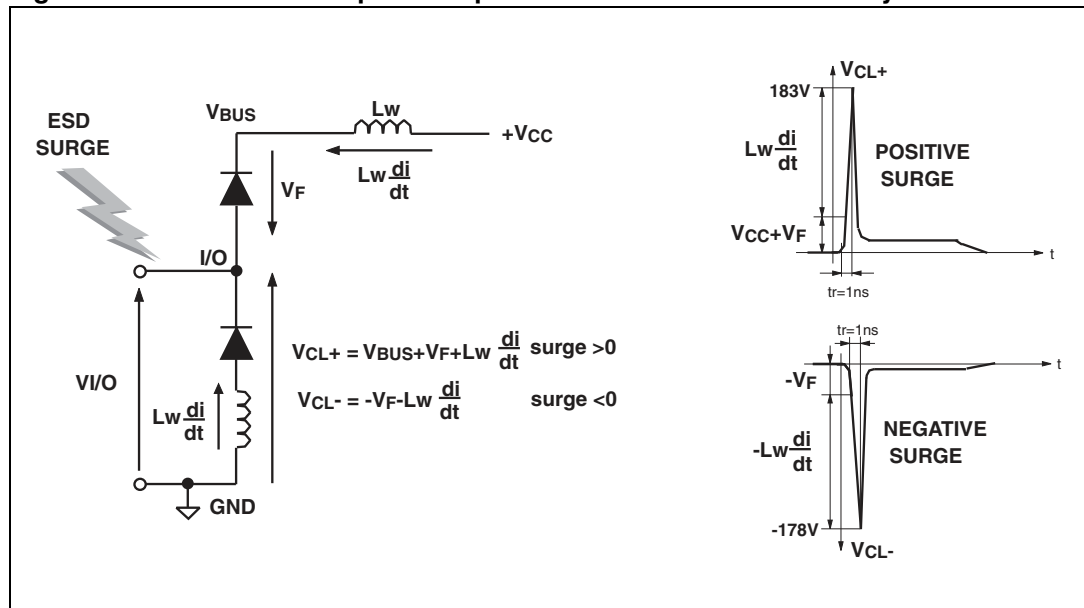

**Figure 12. ESD behavior: layout optimization and addition of a 100 nF capacitor**

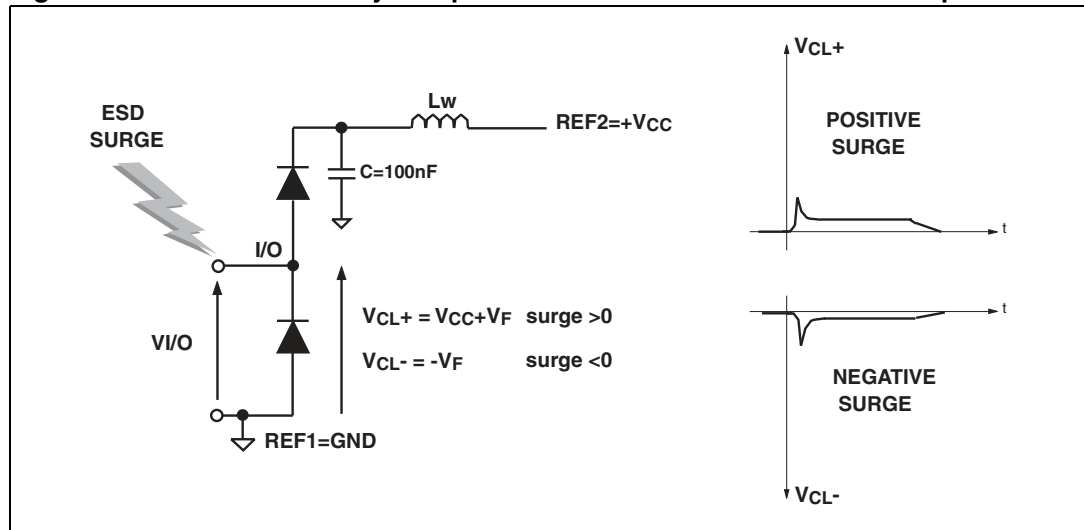

**Figure 13. PCB layout considerations ( $V_{CC}$  connection is application dependent)**

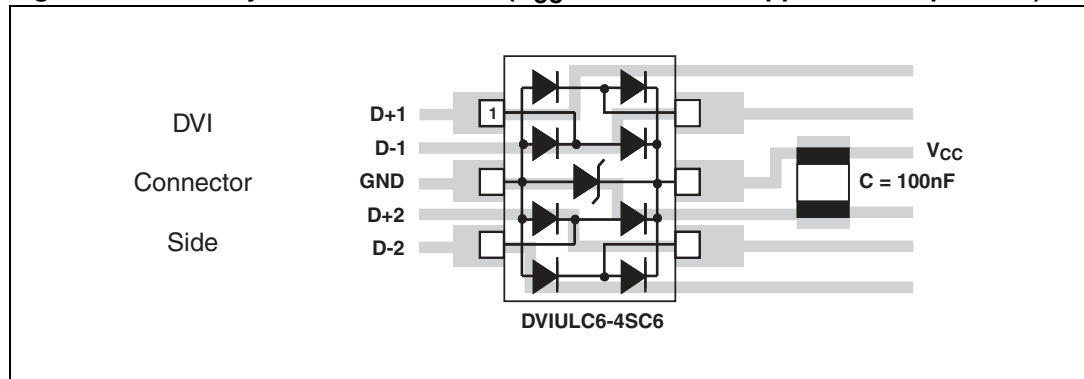

It's often harder to connect the power supply near to the DVIULC6-4SC6 unlike the ground thanks to the ground plane that allows a short connection.

To ensure the same efficiency for positive surges when the connections can't be short enough, we recommend putting close to the DVIULC6-4SC6, between  $V_{BUS}$  and ground, a capacitance of 100 nF to prevent these kinds of disturbances (see [Figure 12](#) and [Figure 13](#)).

The addition of this capacitance will allow a better protection by providing a constant voltage during a surge.

[Figure 14](#), [Figure 6](#), and [Figure 7](#) show the improvement of the ESD protection according to the recommendations described in [Section 3.3](#).

**Figure 14. ESD behavior: measurement conditions (with coupling capacitor)**

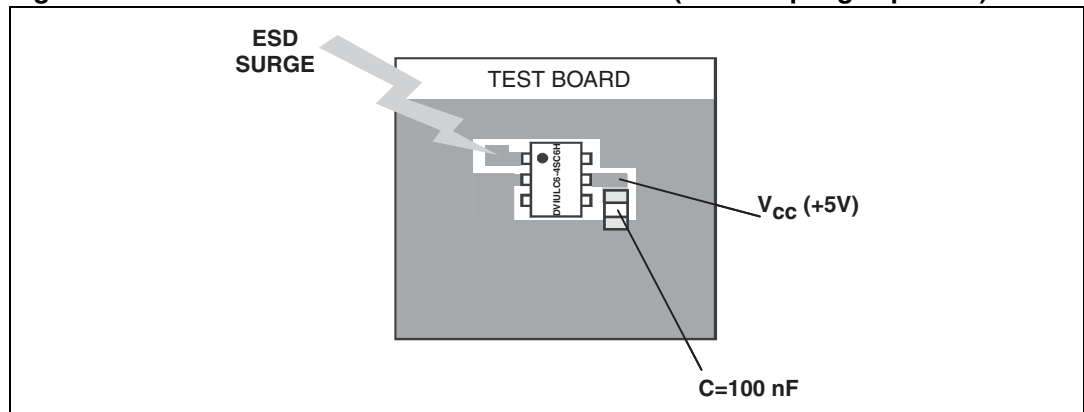

**Important:**

An important precaution to take is to put the protection device as close as possible to the disturbance source (generally the connector).



### 3.4 Crosstalk behavior

Figure 15. Crosstalk phenomena

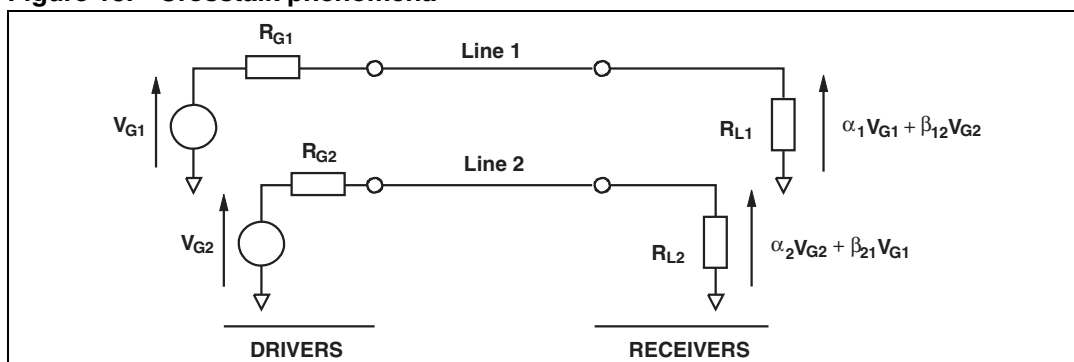

The crosstalk phenomena is due to the coupling between 2 lines. The coupling factor ( $\beta_{12}$  or  $\beta_{21}$ ) increases when the gap across lines decreases, particularly in silicon dice. In the example above the expected signal on load  $R_{L2}$  is  $\alpha_2 V_{G2}$ , in fact the real voltage at this point has got an extra value  $\beta_{21} V_{G1}$ . This part of the  $V_{G1}$  signal represents the effect of the crosstalk phenomenon of line 1 on line 2. This phenomenon has to be taken into account when the drivers impose fast digital data or high frequency analog signals in the disturbing line. The perturbed line will be more affected if it works with low voltage signal or high load impedance (few  $k\Omega$ ).

Figure 16. Analog crosstalk measurements

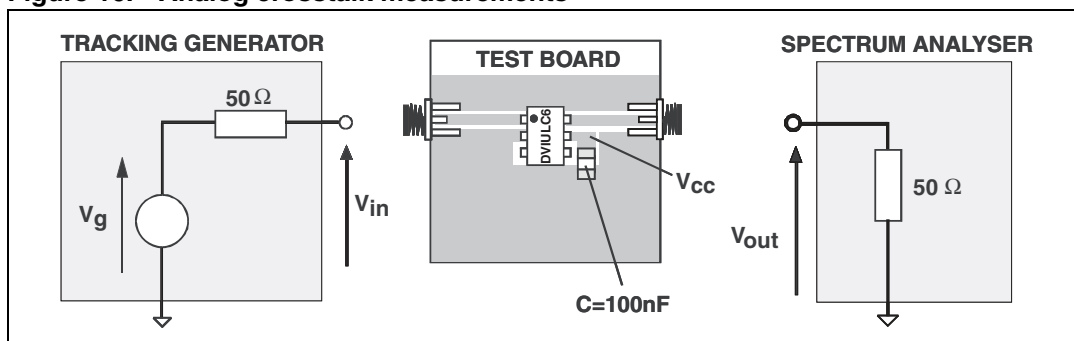

Figure 16 gives the measurement circuit for the analog application. In usual frequency range of analog signals (up to 240 MHz) the effect on disturbed line is less than -45 dB (see Figure 8).

As the DVIULC6-4SC6 is designed to protect high speed data lines, it must ensure a good transmission of operating signals. The frequency response (Figure 5) gives attenuation information and shows that the DVIULC6-4SC6 is well suitable for data line transmission up to 1.65 Gb/s.

## 4 Package information

- Epoxy meets UL94, V0
- Lead-free packages

In order to meet environmental requirements, ST offers these devices in different grades of ECOPACK® packages, depending on their level of environmental compliance. ECOPACK® specifications, grade definitions and product status are available at: [www.st.com](http://www.st.com). ECOPACK® is an ST trademark.

**Table 3. SOT23-6L dimensions**

Ref.	Dimensions					
	Millimeters			Inches		
	Min.	Typ.	Max.	Min.	Typ.	Max.
A	0.90	-	1.45	0.035	-	0.057
A1	0	-	0.15	0	-	0.006
A2	0.90	-	1.30	0.035	-	0.051
b	0.30	-	0.50	0.012	-	0.020
c	0.09	-	0.20	0.004	-	0.008
D	2.80	-	3.05	0.11	-	0.118
E	1.50	-	1.75	0.059	-	0.069
e	-	0.95	-	-	0.037	-
H	2.60	-	3.00	0.102	-	0.118
L	0.30	-	0.60	0.012	-	0.024
θ	0°	-	10°	0°	-	10°

**Figure 17. Footprint - dimensions in mm [inches]**

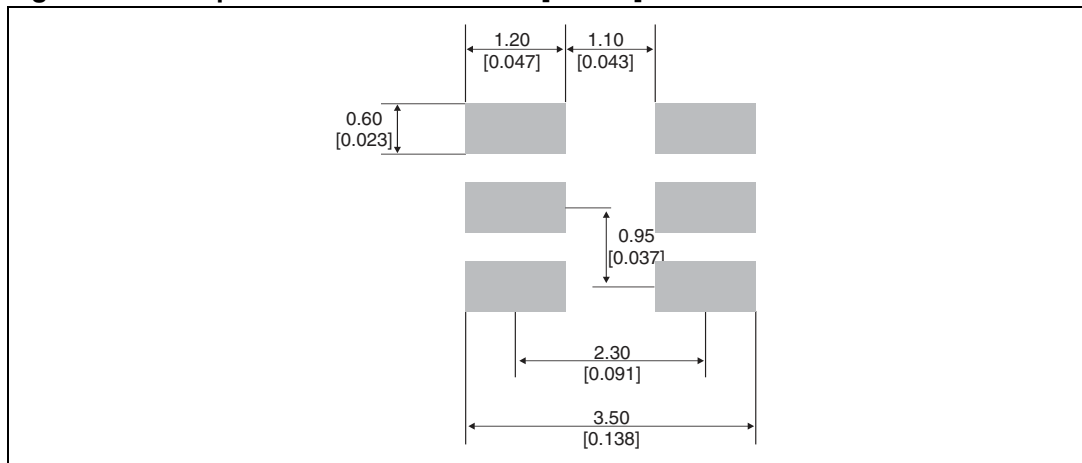

## 5 Ordering information

Table 4. Ordering information

Order code	Marking	Package	Weight	Base qty	Delivery mode
DVIULC6-4SC6	DL46	SOT23-6L	16.7 mg	3000	Tape and reel

## 6 Revision history

Table 5. Document revision history

Date	Revision	Changes
Aug-2005	1	First Issue.
09-Apr-2010	2	ECOPACK statement updated. Operating junction temperature range specified in <a href="#">Table 1</a> .
14-Sep-2011	3	Added peak pulse power in <a href="#">Table 1</a> .
06-Sep-2012	4	Updated illustration and dimensions A1 max., b min., and L min. in <a href="#">Table 3</a> .

**Please Read Carefully:**

Information in this document is provided solely in connection with ST products. STMicroelectronics NV and its subsidiaries ("ST") reserve the right to make changes, corrections, modifications or improvements, to this document, and the products and services described herein at any time, without notice.

All ST products are sold pursuant to ST's terms and conditions of sale.

Purchasers are solely responsible for the choice, selection and use of the ST products and services described herein, and ST assumes no liability whatsoever relating to the choice, selection or use of the ST products and services described herein.

No license, express or implied, by estoppel or otherwise, to any intellectual property rights is granted under this document. If any part of this document refers to any third party products or services it shall not be deemed a license grant by ST for the use of such third party products or services, or any intellectual property contained therein or considered as a warranty covering the use in any manner whatsoever of such third party products or services or any intellectual property contained therein.

**UNLESS OTHERWISE SET FORTH IN ST'S TERMS AND CONDITIONS OF SALE ST DISCLAIMS ANY EXPRESS OR IMPLIED WARRANTY WITH RESPECT TO THE USE AND/OR SALE OF ST PRODUCTS INCLUDING WITHOUT LIMITATION IMPLIED WARRANTIES OF MERCHANTABILITY, FITNESS FOR A PARTICULAR PURPOSE (AND THEIR EQUIVALENTS UNDER THE LAWS OF ANY JURISDICTION), OR INFRINGEMENT OF ANY PATENT, COPYRIGHT OR OTHER INTELLECTUAL PROPERTY RIGHT.**

**UNLESS EXPRESSLY APPROVED IN WRITING BY TWO AUTHORIZED ST REPRESENTATIVES, ST PRODUCTS ARE NOT RECOMMENDED, AUTHORIZED OR WARRANTED FOR USE IN MILITARY, AIR CRAFT, SPACE, LIFE SAVING, OR LIFE SUSTAINING APPLICATIONS, NOR IN PRODUCTS OR SYSTEMS WHERE FAILURE OR MALFUNCTION MAY RESULT IN PERSONAL INJURY, DEATH, OR SEVERE PROPERTY OR ENVIRONMENTAL DAMAGE. ST PRODUCTS WHICH ARE NOT SPECIFIED AS "AUTOMOTIVE GRADE" MAY ONLY BE USED IN AUTOMOTIVE APPLICATIONS AT USER'S OWN RISK.**

Resale of ST products with provisions different from the statements and/or technical features set forth in this document shall immediately void any warranty granted by ST for the ST product or service described herein and shall not create or extend in any manner whatsoever, any liability of ST.

ST and the ST logo are trademarks or registered trademarks of ST in various countries.

Information in this document supersedes and replaces all information previously supplied.

The ST logo is a registered trademark of STMicroelectronics. All other names are the property of their respective owners.

© 2012 STMicroelectronics - All rights reserved

STMicroelectronics group of companies

Australia - Belgium - Brazil - Canada - China - Czech Republic - Finland - France - Germany - Hong Kong - India - Israel - Italy - Japan - Malaysia - Malta - Morocco - Philippines - Singapore - Spain - Sweden - Switzerland - United Kingdom - United States of America

[www.st.com](http://www.st.com)