

- 700MHz min. shift frequency
- Extended 100E VEE range of -4.2V to -5.5V
- 8 bits wide
- Bi-directional
- Four selectable modes for full functionality
- Asynchronous Master Reset
- Fully compatible with industry standard 10KH, 100K ECL levels
- Internal 75KΩ input pulldown resistors
- Fully compatible with Motorola MC10E/100E141
- Pin-compatible with E241
- Available in 28-pin PLCC package

The SY10/100E141 are 8-bit, full-function shift registers designed for use in new, high-performance ECL systems. The E141 performs serial/parallel in and serial/parallel out, shifting in either direction. The eight inputs D₀-D₇ accept parallel input data, while DL/DR accept serial input data for left/right shifting.

The two select pins, SEL₀ and SEL₁ permit four modes of operation: Load, Hold, Shift Left and Shift Right, as shown in the Truth Table. Input data is clocked into the register on the rising clock edge after meeting the minimum set-up time. A logic HIGH on the Master Reset (MR) pin asynchronously resets all the registers to zero.

PIN NAMES

Pin	Function
D ₀ -D ₇	Parallel Data Inputs
DL, DR	Serial Data Inputs
SEL ₀ , SEL ₁	Mode Select Inputs
CLK	Clock
Q ₀ -Q ₇	Data Outputs
MR	Master Reset
V _{CC0}	V _{CC} to Output

BLOCK DIAGRAM

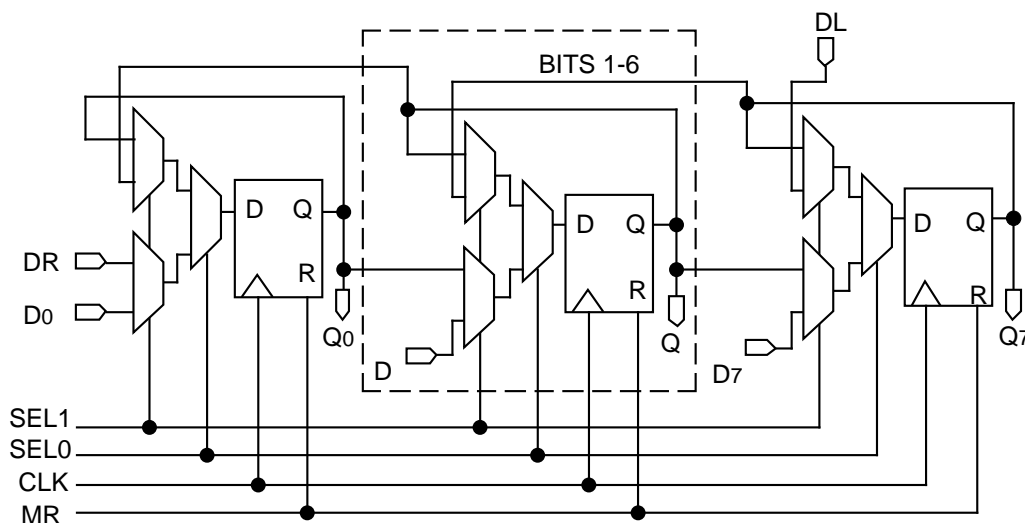

PACKAGE/ORDERING INFORMATION

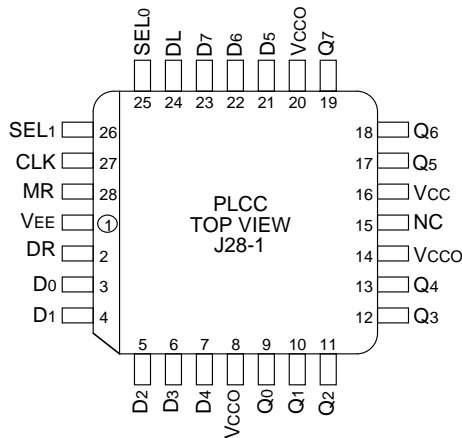

28-Pin PLCC (J28-1)

Ordering Information⁽¹⁾

Part Number	Package Type	Operating Range	Package Marking	Lead Finish
SY10E141JC	J28-1	Commercial	SY10E141JC	Sn-Pb
SY10E141JCTR ⁽²⁾	J28-1	Commercial	SY10E141JC	Sn-Pb
SY100E141JC	J28-1	Commercial	SY100E141JC	Sn-Pb
SY100E141JCTR ⁽²⁾	J28-1	Commercial	SY100E141JC	Sn-Pb
SY10E141JY ⁽³⁾	J28-1	Industrial	SY10E141JY with Pb-Free bar-line indicator	Matte-Sn
SY10E141JYTR ^(2, 3)	J28-1	Industrial	SY10E141JY with Pb-Free bar-line indicator	Matte-Sn
SY100E141JY ⁽³⁾	J28-1	Industrial	SY100E141JY with Pb-Free bar-line indicator	Matte-Sn
SY100E141JYTR ^(2, 3)	J28-1	Industrial	SY100E141JY with Pb-Free bar-line indicator	Matte-Sn

Notes:

1. Contact factory for die availability. Dice are guaranteed at T_A = 25°C, DC Electricals only.
2. Tape and Reel.
3. Pb-Free package is recommended for new designs.

TRUTH TABLE

Function	DL	DR	SEL ₀	SEL ₁	MR	CLK	Q ₀	Q ₁	Q ₂	Q ₃	Q ₄	Q ₅	Q ₆	Q ₇
Load	X	X	L	L	L	Z	D ₀	D ₁	D ₂	D ₃	D ₄	D ₅	D ₆	D ₇
Shift Right	X	L	L	H	L	Z	L	Q ₀	Q ₁	Q ₂	Q ₃	Q ₄	Q ₅	Q ₆
	X	H	L	H	L	Z	H	L	Q ₀	Q ₁	Q ₂	Q ₃	Q ₄	Q ₅
Shift Left	L	X	H	L	L	Z	L	Q ₀	Q ₁	Q ₂	Q ₃	Q ₄	Q ₅	L
	H	X	H	L	L	Z	Q ₀	Q ₁	Q ₂	Q ₃	Q ₄	Q ₅	L	H
Hold	X	X	H	H	L	Z	Q ₀	Q ₁	Q ₂	Q ₃	Q ₄	Q ₅	L	H
	X	X	H	H	L	Z	Q ₀	Q ₁	Q ₂	Q ₃	Q ₄	Q ₅	L	H
Reset	X	X	X	X	H	X	L	L	L	L	L	L	L	L

DC ELECTRICAL CHARACTERISTICSV_{EE} = V_{EE} (Min.) to V_{EE} (Max.); V_{CC} = V_{CCO} = GND

Symbol	Parameter	T _A = 0°C			T _A = +25°C			T _A = +85°C			Unit	Condition
		Min.	Typ.	Max.	Min.	Typ.	Max.	Min.	Typ.	Max.		
I _{IH}	Input HIGH Current	—	—	150	—	—	150	—	—	150	μA	—
I _{EE}	Power Supply Current	—	—	—	—	—	—	—	—	—	mA	—
	10E	—	131	157	—	131	157	—	131	157		
	100E	—	131	157	—	131	157	—	151	181		

AC ELECTRICAL CHARACTERISTICSV_{EE} = V_{EE} (Min.) to V_{EE} (Max.); V_{CC} = V_{CCO} = GND

Symbol	Parameter	T _A = 0°C			T _A = +25°C			T _A = +85°C			Unit	Condition
		Min.	Typ.	Max.	Min.	Typ.	Max.	Min.	Typ.	Max.		
f _{SHIFT}	Max. Shift Frequency	700	900	—	700	900	—	700	900	—	MHz	—
t _{PD}	Propagation Delay to Output CLK MR	625	750	975	625	750	975	625	750	975	ps	—
		600	725	975	600	725	975	600	725	975		
t _s	Set-up Time	—	—	—	—	—	—	—	—	—	ps	—
	D	175	25	—	175	25	—	175	25	—		
	SEL ₀	350	200	—	350	200	—	350	200	—		
t _H	Hold Time	—	—	—	—	—	—	—	—	—	ps	—
	D	200	-25	—	200	-25	—	200	-25	—		
	SEL ₀	100	-200	—	100	-200	—	100	-200	—		
t _{RR}	Reset Recovery Time	900	700	—	900	700	—	900	700	—	ps	—
		—	—	—	—	—	—	—	—	—		
t _{PW}	Minimum Pulse Width CLK, MR	400	—	—	400	—	—	400	—	—	ps	—
t _{skew}	Within-Device Skew	—	60	—	—	60	—	—	60	—	ps	1
t _r	Rise/Fall Time	300	525	800	300	525	800	300	525	800	ps	—
t _f	20% to 80%	—	—	—	—	—	—	—	—	—		

Note:

1. Within-device skew is defined as identical transitions on similar paths through a device.

28-PIN PLCC (J28-1)

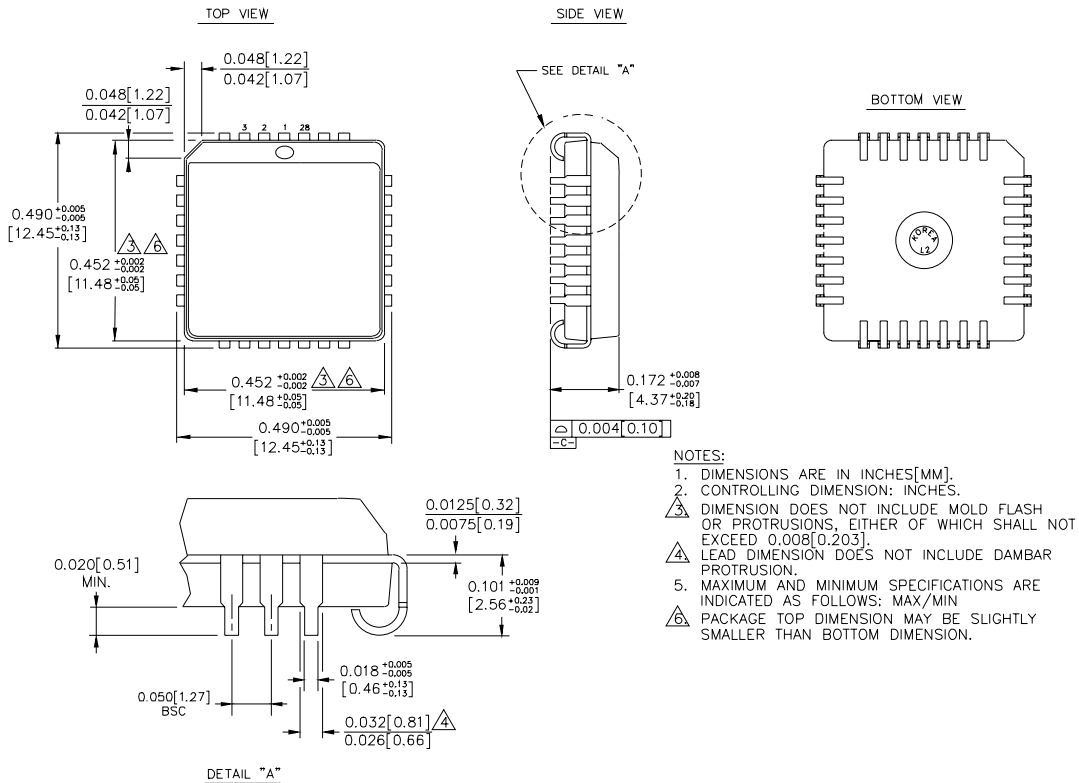

- NOTES:
1. DIMENSIONS ARE IN INCHES[MM].
 2. CONTROLLING DIMENSION: INCHES.
 3. DIMENSION DOES NOT INCLUDE MOLD FLASH OR PROTRUSIONS, EITHER OF WHICH SHALL NOT EXCEED 0.008[0.203].
 4. LEAD DIMENSION DOES NOT INCLUDE DAMBAR PROTRUSION.
 5. MAXIMUM AND MINIMUM SPECIFICATIONS ARE INDICATED AS FOLLOWS: MAX/MIN
 6. PACKAGE TOP DIMENSION MAY BE SLIGHTLY SMALLER THAN BOTTOM DIMENSION.

Rev. 03

MICREL, INC. 2180 FORTUNE DRIVE SAN JOSE, CA 95131 USA

TEL + 1 (408) 944-0800 FAX + 1 (408) 474-1000 WEB <http://www.micrel.com>

The information furnished by Micrel in this data sheet is believed to be accurate and reliable. However, no responsibility is assumed by Micrel for its use. Micrel reserves the right to change circuitry and specifications at any time without notification to the customer.

Micrel Products are not designed or authorized for use as components in life support appliances, devices or systems where malfunction of a product can reasonably be expected to result in personal injury. Life support devices or systems are devices or systems that (a) are intended for surgical implant into the body or (b) support or sustain life, and whose failure to perform can be reasonably expected to result in a significant injury to the user. A Purchaser's use or sale of Micrel Products for use in life support appliances, devices or systems is at Purchaser's own risk and Purchaser agrees to fully indemnify Micrel for any damages resulting from such use or sale.

© 2006 Micrel, Incorporated.