

# ASMT-QxBE-Nxxxx

## Super 0.5W Power PLCC-4 Surface Mount LED Indicator



## Data Sheet



Lead (Pb) Free  
RoHS 6 fully  
compliant



### Description

The Super 0.5W Power PLCC-4 SMT LED is first Blue & Green mid-Power PLCC-4 SMT LEDs using InGaN chip technology. The package can be driven at high current due to its superior package design. The product is able to dissipate the heat more efficiently compared to the Power PLCC-4 SMT LEDs. These LEDs produce higher light output with better flux performance compared to the Power PLCC-4 SMT LED.

The Super 0.5W Power PLCC-4 SMT LEDs are designed for higher reliability, better performance, and operate under a wide range of environmental conditions. The performance characteristics of these new mid-power LEDs make them uniquely suitable for use in harsh conditions such as in automotive applications, and in electronics signs and signals.

To facilitate easy pick and place assembly, the LEDs are packed in EIA-compliant tape and reel. Every reel is shipped in single intensity and color bin, to provide close uniformity.

### Features

- Industry Standard PLCC 4 platform (3.2x2.8x1.9mm)
- High reliability package with enhanced silicone resin encapsulation
- High brightness with optimum flux performance using InGaN chip technologies
- Available in Blue and Green color
- Available in 8mm carrier tape & 7 inch reel
- Low Thermal Resistance 40°C/W
- Super wide viewing angle at 120 degree
- JEDEC MSL 2a

### Applications

1. Electronic signs and signals
  - a. Decorative/Advertising Lighting
  - b. Channel Lettering
  - c. Signs Luminaire
  - d. RGB Backlighting

**CAUTION:** ASMT-QXBE-Nxxxx LEDs are ESD sensitive. Please observe appropriate precautions during handling and processing. Refer to Avago Application Note AN-1142 for additional details.

## Package Drawing

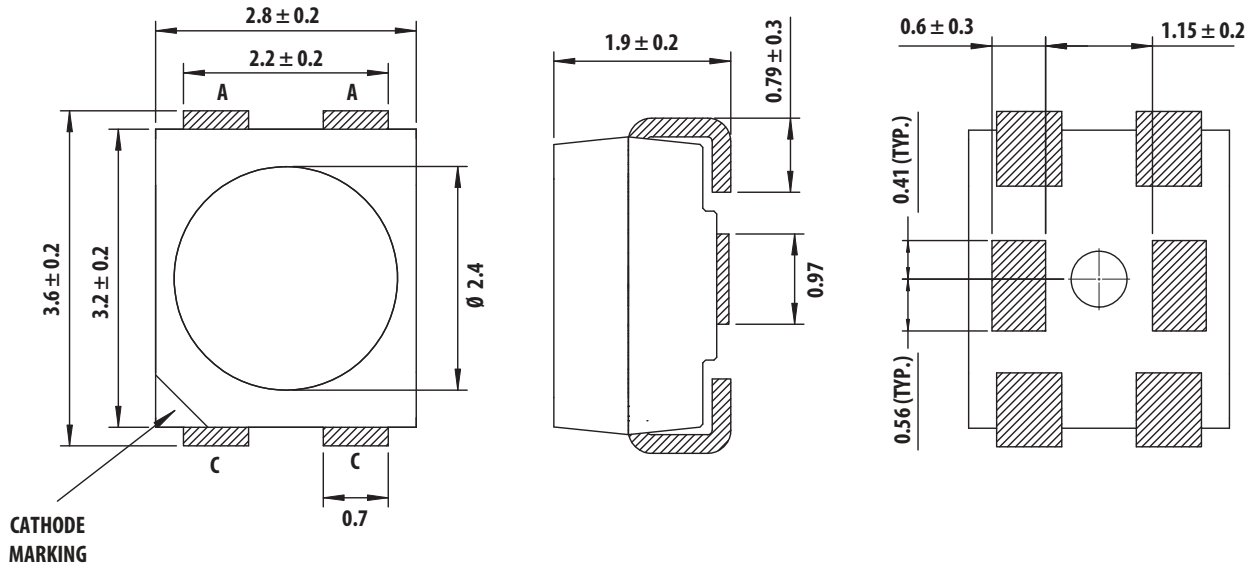

Notes:

1. All dimensions in millimeters
2. Lead polarity as shown in figure 13.
3. Terminal finish: Ag plating.
4. Encapsulation material: silicone resin.

Figure 1. Package Drawing

Table 1. Device Selection Guide

Color	Part Number	Luminous Flux, $\Phi_V^{[1]}$ (lm)			Test Current (mA)	Dice Technology
		Min. Flux (lm)	Typ. Flux (lm)	Max. Flux (lm)		
Blue	ASMT-QBBE-NOB0E	3.4	4.8	7.0	150	InGaN
Green	ASMT-QGBE-NFH0E	15.0	23.0	33.0	150	InGaN
Green	ASMT-QGBE-NGJ0E	19.5	43.0	-	150	InGaN

Notes:

1.  $\Phi_V$  is the total luminous flux output as measured with an integrating sphere at mono pulse conditions.
2. Tolerance =  $\pm 12\%$

## Part Numbering System

ASMT-QX<sub>1</sub>BE-NX<sub>2</sub>X<sub>3</sub>X<sub>4</sub>X<sub>5</sub>

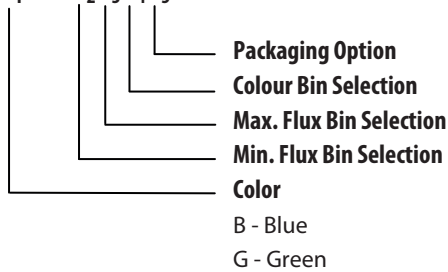

**Table 2. Absolute Maximum Ratings ( $T_A = 25\text{ }^\circ\text{C}$ )**

Parameters	ASMT-QWBE-Nxxxx
DC Forward Current <sup>[1]</sup>	150 mA
Peak Forward Current <sup>[2]</sup>	300 mA
Power Dissipation	513 mW
Reverse Voltage	-4V
Junction Temperature	125 °C
Operating Temperature	-40 °C to +110 °C
Storage Temperature	-40 °C to +110 °C

Notes:

1. Derate Linearly as shown in Figure 6.
2. Duty Factor = 10%, Frequency = 1kHz

**Table 3. Optical Characteristics ( $T_J = 25\text{ }^\circ\text{C}$ )**

Color	Part Number	Dice Technology	Peak Wavelength	Dominant Wavelength $\lambda_D$	Viewing Angle $2\theta_{1/2}$ <sup>[1]</sup>	Luminous Efficiency	Total Flux / Luminous Intensity
			$\lambda_{PEAK}$ (nm)	(nm)	(Degrees)	$\eta_e$ (lm/W)	$\Phi_V$ (lm) / $I_V$ (cd)
			Typ.	Typ.	Typ.	Typ.	Typ.
Blue	ASMT-QBBE-Nxxxx	InGaN	459.0	464.5	120	10	2.75
Green	ASMT-QGBE-Nxxxx	InGaN	516.5	522.0	120	35	2.75

Notes:

1.  $\theta_{1/2}$  is the off-axis angle where the luminous intensity is  $1/2$  the peak intensity.

**Table 4. Electrical Characteristics ( $T_J = 25\text{ }^\circ\text{C}$ )**

Part Number	Forward Voltage VF (Volts) @ IF = 150 mA		Thermal Resistance $R_{\theta J-p}$ ( $^\circ\text{C}/\text{W}$ )
	Typ.	Max.	
ASMT-QBBE-Nxxxx	3.6	4.1	40
ASMT-QBGE-Nxxxx	3.6	4.1	40

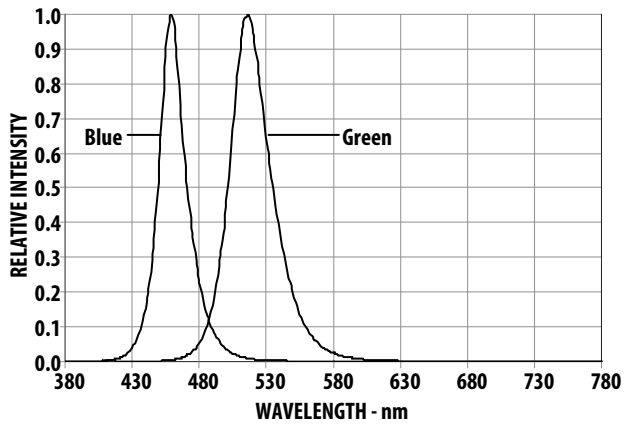

Figure 2. Relative Intensity Vs. Wavelength

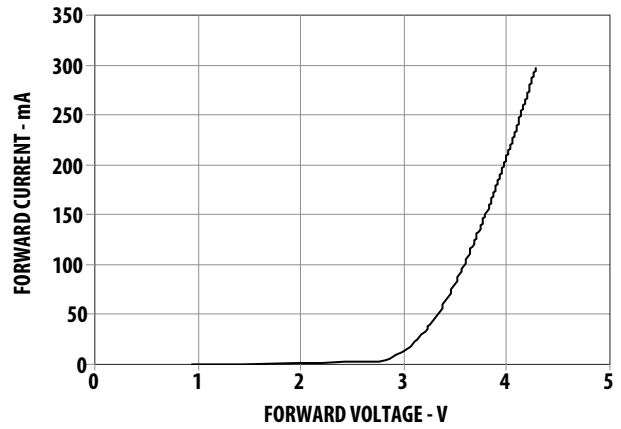

Figure 3. Forward Current Vs. Forward Voltage

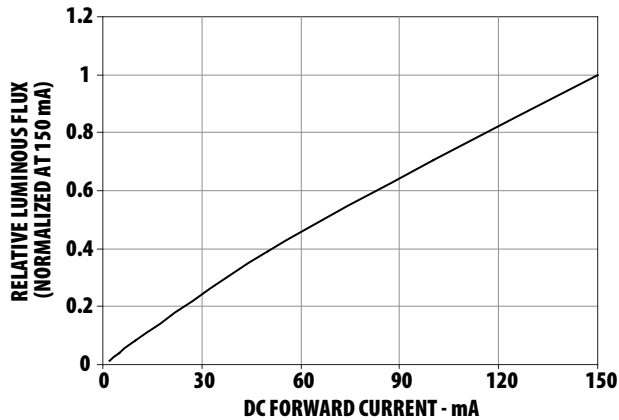

Figure 4. Relative Flux Vs. Forward Current

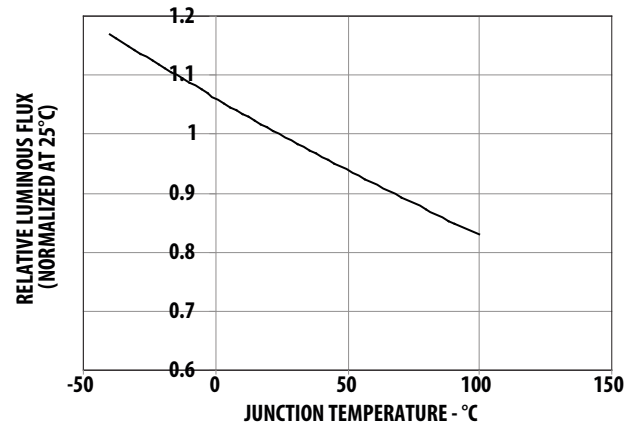

Figure 5. Relative Flux Vs. Temperature

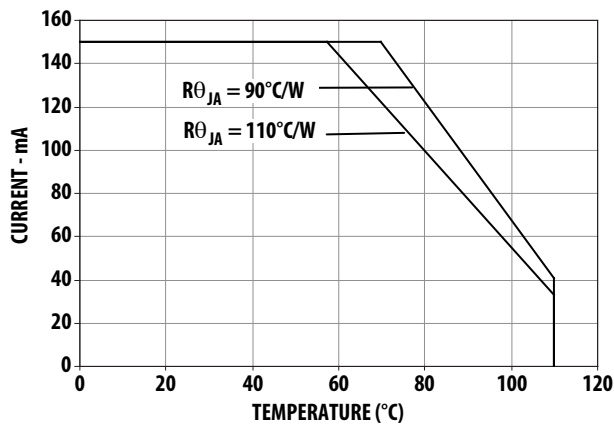

Figure 6a. Maximum Forward Current Vs. Ambient Temperature.  
Derated Based on  $T_{JMAX} = 125^{\circ}C$ ,  $R_{\theta JA} = 110^{\circ}C/W$  &  $90^{\circ}C/W$

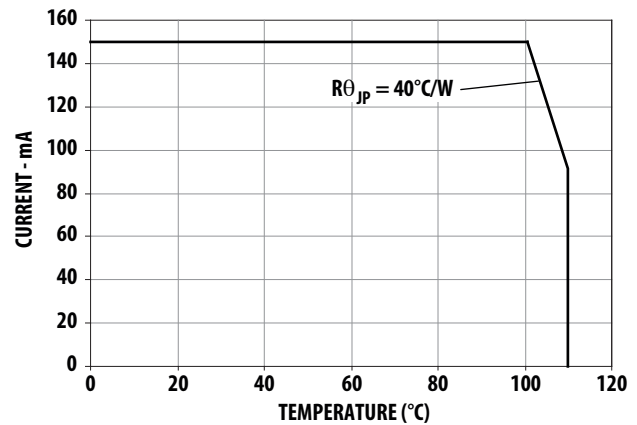

Figure 6b. Maximum Forward Current Vs. Solder Point Temperature.  
Derated Based on  $T_{JMAX} = 125^{\circ}C$ ,  $R_{\theta JP} = 40^{\circ}C/W$ .

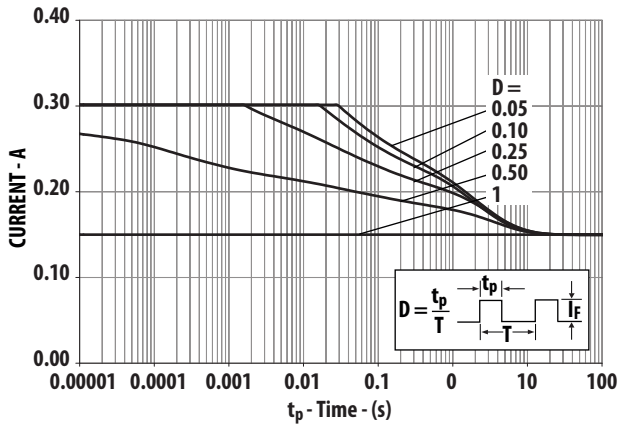

Figure 7a. Maximum Pulse Current Vs. Ambient Temperature. Derated Based on  $T_A = 25^\circ\text{C}$ ,  $R\theta_{J-A} = 110^\circ\text{C/W}$ .

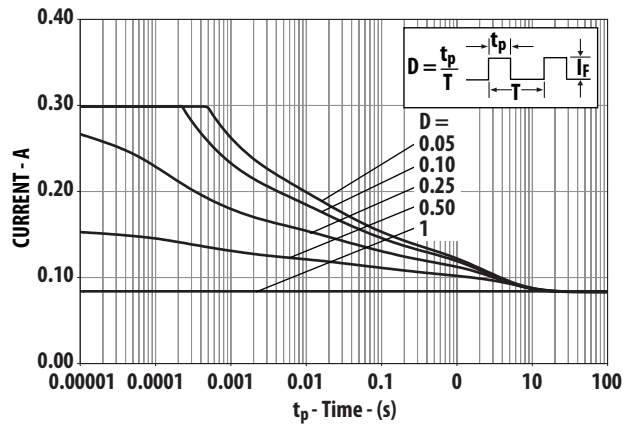

Figure 7b. Maximum Pulse Current Vs. Ambient Temperature. Derated Based on  $T_A = 85^\circ\text{C}$ ,  $R\theta_{J-p} = 110^\circ\text{C/W}$ .

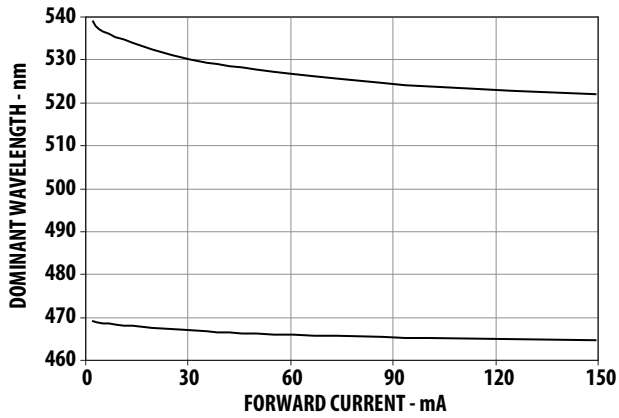

Figure 8. Dominant wavelength Vs. Forward Current.

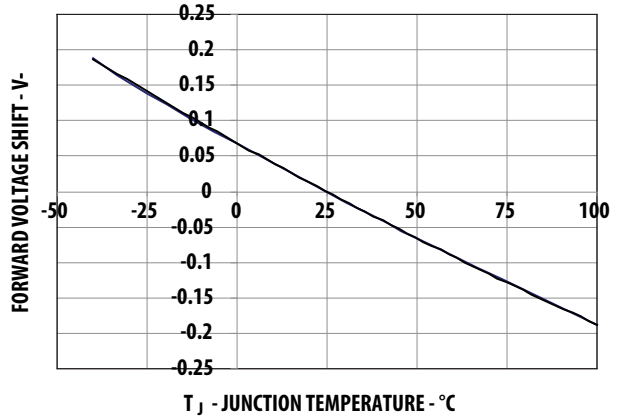

Figure 9. Forward Voltage Shift Vs. Temperature.

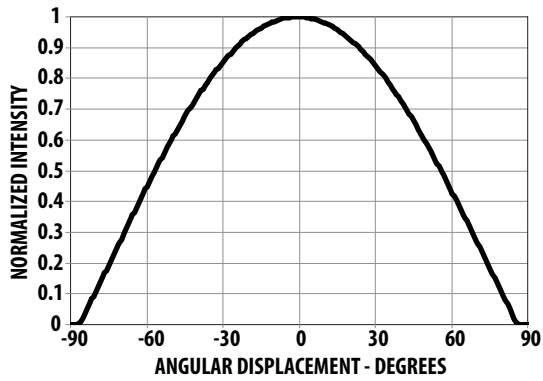
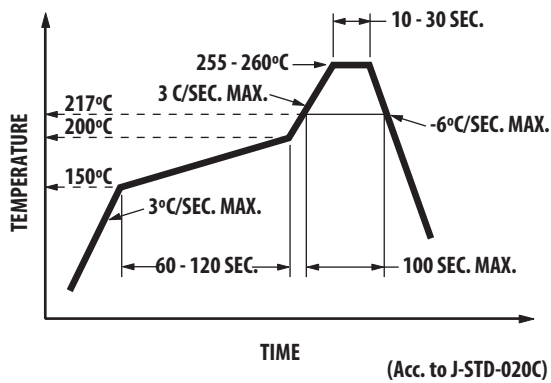

Figure 10. Radiation Pattern



Note: For detail information on reflow soldering of Avago surface mount LEDs, do refer to Avago Application Note AN 1060 Surface Mounting SMT LED Indicator Components.

Figure 11. Recommended Pb-free Reflow Soldering Profile

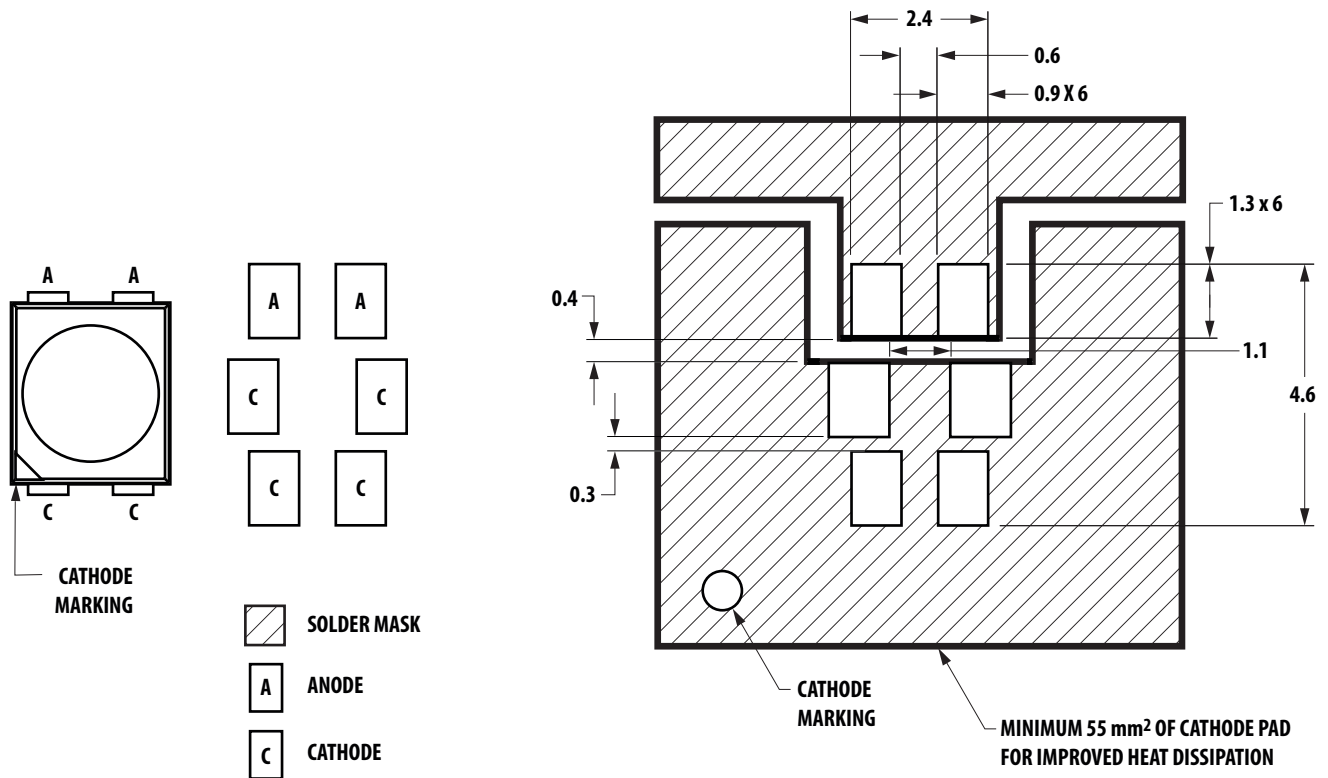

Figure 12. Recommended Soldering Pad Pattern

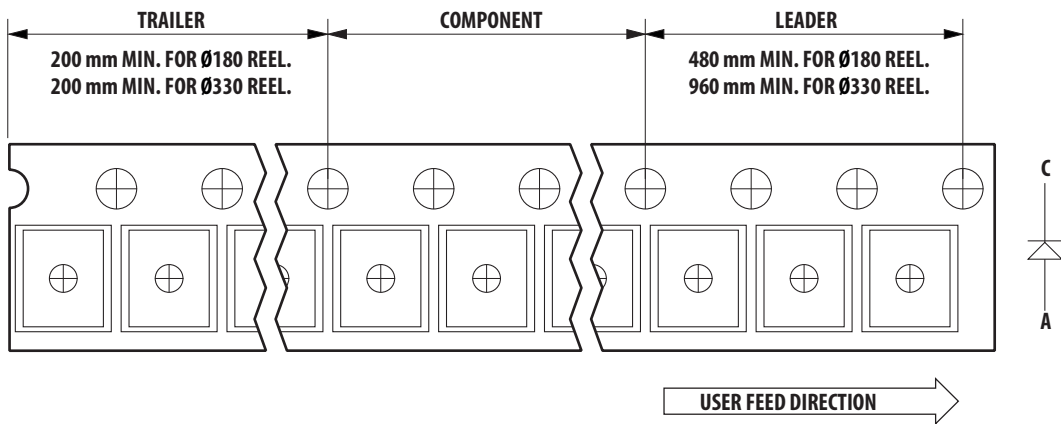

Figure 13. Tape Leader and Trailer Dimensions

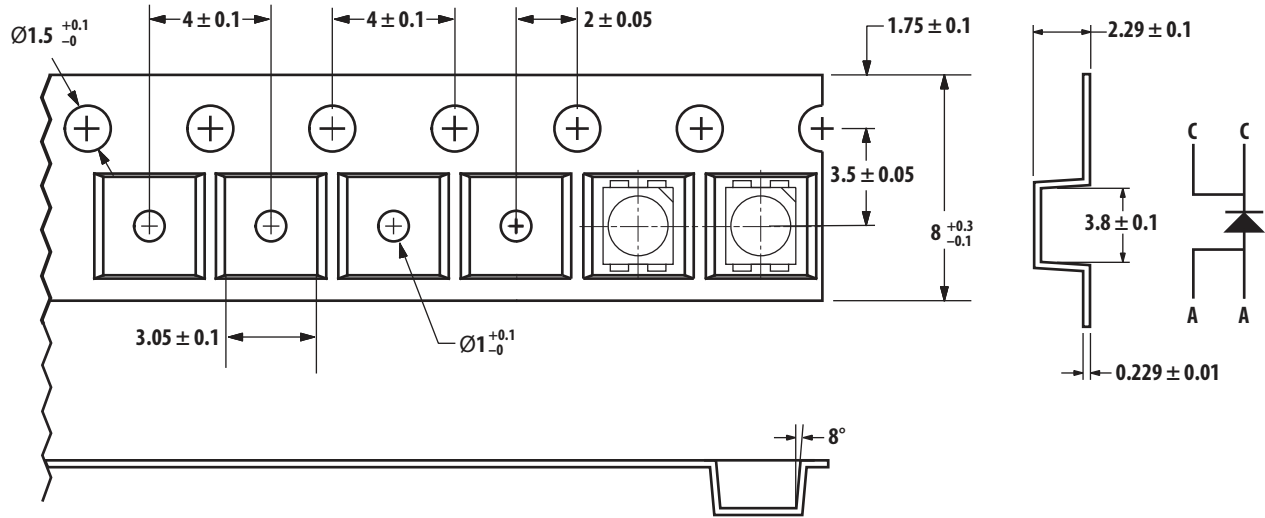

Figure 14. Tape Dimensions

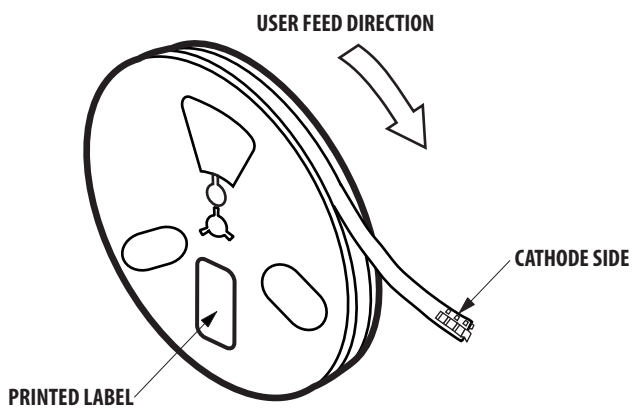
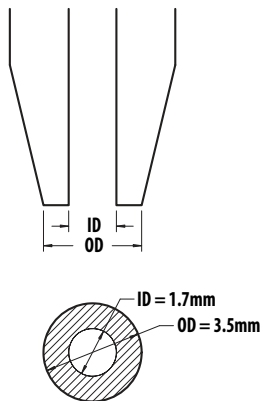

Figure 15. Reeling Orientation

## Handling Precautions

The encapsulation material of the LED is made of silicone for better product reliability. Compared to epoxy encapsulant that is hard and brittle, silicone is softer and flexible. Special handling precautions need to be observed during assembly of silicone encapsulated LED products. Failure to comply might lead to damage and premature failure of the LED. Refer to Application Note AN5288, *Silicone Encapsulation for LED: Advantages and Handling Precautions* for more information.

- Do not poke sharp objects into the silicone encapsulant. Sharp objects like tweezers or syringes might apply excessive force or even pierce through the silicone and induce failures to the LED die or wire bond.
- Do not touch the silicone encapsulant. Uncontrolled force acting on the silicone encapsulant might result in excessive stress on the wire bond. The LED should only be held by the body.
- Do not stack assembled PCBs together. Use an appropriate rack to hold the PCBs.
- Surface of silicone material attracts dust and dirt easier than epoxy due to its surface tackiness. To remove foreign particles on the surface of silicone, a cotton bud can be used with isopropyl alcohol (IPA). During cleaning, rub the surface gently without putting much pressure on the silicone. Ultrasonic cleaning is not recommended.
- For automated pick and place, Avago has tested the nozzle size below to be working fine with this LED. However, due to the possibility of variations in other parameters such as pick and place machine maker/model and other settings of the machine, the customer is recommended to verify the nozzle selected will not cause damage to the LED.



## Moisture Sensitivity

This product has a Moisture Sensitive Level 2a rating per JEDEC J-STD-020. Refer to Avago Application Note AN5305, *Handling of Moisture Sensitive Surface Mount Devices*, for additional details and a review of proper handling procedures.

- Before use:
  - An unopened moisture barrier bag (MBB) can be stored at  $<40^{\circ}\text{C}/90\%\text{RH}$  for 12 months. If the actual shelf life has exceeded 12 months and the humidity Indicator Card (HIC) indicates that baking is not required, then it is safe to reflow the LEDs per the original MSL rating.
  - It is recommended that the MBB not be opened prior to assembly (e.g., for IQC).
- Control after opening the MBB:
  - The humidity indicator card (HIC) shall be read immediately upon opening of MBB.
  - The LEDs must be kept at  $<30^{\circ}\text{C} / 60\%\text{RH}$  at all times, and all high temperature related processes including soldering, curing, or rework need to be completed within 672 hours.
- Control for unfinished reel:
  - Unused LEDs must be stored in a sealed MBB with desiccant or desiccator at  $<5\%\text{RH}$ .
- Control of assembled boards:
  - If the PCB soldered with the LEDs is to be subjected to other high temperature processes, the PCB needs to be stored in sealed MBB with desiccant or desiccator at  $<5\%\text{RH}$  to ensure that all LEDs have not exceeded their floor life of 672 hours.
- Baking is required if:
  - The HIC indicator is not BROWN at 10% and is AZURE at 5%.
  - The LEDs are exposed to condition of  $>30^{\circ}\text{C}/60\%\text{RH}$  at any time.
  - The LED floor life exceeded 168 hours.  
The recommended baking condition is  $60\pm 5^{\circ}\text{C}$  for 20 hours.  
Baking should only be done once.
- Storage:
  - The soldering terminals of these Avago LEDs are silver plated. If the LEDs are being exposed in ambient environment for too long, the silver plating might be oxidized and thus affecting its solderability performance. As such, unused LEDs must be kept in sealed MBB with desiccant or in desiccator at  $<5\%\text{RH}$ .



## Application Precautions

- Drive current of the LED must not exceed the maximum allowable limit across temperature as stated in this data sheet. Constant current driving is recommended to ensure consistent performance.
- LEDs do exhibit slightly different characteristics at different drive current, which might result in larger variation in their performance (i.e., intensity, wavelength, and forward voltage). The user is recommended to set the application current as close as possible to the test current in order to minimize these variations.
- The LED is not intended for reverse bias. Use other appropriate components for such purpose. When driving the LED in matrix form, it is crucial to ensure that the reverse bias voltage is not exceeding the allowable limit of the LED.
- Do not use the LED in the vicinity of material with sulfur content, in an environment of high gaseous sulfur compound and corrosive elements. Examples of material that may contain sulfur are rubber gasket, RTV (room temperature vulcanizing) silicone rubber, rubber gloves, etc. Prolonged exposure to such an environment might affect the optical characteristics and product life.
- Avoid rapid change in ambient temperature especially in a high humidity environment as this will cause condensation on the LED.
- Although the LED is rated as IPx6 according to IEC60529: Degree of protection provided by enclosure, the test condition may not represent actual exposure during application. If the LED is intended to be used in an outdoor or harsh environment, the LED must be protected against damages caused by rain water, dust, oil, corrosive gases, external mechanical stress, etc.

## Thermal Management

Optical, electrical, and reliability characteristics of the LED are affected by temperature. The junction temperature ( $T_J$ ) of the LED must be kept below allowable limit at all times.  $T_J$  can be calculated as below:

$$T_J = T_A + R_{\theta J-A} \times I_F \times V_{Fmax}$$

where:

$T_A$  = ambient temperature [°C]

$R_{\theta J-A}$  = thermal resistance from LED junction to ambient [°C/W]

$I_F$  = forward current [A]

$V_{Fmax}$  = maximum forward voltage [V]

The complication of using this formula lies in  $T_A$  and  $R_{\theta J-A}$ . Actual  $T_A$  is sometimes subjective and hard to

determine.  $R_{\theta J-A}$  varies from system to system depending on design and is usually not known.

Another way of calculating  $T_J$  is by using solder point temperature  $T_S$  as shown below:

$$T_J = T_S + R_{\theta J-S} \times I_F \times V_{Fmax}$$

where:

$T_S$  = LED solder point temperature as shown in the illustration below [°C]

$R_{\theta J-S}$  = thermal resistance from junction to solder point [°C/W]

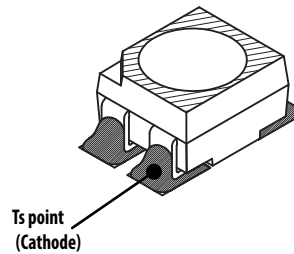

$T_S$  can be measured easily by mounting a thermocouple on the soldering joint as shown in the illustration above, while  $R_{\theta J-S}$  is provided in this data sheet. User is advised to verify the  $T_S$  of the LED in the final product to ensure that the LEDs are operated within all maximum ratings stated in this data sheet.

## Eye Safety Precautions

LEDs may pose optical hazards when in operation. It is not advisable to view directly at operating LEDs as it may be harmful to the eyes. For safety reasons, use appropriate shielding or personal protective equipment.

## Disclaimer

Avago's products are not specifically designed, manufactured, or authorized for sale as parts, components, or assemblies for the planning, construction, maintenance, or direct operation of a nuclear facility or for use in medical devices or applications. The customer is solely responsible, and waives all rights to make claims against Avago or its suppliers, for all loss, damage, expense, or liability in connection with such use.

### Device Color (X<sub>1</sub>)

B	Blue
G	Green

### Flux Bin Select (X<sub>2</sub>X<sub>3</sub>)

Individual reel will contain parts from one bin only

X <sub>2</sub>	Min Flux Bin
X <sub>3</sub>	Max Flux Bin

### Flux Bin Limits

Bin ID	Min. (lm)	Max. (lm)
0	3.40	4.30
A	4.30	5.50
B	5.50	7.00
C	7.00	9.00
D	9.00	11.50
E	11.50	15.00
F	15.00	19.50
G	19.50	25.50
H	25.50	33.00
J	33.00	43.00
K	43.00	56.00
L	56.00	73.00

Tolerance of each bin limit = ± 12%

### Color Bin Select (X<sub>4</sub>)

Individual reel will contain parts from one full bin only.

X <sub>4</sub>	
0	Full Distribution
A	1 and 2 only
B	2 and 3 only
C	3 and 4 only
G	1, 2 and 3 only
H	2, 3 and 4 only
Z	Special binning

### Color Bin Limits

Blue	Min. (nm)	Max. (nm)
1	460.0	465.0
2	465.0	470.0
3	470.0	475.0
4	475.0	480.0

Green	Min. (nm)	Max. (nm)
1	515.0	520.0
2	520.0	525.0
3	525.0	530.0
4	530.0	535.0

Tolerance of each bin limit = ±1 nm

### VF Bin Limits

Bin ID	Min.	Max.
S5	3.20	3.50
S6	3.50	3.80
S7	3.80	4.10

Tolerance of each bin limit = ±0.1V

### Packaging Option (X<sub>5</sub>)

Option	Test Current	Package Type	Reel Size
E	150mA	Top Mount	7 Inch

For product information and a complete list of distributors, please go to our web site: [www.avagotech.com](http://www.avagotech.com)

Avago, Avago Technologies, and the A logo are trademarks of Avago Technologies in the United States and other countries.  
Data subject to change. Copyright © 2005-2016 Avago Technologies. All rights reserved.

AV02-0864EN - August 12, 2016

