

## FEATURES

### SPI interface with error detection

Includes CRC, invalid read/write address, and SCLK count error detection

Supports burst mode and daisy-chain mode

Industry standard SPI Mode 0 and Mode 3 interface compatible

Guaranteed break-before-make switching allowing external wiring of switches to deliver multiplexer configurations

### V<sub>SS</sub> to V<sub>DD</sub> analog signal range

Fully specified at ±15 V, ±20 V, +12 V, and +36 V

±9 V to ±22 V dual-supply operation

9 V to 40 V single-supply operation

Latch-up proof analog switch pins

8 kV HBM ESD rating

Low on resistance (<10 Ω)

1.8 V logic compatibility with 2.7 V ≤ V<sub>L</sub> ≤ 3.3 V

## APPLICATIONS

Relay replacement

Automatic test equipment

Data acquisition

Instrumentation

Avionics

Audio and video switching

Communication systems

## GENERAL DESCRIPTION

The ADGS5412 contains four independent single-pole/single-throw (SPST) switches. A serial peripheral interface (SPI) controls the switches. The SPI interface has robust error detection features, including cyclic redundancy check (CRC) error detection, invalid read/write address detection, and serial clock (SCLK) count error detection.

It is possible to daisy-chain multiple ADGS5412 devices together, which enables the configuration of multiple devices with a minimal amount of digital lines. The ADGS5412 can also operate in burst mode to decrease the time between SPI commands.

Each switch conducts equally well in both directions when on, and each switch has an input signal range that extends to the supplies. In the off condition, signal levels up to the supplies are blocked.

The on-resistance profile is very flat over the full analog input range, which ensures good linearity and low distortion when switching audio signals. The ADGS5412 exhibits break-before-make switching action, allowing use of the device in multiplexer

## FUNCTIONAL BLOCK DIAGRAM

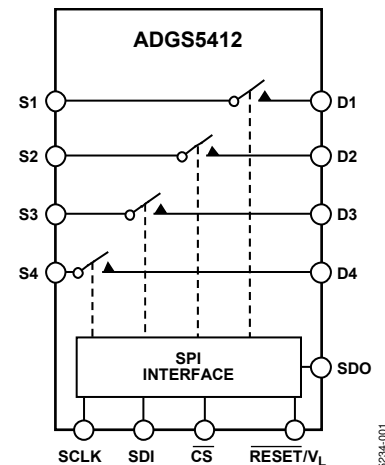

Figure 1.

applications with external wiring.

## PRODUCT HIGHLIGHTS

1. SPI interface removes the need for parallel conversion and logic traces and reduces general-purpose input/output (GPIO) channel count.
2. Daisy-chain mode removes additional logic traces when multiple devices are used.
3. CRC, invalid read/write address, and SCLK count error detection ensure a robust digital interface.
4. CRC error detection capabilities allow for the use of the ADGS5412 in safety critical systems.
5. Guaranteed break-before-make switching allows the use of the ADGS5412 in multiplexer configurations with external wiring.

Trench isolation analog switch section guards against latch-up. A dielectric trench separates the positive (P) and negative (N) channel transistors thereby preventing latch-up even under severe overvoltage conditions.

Rev. A

[Document Feedback](#)

Information furnished by Analog Devices is believed to be accurate and reliable. However, no responsibility is assumed by Analog Devices for its use, nor for any infringements of patents or other rights of third parties that may result from its use. Specifications subject to change without notice. No license is granted by implication or otherwise under any patent or patent rights of Analog Devices. Trademarks and registered trademarks are the property of their respective owners.

## TABLE OF CONTENTS

Features .....	1	Error Detection Features .....	22
Applications .....	1	Clearing the Error Flags Register .....	23
Functional Block Diagram .....	1	Burst Mode .....	23
General Description .....	1	Software Reset .....	23
Product Highlights .....	1	Daisy-Chain Mode .....	23
Revision History .....	2	Power-On Reset .....	24
Specifications .....	3	Break-Before-Make Switching .....	25
±15 V Dual Supply .....	3	Trench Isolation .....	25
±20 V Dual Supply .....	5	Digital Input Buffers .....	25
12 V Single Supply .....	7	Applications Information .....	26
36 V Single Supply .....	9	Power Supply Rails .....	26
Continuous Current per Channel, S <sub>x</sub> or D <sub>x</sub> .....	11	Power Supply Recommendations .....	26
Timing Characteristics .....	11	Register Summary .....	27
Absolute Maximum Ratings .....	13	Register Details .....	28
ESD Caution .....	13	Switch Data Register .....	28
Pin Configurations and Function Descriptions .....	14	Error Configuration Register .....	28
Typical Performance Characteristics .....	15	Error Flags Register .....	29
Test Circuits .....	19	Burst Enable Register .....	29
Terminology .....	21	Software Reset Register .....	29
Theory of Operation .....	22	Outline Dimensions .....	30
Address Mode .....	22	Ordering Guide .....	30

## REVISION HISTORY

### 7/2018—Rev. 0 to Rev. A

Changes to Table 1 .....	3
Changes to Source Off Leakage, I <sub>s</sub> (Off) Parameter and Drain Off Leakage, I <sub>D</sub> (Off) Parameter, Table 1 .....	3
Changes to Source Off Leakage, I <sub>s</sub> (Off) Parameter and Drain Off Leakage, I <sub>D</sub> (Off) Parameter, Table 2 .....	5
Changes to Source Off Leakage, I <sub>s</sub> (Off) Parameter and Drain Off Leakage, I <sub>D</sub> (Off) Parameter, Table 4 .....	9
Deleted Figure 43 and Figure 44; Renumbered Sequentially .....	24
Added Figure 43 and Figure 44; Renumbered Sequentially .....	24

### 5/2017—Revision 0: Initial Version

## SPECIFICATIONS

### ±15 V DUAL SUPPLY

Positive supply ( $V_{DD}$ ) = 15 V ± 10%, negative supply ( $V_{SS}$ ) = -15 V ± 10%, digital supply ( $V_L$ ) = 2.7 V to 5.5 V, GND = 0 V, unless otherwise noted.

Table 1.

Parameter	+25°C	-40°C to +85°C	-40°C to +125°C	Unit	Test Conditions/Comments
<b>ANALOG SWITCH</b>					
Analog Signal Range			$V_{DD}$ to $V_{SS}$	V	
On Resistance, $R_{ON}$	9.8			Ω typ	$V_S = \pm 10$ V, $I_S = -10$ mA; see Figure 29
On-Resistance Match Between Channels, $\Delta R_{ON}$	11	14	16	Ω max	$V_{DD} = +13.5$ V, $V_{SS} = -13.5$ V $V_S = \pm 10$ V, $I_S = -10$ mA
On-Resistance Flatness, $R_{FLAT(ON)}$	0.35			Ω typ	
	0.7	0.9	1.1	Ω max	
	1.2			Ω typ	$V_S = \pm 10$ V, $I_S = -10$ mA
	1.6	2	2.2	Ω max	
<b>LEAKAGE CURRENTS</b>					
Source Off Leakage, $I_S$ (Off)	±0.05			nA typ	$V_{DD} = +16.5$ V, $V_{SS} = -16.5$ V $V_S = \pm 10$ V, $V_D = \mu 10$ V; see Figure 32
Drain Off Leakage, $I_D$ (Off)	±0.25	±0.75	±6	nA max	
	±0.05			nA typ	$V_S = \pm 10$ V, $V_D = \mu 10$ V; see Figure 32
Channel On Leakage, $I_D$ (On), $I_S$ (On)	±0.25	±0.75	±6	nA max	
	±0.1			nA typ	$V_S = V_D = \pm 10$ V; see Figure 28
	±0.4	±2	±12	nA max	
<b>DIGITAL OUTPUT</b>					
Output Voltage Low, $V_{OL}$			0.4	V max	$I_{SINK} = 5$ mA
High Impedance Leakage Current	0.001		0.2	V max	$I_{SINK} = 1$ mA
High Impedance Output Capacitance	4		±0.1	μA typ	$V_{OUT} = V_{GND}$ or $V_L$
				μA max	
				pF typ	
<b>DIGITAL INPUTS</b>					
Input Voltage High, $V_{INH}$			2	V min	$3.3$ V < $V_L \leq 5.5$ V
Input Voltage Low, $V_{INL}$			1.35	V min	$2.7$ V < $V_L \leq 3.3$ V
Input Current, $I_{INL}$ or $I_{INH}$	0.002		0.8	V max	$3.3$ V < $V_L \leq 5.5$ V
			0.8	V max	$2.7$ V < $V_L \leq 3.3$ V
Digital Input Capacitance, $C_{IN}$	4		±0.1	μA typ	$V_{IN} = V_{GND}$ or $V_L$
				μA max	
				pF typ	
<b>DYNAMIC CHARACTERISTICS<sup>1</sup></b>					
$t_{ON}$	460			ns typ	$R_L = 300$ Ω, $C_L = 35$ pF
	540	560	580	ns max	$V_S = 10$ V; see Figure 36
$t_{OFF}$	185			ns typ	$R_L = 300$ Ω, $C_L = 35$ pF
	225	240	270	ns max	$V_S = 10$ V; see Figure 36
Break-Before-Make Time Delay, $t_D$	245			ns typ	$R_L = 300$ Ω, $C_L = 35$ pF
			195	ns min	$V_{S1} = V_{S2} = 10$ V, see Figure 35

Parameter	+25°C	-40°C to +85°C	-40°C to +125°C	Unit	Test Conditions/Comments
Charge Injection, $Q_{INJ}$	245			pC typ	$V_S = 0\text{ V}$ , $R_S = 0\ \Omega$ , $C_L = 1\ \text{nF}$ ; see Figure 37
Off Isolation	-78			dB typ	$R_L = 50\ \Omega$ , $C_L = 5\ \text{pF}$ , $f = 100\ \text{kHz}$ ; see Figure 31
Channel to Channel Crosstalk	-70			dB typ	$R_L = 50\ \Omega$ , $C_L = 5\ \text{pF}$ , $f = 1\ \text{MHz}$ ; see Figure 30
Total Harmonic Distortion + Noise, THD + N	0.01			% typ	$R_L = 1\ \text{k}\Omega$ , $15\ \text{V p-p}$ , $f = 20\ \text{Hz}$ to $20\ \text{kHz}$ ; see Figure 33
-3 dB Bandwidth	167			MHz typ	$R_L = 50\ \Omega$ , $C_L = 5\ \text{pF}$ ; see Figure 34
Insertion Loss	-0.7			dB typ	$R_L = 50\ \Omega$ , $C_L = 5\ \text{pF}$ , $f = 1\ \text{MHz}$ ; see Figure 34
Off Switch Source Capacitance, $C_S$ (Off)	18			pF typ	$V_S = 0\ \text{V}$ , $f = 1\ \text{MHz}$
Off Switch Drain Capacitance, $C_D$ (Off)	18			pF typ	$V_S = 0\ \text{V}$ , $f = 1\ \text{MHz}$
On Switch Capacitance, $C_D$ (On), $C_S$ (On)	57			pF typ	$V_S = 0\ \text{V}$ , $f = 1\ \text{MHz}$
<b>POWER REQUIREMENTS</b>					
Positive Supply Current, $I_{DD}$	45			$\mu\text{A typ}$	$V_{DD} = +16.5\ \text{V}$ , $V_{SS} = -16.5\ \text{V}$ Digital inputs = $0\ \text{V}$ or $V_L$
	55		70	$\mu\text{A max}$	
	45			$\mu\text{A typ}$	
	110			$\mu\text{A typ}$	
Digital Supply Current, $I_L$ Inactive	6.3			$\mu\text{A typ}$	Digital inputs = $0\ \text{V}$ or $V_L$
			8.0	$\mu\text{A max}$	
Inactive, SCLK = 1 MHz	14			$\mu\text{A typ}$	$\overline{CS} = V_L$ and $SDI = 0\ \text{V}$ or $V_L$ , $V_L = 5\ \text{V}$
	7			$\mu\text{A typ}$	$\overline{CS} = V_L$ and $SDI = 0\ \text{V}$ or $V_L$ , $V_L = 3\ \text{V}$
SCLK = 50 MHz	390			$\mu\text{A typ}$	$\overline{CS} = V_L$ and $SDI = 0\ \text{V}$ or $V_L$ , $V_L = 5\ \text{V}$
	210			$\mu\text{A typ}$	$\overline{CS} = V_L$ and $SDI = 0\ \text{V}$ or $V_L$ , $V_L = 3\ \text{V}$
Inactive, SDI = 1 MHz	15			$\mu\text{A typ}$	$\overline{CS}$ and $SCLK = 0\ \text{V}$ or $V_L$ , $V_L = 5\ \text{V}$
	7.5			$\mu\text{A typ}$	$\overline{CS}$ and $SCLK = 0\ \text{V}$ or $V_L$ , $V_L = 3\ \text{V}$
SDI = 25 MHz	230			$\mu\text{A typ}$	$\overline{CS}$ and $SCLK = 0\ \text{V}$ or $V_L$ , $V_L = 5\ \text{V}$
	120			$\mu\text{A typ}$	$\overline{CS}$ and $SCLK = 0\ \text{V}$ or $V_L$ , $V_L = 3\ \text{V}$
Active at 50 MHz	1.8			mA typ	Digital inputs toggle between $0\ \text{V}$ and $V_L$ , $V_L = 5.5\ \text{V}$
	0.7		2.1	mA max	Digital inputs toggle between $0\ \text{V}$ and $V_L$ , $V_L = 2.7\ \text{V}$
Negative Supply Current, $I_{SS}$	0.001		1.0	mA max	Digital inputs = $0\ \text{V}$ or $V_L$
			1.0	$\mu\text{A typ}$	
$V_{DD}/V_{SS}$			$\pm 9/\pm 22$	V min/V max	GND = $0\ \text{V}$

<sup>1</sup> Guaranteed by design; not subject to production test.

**±20 V DUAL SUPPLY**

$V_{DD} = 20\text{ V} \pm 10\%$ ,  $V_{SS} = -20\text{ V} \pm 10\%$ ,  $V_L = 2.7\text{ V to } 5.5\text{ V}$ ,  $GND = 0\text{ V}$ , unless otherwise noted.

**Table 2.**

Parameter	+25°C	-40°C to +85°C	-40°C to +125°C	Unit	Test Conditions/Comments
<b>ANALOG SWITCH</b>					
Analog Signal Range			$V_{DD}$ to $V_{SS}$	V	
On Resistance, $R_{ON}$	9			$\Omega$ typ	$V_S = \pm 15\text{ V}$ , $I_S = -10\text{ mA}$ ; see Figure 29
On-Resistance Match Between Channels, $\Delta R_{ON}$	10	13	15	$\Omega$ max	$V_{DD} = +18\text{ V}$ , $V_{SS} = -18\text{ V}$
	0.35			$\Omega$ typ	$V_S = \pm 15\text{ V}$ , $I_S = -10\text{ mA}$
On-Resistance Flatness, $R_{FLAT(ON)}$	0.7	0.9	1.1	$\Omega$ max	
	1.6			$\Omega$ typ	$V_S = \pm 15\text{ V}$ , $I_S = -10\text{ mA}$
	1.9	2.3	2.7	$\Omega$ max	
<b>LEAKAGE CURRENTS</b>					
Source Off Leakage, $I_S$ (Off)	$\pm 0.05$			nA typ	$V_{DD} = +22\text{ V}$ , $V_{SS} = -22\text{ V}$ $V_S = \pm 15\text{ V}$ , $V_D = \mu 15\text{ V}$ ; see Figure 32
Drain Off Leakage, $I_D$ (Off)	$\pm 0.25$	$\pm 0.75$	$\pm 6$	nA max	
	$\pm 0.05$			nA typ	$V_S = \pm 15\text{ V}$ , $V_D = \mu 15\text{ V}$ ; see Figure 32
Channel On Leakage, $I_D$ (On), $I_S$ (On)	$\pm 0.25$	$\pm 0.75$	$\pm 6$	nA max	
	$\pm 0.1$			nA typ	$V_S = V_D = \pm 15\text{ V}$ ; see Figure 28
	$\pm 0.4$	$\pm 2$	$\pm 12$	nA max	
<b>DIGITAL OUTPUT</b>					
Output Voltage Low, $V_{OL}$			0.4	V max	$I_{SINK} = 5\text{ mA}$
			0.2	V max	$I_{SINK} = 1\text{ mA}$
High Impedance Leakage Current	0.001			$\mu\text{A}$ typ	$V_{OUT} = V_{GND}$ or $V_L$
High Impedance Output Capacitance			$\pm 0.1$	$\mu\text{A}$ max	
	4			pF typ	
<b>DIGITAL INPUTS</b>					
Input Voltage High, $V_{INH}$			2	V min	$3.3\text{ V} < V_L \leq 5.5\text{ V}$
			1.35	V min	$2.7\text{ V} \leq V_L \leq 3.3\text{ V}$
Input Voltage Low, $V_{INL}$			0.8	V max	$3.3\text{ V} < V_L \leq 5.5\text{ V}$
			0.8	V max	$2.7\text{ V} \leq V_L \leq 3.3\text{ V}$
Input Current, $I_{INL}$ or $I_{INH}$	0.002			$\mu\text{A}$ typ	$V_{IN} = V_{GND}$ or $V_L$
Digital Input Capacitance, $C_{IN}$	4		$\pm 0.1$	$\mu\text{A}$ max	
				pF typ	

Parameter	+25°C	-40°C to +85°C	-40°C to +125°C	Unit	Test Conditions/Comments
<b>DYNAMIC CHARACTERISTICS<sup>1</sup></b>					
$t_{ON}$	450			ns typ	$R_L = 300 \Omega$ , $C_L = 35$ pF
	530	540	555	ns max	$V_S = 10$ V; see Figure 36
$t_{OFF}$	185			ns typ	$R_L = 300 \Omega$ , $C_L = 35$ pF
	230	245	260	ns max	$V_S = 10$ V; see Figure 36
Break-Before-Make Time Delay, $t_D$	235			ns typ	$R_L = 300 \Omega$ , $C_L = 35$ pF
Charge Injection, $Q_{INJ}$	310		185	ns min	$V_{S1} = V_{S2} = 10$ V, see Figure 35
Off Isolation	-78			pC typ	$V_S = 0$ V, $R_S = 0 \Omega$ , $C_L = 1$ nF; see Figure 37
Channel-to-Channel Crosstalk	-70			dB typ	$R_L = 50 \Omega$ , $C_L = 5$ pF, $f = 100$ kHz; see Figure 31
Total Harmonic Distortion + Noise, THD + N	0.008			dB typ	$R_L = 50 \Omega$ , $C_L = 5$ pF, $f = 1$ MHz; see Figure 30
-3 dB Bandwidth	160			% typ	$R_L = 1$ k $\Omega$ , 20 V p-p, $f = 20$ Hz to 20 kHz; see Figure 33
Insertion Loss	-0.6			MHz typ	$R_L = 50 \Omega$ , $C_L = 5$ pF; see Figure 34
Off Switch Source Capacitance, $C_S$ (Off)	17			dB typ	$R_L = 50 \Omega$ , $C_L = 5$ pF, $f = 1$ MHz; see Figure 34
Off Switch Drain Capacitance, $C_D$ (Off)	17			pF typ	$V_S = 0$ V, $f = 1$ MHz
On Switch Capacitance, $C_D$ (On), $C_S$ (On)	56			pF typ	$V_S = 0$ V, $f = 1$ MHz
<b>POWER REQUIREMENTS</b>					
Positive Supply Current, $I_{DD}$	50			$\mu$ A typ	$V_{DD} = +22$ V, $V_{SS} = -22$ V
	70		110	$\mu$ A max	Digital inputs = 0 V or $V_L$
	50			$\mu$ A typ	All switches closed, $V_L = 5.5$ V
	120			$\mu$ A typ	All switches closed, $V_L = 2.7$ V
$I_L$					
	Inactive	6.3		$\mu$ A typ	Digital inputs = 0 V or $V_L$
Inactive, SCLK = 1 MHz			8.0	$\mu$ A max	
		14		$\mu$ A typ	$\overline{CS} = V_L$ and SDI = 0 V or $V_L$ , $V_L = 5$ V
SCLK = 50 MHz		7		$\mu$ A typ	$\overline{CS} = V_L$ and SDI = 0 V or $V_L$ , $V_L = 3$ V
		390		$\mu$ A typ	$\overline{CS} = V_L$ and SDI = 0 V or $V_L$ , $V_L = 5$ V
Inactive, SDI = 1 MHz		210		$\mu$ A typ	$\overline{CS} = V_L$ and SDI = 0 V or $V_L$ , $V_L = 3$ V
		15		$\mu$ A typ	$\overline{CS}$ and SCLK = 0 V or $V_L$ , $V_L = 5$ V
SDI = 25 MHz		7.5		$\mu$ A typ	$\overline{CS}$ and SCLK = 0 V or $V_L$ , $V_L = 3$ V
		230		$\mu$ A typ	$\overline{CS}$ and SCLK = 0 V or $V_L$ , $V_L = 5$ V
Active at 50 MHz		120		$\mu$ A typ	$\overline{CS}$ and SCLK = 0 V or $V_L$ , $V_L = 3$ V
		1.8		mA typ	Digital inputs toggle between 0 V and $V_L$ , $V_L = 5.5$ V
Negative Supply Current, $I_{SS}$			2.1	mA max	
		0.7		mA typ	Digital inputs toggle between 0 V and $V_L$ , $V_L = 2.7$ V
$V_{DD}/V_{SS}$			1.0	mA max	
		0.001		$\mu$ A typ	Digital inputs = 0 V or $V_L$
			1.0	$\mu$ A max	
			$\pm 9/\pm 22$	V min/V max	GND = 0 V

<sup>1</sup> Guaranteed by design; not subject to production test.

**12 V SINGLE SUPPLY**

$V_{DD} = 12\text{ V} \pm 10\%$ ,  $V_{SS} = 0\text{ V}$ ,  $V_L = 2.7\text{ V}$  to  $5.5\text{ V}$ ,  $GND = 0\text{ V}$ , unless otherwise noted.

**Table 3.**

Parameter	+25°C	-40°C to +85°C	-40°C to +125°C	Unit	Test Conditions/Comments
<b>ANALOG SWITCH</b>					
Analog Signal Range			0 V to $V_{DD}$	V	
On-Resistance, $R_{ON}$	19			$\Omega$ typ	$V_S = 0\text{ V}$ to $10\text{ V}$ , $I_S = -10\text{ mA}$ ; see Figure 29
On-Resistance Match Between Channels, $\Delta R_{ON}$	22 0.4	27	31	$\Omega$ max $\Omega$ typ	$V_{DD} = 10.8\text{ V}$ , $V_{SS} = 0\text{ V}$ $V_S = 0\text{ V}$ to $10\text{ V}$ , $I_S = -10\text{ mA}$
On-Resistance Flatness, $R_{FLAT(ON)}$	0.8 4.4 5.5	1 6.5	1.2 7.5	$\Omega$ max $\Omega$ typ $\Omega$ max	$V_S = 0\text{ V}$ to $10\text{ V}$ , $I_S = -10\text{ mA}$
<b>LEAKAGE CURRENTS</b>					
Source Off Leakage, $I_S$ (Off)	$\pm 0.05$			nA typ	$V_{DD} = 13.2\text{ V}$ , $V_{SS} = 0\text{ V}$ $V_S = 1\text{ V}/10\text{ V}$ , $V_D = 10\text{ V}/1\text{ V}$ ; see Figure 32
Drain Off Leakage, $I_D$ (Off)	$\pm 0.25$ $\pm 0.05$	$\pm 0.75$	$\pm 6$	nA max nA typ	$V_S = 1\text{ V}/10\text{ V}$ , $V_D = 10\text{ V}/1\text{ V}$ ; see Figure 32
Channel On Leakage, $I_D$ (On), $I_S$ (On)	$\pm 0.25$ $\pm 0.1$	$\pm 0.75$	$\pm 6$	nA max nA typ	$V_S = V_D = 1\text{ V}/10\text{ V}$ ; see Figure 28
	$\pm 0.4$	$\pm 2$	$\pm 12$	nA max	
<b>DIGITAL OUTPUT</b>					
Output Voltage Low, $V_{OL}$			0.4 0.2	V max V max	$I_{SINK} = 5\text{ mA}$ $I_{SINK} = 1\text{ mA}$
High Impedance Leakage Current	0.002		$\pm 0.1$	$\mu\text{A}$ typ $\mu\text{A}$ max	$V_{OUT} = V_{GND}$ or $V_L$
High Impedance Output Capacitance	4			pF typ	
<b>DIGITAL INPUTS</b>					
Input Voltage High, $V_{INH}$			2 1.35	V min V min	$3.3\text{ V} < V_L \leq 5.5\text{ V}$ $2.7\text{ V} \leq V_L \leq 3.3\text{ V}$
Input Voltage Low, $V_{INL}$			0.8 0.8	V max V max	$3.3\text{ V} < V_L \leq 5.5\text{ V}$ $2.7\text{ V} \leq V_L \leq 3.3\text{ V}$
Input Current, $I_{INL}$ or $I_{INH}$	0.001		$\pm 0.1$	$\mu\text{A}$ typ $\mu\text{A}$ max	$V_{IN} = V_{GND}$ or $V_L$
Digital Input Capacitance, $C_{IN}$	4			pF typ	
<b>DYNAMIC CHARACTERISTICS<sup>1</sup></b>					
$t_{ON}$	545 665	720	775	ns typ ns max	$R_L = 300\ \Omega$ , $C_L = 35\text{ pF}$ $V_S = 8\text{ V}$ ; see Figure 36
$t_{OFF}$	200 250	275	305	ns typ ns max	$R_L = 300\ \Omega$ , $C_L = 35\text{ pF}$ $V_S = 8\text{ V}$ ; see Figure 36
Break-Before-Make Time Delay, $t_D$	320			ns typ	$R_L = 300\ \Omega$ , $C_L = 35\text{ pF}$
Charge Injection, $Q_{INJ}$	105		235	ns min pC typ	$V_{S1} = V_{S2} = 8\text{ V}$ , see Figure 35 $V_S = 6\text{ V}$ , $R_S = 0\ \Omega$ , $C_L = 1\text{ nF}$ ; see Figure 37
Off Isolation	-78			dB typ	$R_L = 50\ \Omega$ , $C_L = 5\text{ pF}$ , $f = 100\text{ kHz}$ ; see Figure 31
Channel-to-Channel Crosstalk	-70			dB typ	$R_L = 50\ \Omega$ , $C_L = 5\text{ pF}$ , $f = 1\text{ MHz}$ ; see Figure 30
Total Harmonic Distortion + Noise, THD + N	0.08			% typ	$R_L = 1\text{ k}\Omega$ , $6\text{ V p-p}$ , $f = 20\text{ Hz}$ to $20\text{ kHz}$ ; see Figure 33

Parameter	+25°C	-40°C to +85°C	-40°C to +125°C	Unit	Test Conditions/Comments
-3 dB Bandwidth	180			MHz typ	$R_L = 50 \Omega$ , $C_L = 5 \text{ pF}$ ; see Figure 34
Insertion Loss	-1.3			dB typ	$R_L = 50 \Omega$ , $C_L = 5 \text{ pF}$ , $f = 1 \text{ MHz}$ ; see Figure 34
Off Switch Source Capacitance, $C_S$ (Off)	22			pF typ	$V_S = 6 \text{ V}$ , $f = 1 \text{ MHz}$
Off Switch Drain Capacitance, $C_D$ (Off)	22			pF typ	$V_S = 6 \text{ V}$ , $f = 1 \text{ MHz}$
On Switch Capacitance, $C_D$ (On), $C_S$ (On)	56			pF typ	$V_S = 6 \text{ V}$ , $f = 1 \text{ MHz}$
<b>POWER REQUIREMENTS</b>					
Positive Supply Current, $I_{DD}$	40		65	$\mu\text{A typ}$ $\mu\text{A max}$	$V_{DD} = 13.2 \text{ V}$ Digital inputs = 0 V or $V_L$
$I_L$	40			$\mu\text{A typ}$	All switches closed, $V_L = 5.5 \text{ V}$
	105			$\mu\text{A typ}$	All switches closed, $V_L = 2.7 \text{ V}$
Inactive	6.3		8.0	$\mu\text{A typ}$ $\mu\text{A max}$	Digital inputs = 0 V or $V_L$
Inactive, SCLK = 1 MHz	14			$\mu\text{A typ}$	$\overline{CS} = V_L$ and SDI = 0 V or $V_L$ , $V_L = 5 \text{ V}$
SCLK = 50 MHz	7			$\mu\text{A typ}$	$\overline{CS} = V_L$ and SDI = 0 V or $V_L$ , $V_L = 3 \text{ V}$
	390			$\mu\text{A typ}$	$\overline{CS} = V_L$ and SDI = 0 V or $V_L$ , $V_L = 5 \text{ V}$
Inactive, SDI = 1 MHz	210			$\mu\text{A typ}$	$\overline{CS} = V_L$ and SDI = 0 V or $V_L$ , $V_L = 3 \text{ V}$
	15			$\mu\text{A typ}$	$\overline{CS}$ and SCLK = 0 V or $V_L$ , $V_L = 5 \text{ V}$
SDI = 25 MHz	7.5			$\mu\text{A typ}$	$\overline{CS}$ and SCLK = 0 V or $V_L$ , $V_L = 3 \text{ V}$
	230			$\mu\text{A typ}$	$\overline{CS}$ and SCLK = 0 V or $V_L$ , $V_L = 5 \text{ V}$
Active at 50 MHz	120			$\mu\text{A typ}$	$\overline{CS}$ and SCLK = 0 V or $V_L$ , $V_L = 3 \text{ V}$
	1.8			mA typ	Digital inputs toggle between 0 V and $V_L$ , $V_L = 5.5 \text{ V}$
$V_{DD}$			2.1	mA max	
			0.7	mA typ	Digital inputs toggle between 0 V and $V_L$ , $V_L = 2.7 \text{ V}$
		1.0	mA max		
		9/40	V min/V max		$GND = 0 \text{ V}$ , $V_{SS} = 0 \text{ V}$

<sup>1</sup> Guaranteed by design; not subject to production test.



**36 V SINGLE SUPPLY**

$V_{DD} = 36\text{ V} \pm 10\%$ ,  $V_{SS} = 0\text{ V}$ ,  $V_L = 2.7\text{ V}$  to  $5.5\text{ V}$ ,  $GND = 0\text{ V}$ , unless otherwise noted.

**Table 4.**

Parameter	+25°C	-40°C to +85°C	-40°C to +125°C	Unit	Test Conditions/Comments
<b>ANALOG SWITCH</b>					
Analog Signal Range			0 V to $V_{DD}$	V	
On Resistance, $R_{ON}$	10.6			$\Omega$ typ	$V_S = 0\text{ V}$ to $30\text{ V}$ , $I_S = -10\text{ mA}$ ; see Figure 29
On-Resistance Match Between Channels, $\Delta R_{ON}$	12	15	17	$\Omega$ max	$V_{DD} = 32.4\text{ V}$ , $V_{SS} = 0\text{ V}$
	0.35			$\Omega$ typ	$V_S = 0\text{ V}$ to $30\text{ V}$ , $I_S = -10\text{ mA}$
On-Resistance Flatness, $R_{FLAT(ON)}$	0.7	0.9	1.1	$\Omega$ max	
	2.9			$\Omega$ typ	$V_S = 0\text{ V}$ to $30\text{ V}$ , $I_S = -10\text{ mA}$
	3.4	4	4.7	$\Omega$ max	
<b>LEAKAGE CURRENTS</b>					
Source Off Leakage, $I_S$ (Off)	$\pm 0.05$			nA typ	$V_{DD} = 39.6\text{ V}$ , $V_{SS} = 0\text{ V}$ $V_S = 1\text{ V}/30\text{ V}$ , $V_D = 30\text{ V}/1\text{ V}$ ; see Figure 32
Drain Off Leakage, $I_D$ (Off)	$\pm 0.25$	$\pm 0.75$	$\pm 6$	nA max	
	$\pm 0.05$			nA typ	$V_S = 1\text{ V}/30\text{ V}$ , $V_D = 30\text{ V}/1\text{ V}$ ; see Figure 32
Channel On Leakage, $I_D$ (On), $I_S$ (On)	$\pm 0.25$	$\pm 0.75$	$\pm 6$	nA max	
	$\pm 0.1$			nA typ	$V_S = V_D = 1\text{ V}/30\text{ V}$ ; see Figure 28
	$\pm 0.4$	$\pm 2$	$\pm 12$	nA max	
<b>DIGITAL OUTPUT</b>					
Output Voltage Low, $V_{OL}$			0.4	V max	$I_{SINK} = 5\text{ mA}$
			0.2	V max	$I_{SINK} = 1\text{ mA}$
High Impedance Leakage Current	0.001			$\mu\text{A}$ typ	$V_{OUT} = V_{GND}$ or $V_L$
High Impedance Output Capacitance			$\pm 0.1$	$\mu\text{A}$ max	
	4			pF typ	
<b>DIGITAL INPUTS</b>					
Input Voltage High, $V_{INH}$			2	V min	$3.3\text{ V} < V_L \leq 5.5\text{ V}$
			1.35	V min	$2.7\text{ V} \leq V_L \leq 3.3\text{ V}$
			0.8	V max	$3.3\text{ V} < V_L \leq 5.5\text{ V}$
			0.8	V max	$2.7\text{ V} \leq V_L \leq 3.3\text{ V}$
Input Current, $I_{INL}$ or $I_{INH}$	0.002			$\mu\text{A}$ typ	$V_{IN} = V_{GND}$ or $V_L$
			$\pm 0.1$	$\mu\text{A}$ max	
Digital Input Capacitance, $C_{IN}$	4			pF typ	

Parameter	+25°C	-40°C to +85°C	-40°C to +125°C	Unit	Test Conditions/Comments
<b>DYNAMIC CHARACTERISTICS<sup>1</sup></b>					
t <sub>ON</sub>	470			ns typ	R <sub>L</sub> = 300 Ω, C <sub>L</sub> = 35 pF
	555	565	580	ns max	V <sub>S</sub> = 18 V; see Figure 36
t <sub>OFF</sub>	195			ns typ	R <sub>L</sub> = 300 Ω, C <sub>L</sub> = 35 pF
	245	250	260	ns max	V <sub>S</sub> = 18 V; see Figure 36
Break-Before-Make Time Delay, t <sub>D</sub>	245			ns typ	R <sub>L</sub> = 300 Ω, C <sub>L</sub> = 35 pF
			185	ns min	V <sub>S1</sub> = V <sub>S2</sub> = 18 V, see Figure 35
Charge Injection, Q <sub>INJ</sub>	285			pC typ	V <sub>S</sub> = 18 V, R <sub>S</sub> = 0 Ω, C <sub>L</sub> = 1 nF; see Figure 37
Off Isolation	-78			dB typ	R <sub>L</sub> = 50 Ω, C <sub>L</sub> = 5 pF, f = 100 kHz; see Figure 31
Channel-to-Channel Crosstalk	-70			dB typ	R <sub>L</sub> = 50 Ω, C <sub>L</sub> = 5 pF, f = 1 MHz; see Figure 30
Total Harmonic Distortion + Noise, THD + N	0.03			% typ	R <sub>L</sub> = 1 kΩ, 18 V p-p, f = 20 Hz to 20 kHz; see Figure 33
-3 dB Bandwidth	174			MHz typ	R <sub>L</sub> = 50 Ω, C <sub>L</sub> = 5 pF; see Figure 34
Insertion Loss	-0.7			dB typ	R <sub>L</sub> = 50 Ω, C <sub>L</sub> = 5 pF, f = 1 MHz; see Figure 34
Off Switch Source Capacitance, C <sub>S</sub> (Off)	17			pF typ	V <sub>S</sub> = 18 V, f = 1 MHz
Off Switch Drain Capacitance, C <sub>D</sub> (Off)	17			pF typ	V <sub>S</sub> = 18 V, f = 1 MHz
On Switch Capacitance, C <sub>D</sub> (On), C <sub>S</sub> (On)	55			pF typ	V <sub>S</sub> = 18 V, f = 1 MHz
<b>POWER REQUIREMENTS</b>					
Positive Supply Current, I <sub>DD</sub>	80			μA typ	V <sub>DD</sub> = 39.6 V
	100		130	μA max	Digital inputs = 0 V or V <sub>L</sub>
	80			μA typ	All switches closed, V <sub>L</sub> = 5.5 V
	135			μA typ	All switches closed, V <sub>L</sub> = 2.7 V
I <sub>L</sub>					
Inactive	6.3			μA typ	Digital inputs = 0 V or V <sub>L</sub>
			8.0	μA max	
Inactive, SCLK = 1 MHz	14			μA typ	$\overline{CS}$ = V <sub>L</sub> and SDI = 0 V or V <sub>L</sub> , V <sub>L</sub> = 5 V
	7			μA typ	$\overline{CS}$ = V <sub>L</sub> and SDI = 0 V or V <sub>L</sub> , V <sub>L</sub> = 3 V
SCLK = 50 MHz	390			μA typ	$\overline{CS}$ = V <sub>L</sub> and SDI = 0 V or V <sub>L</sub> , V <sub>L</sub> = 5 V
	210			μA typ	$\overline{CS}$ = V <sub>L</sub> and SDI = 0 V or V <sub>L</sub> , V <sub>L</sub> = 3 V
Inactive, SDI = 1 MHz	15			μA typ	$\overline{CS}$ and SCLK = 0 V or V <sub>L</sub> , V <sub>L</sub> = 5 V
	7.5			μA typ	$\overline{CS}$ and SCLK = 0 V or V <sub>L</sub> , V <sub>L</sub> = 3 V
SDI = 25 MHz	230			μA typ	$\overline{CS}$ and SCLK = 0 V or V <sub>L</sub> , V <sub>L</sub> = 5 V
	120			μA typ	$\overline{CS}$ and SCLK = 0 V or V <sub>L</sub> , V <sub>L</sub> = 3 V
Active at 50 MHz	1.8			mA typ	Digital inputs toggle between 0 V and V <sub>L</sub> , V <sub>L</sub> = 5.5 V
			2.1	mA max	
	0.7			mA typ	Digital inputs toggle between 0 V and V <sub>L</sub> , V <sub>L</sub> = 2.7 V
			1.0	mA max	
V <sub>DD</sub>			9/40	V min/V max	GND = 0 V, V <sub>SS</sub> = 0 V

<sup>1</sup> Guaranteed by design; not subject to production test.

**CONTINUOUS CURRENT PER CHANNEL, S<sub>x</sub> OR D<sub>x</sub>****Table 5. Four Channels On**

Parameter	25°C	85°C	125°C	Unit
CONTINUOUS CURRENT, S <sub>x</sub> OR D <sub>x</sub> V <sub>DD</sub> = +15 V, V <sub>SS</sub> = -15 V LFCSP (θ <sub>JA</sub> = 50°C/W)	126	94	59	mA max
V <sub>DD</sub> = +20 V, V <sub>SS</sub> = -20 V LFCSP (θ <sub>JA</sub> = 50°C/W)	133	98	63	mA max
V <sub>DD</sub> = 12 V, V <sub>SS</sub> = 0 V LFCSP (θ <sub>JA</sub> = 50°C/W)	97	71	44	mA max
V <sub>DD</sub> = 36 V, V <sub>SS</sub> = 0 V LFCSP (θ <sub>JA</sub> = 50°C/W)	131	97	62	mA max

**Table 6. One Channel On**

Parameter	25°C	85°C	125°C	Unit
CONTINUOUS CURRENT, S <sub>x</sub> OR D <sub>x</sub> V <sub>DD</sub> = +15 V, V <sub>SS</sub> = -15 V LFCSP (θ <sub>JA</sub> = 50°C/W)	230	154	102	mA max
V <sub>DD</sub> = +20 V, V <sub>SS</sub> = -20 V LFCSP (θ <sub>JA</sub> = 50°C/W)	241	160	104	mA max
V <sub>DD</sub> = 12 V, V <sub>SS</sub> = 0 V LFCSP (θ <sub>JA</sub> = 50°C/W)	180	126	88	mA max
V <sub>DD</sub> = 36 V, V <sub>SS</sub> = 0 V LFCSP (θ <sub>JA</sub> = 50°C/W)	239	158	104	mA max

**TIMING CHARACTERISTICS**

V<sub>L</sub> = 2.7 V to 5.5 V; GND = 0 V; all specifications T<sub>MIN</sub> to T<sub>MAX</sub>, unless otherwise noted. Guaranteed by design and characterization, not production tested.

**Table 7.**

Parameter	Limit at T <sub>MIN</sub> , T <sub>MAX</sub>	Unit	Test Conditions/Comments
t <sub>1</sub>	20	ns min	SCLK period
t <sub>2</sub>	8	ns min	SCLK high pulse width
t <sub>3</sub>	8	ns min	SCLK low pulse width
t <sub>4</sub>	10	ns min	$\overline{CS}$ falling edge to SCLK rising edge
t <sub>5</sub>	6	ns min	Data setup time
t <sub>6</sub>	8	ns min	Data hold time
t <sub>7</sub>	10	ns min	SCLK rising edge to $\overline{CS}$ rising edge
t <sub>8</sub>	20	ns max	$\overline{CS}$ falling edge to SDO data available
t <sub>9</sub> <sup>1</sup>	20	ns max	SCLK falling edge to SDO data available
t <sub>10</sub>	20	ns max	$\overline{CS}$ rising edge to SDO returns to high impedance
t <sub>11</sub>	20	ns min	$\overline{CS}$ high time between SPI commands
t <sub>12</sub>	8	ns min	$\overline{CS}$ falling edge to SCLK becomes stable
t <sub>13</sub>	8	ns min	$\overline{CS}$ rising edge to SCLK becomes stable

<sup>1</sup> Measured with the 1 kΩ pull-up resistor to V<sub>L</sub> and 20 pF load. The parameter t<sub>9</sub> determines the maximum SCLK frequency when SDO is used.

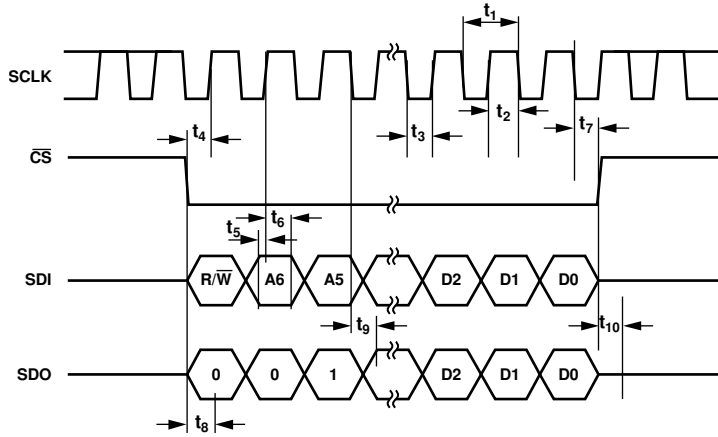

Figure 2. Addressable Mode Timing Diagram

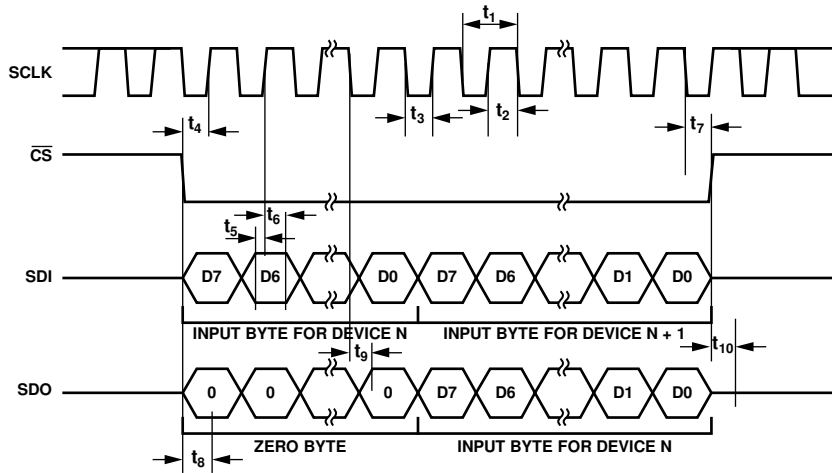

Figure 3. Daisy Chain Timing Diagram

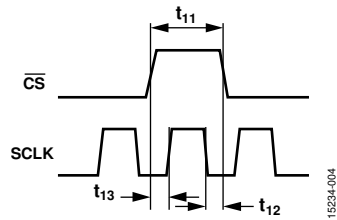

Figure 4. SCLK/ $\overline{CS}$  Timing Relationship

## ABSOLUTE MAXIMUM RATINGS

$T_A = 25^\circ\text{C}$ , unless otherwise noted.

**Table 8.**

Parameter	Rating
$V_{DD}$ to $V_{SS}$	48 V
$V_{DD}$ to GND	-0.3 V to +48 V
$V_{SS}$ to GND	+0.3 V to -48 V
$V_L$ to GND	-0.3 V to +6 V
Analog Inputs <sup>1</sup>	$V_{SS} - 0.3\text{ V}$ to $V_{DD} + 0.3\text{ V}$ or 30 mA, whichever occurs first
Digital Inputs <sup>1</sup>	-0.3 V to +6 V
Peak Current, $S_X$ or $D_X$	261 mA (pulsed at 1 ms, 10% duty cycle maximum)
Continuous Current, $S_X$ or $D_X$ <sup>2</sup>	Data + 15%
Temperature Ranges	
Operating	-40°C to +125°C
Storage	-65°C to +150°C
Junction Temperature	150°C
Thermal Impedance, $\theta_{JA}$	50°C/W
Reflow Soldering Peak Temperature, Pb Free	260 (+0/-5)°C
Human Body Model (HBM) ESD Rating	8 kV

<sup>1</sup> Overvoltages at the  $S_X$  pins and  $D_X$  pins are clamped by internal diodes. Limit the current to the maximum ratings given.

<sup>2</sup> See Table 5.

Stresses at or above those listed under Absolute Maximum Ratings may cause permanent damage to the product. This is a stress rating only; functional operation of the product at these or any other conditions above those indicated in the operational section of this specification is not implied. Operation beyond the maximum operating conditions for extended periods may affect product reliability.

Only one absolute maximum rating can be applied at any one time.

### ESD CAUTION



**ESD (electrostatic discharge) sensitive device.** Charged devices and circuit boards can discharge without detection. Although this product features patented or proprietary protection circuitry, damage may occur on devices subjected to high energy ESD. Therefore, proper ESD precautions should be taken to avoid performance degradation or loss of functionality.

## PIN CONFIGURATIONS AND FUNCTION DESCRIPTIONS

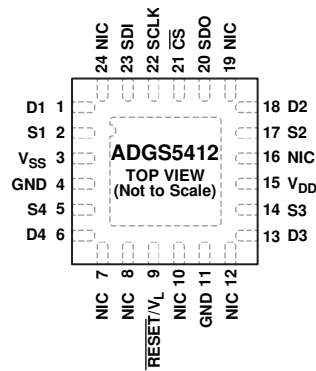

- NOTES
1. THE EXPOSED PAD IS CONNECTED INTERNALLY. FOR INCREASED RELIABILITY OF THE SOLDER JOINTS AND MAXIMUM THERMAL CAPABILITY, IT IS RECOMMENDED THAT THE EXPOSED PAD BE SOLDERED TO THE SUBSTRATE,  $V_{SS}$ .
  2. NIC = NOT INTERNALLY CONNECTED.

15824-005

Figure 5. Pin Configuration

Table 9. Pin Function Descriptions

Pin No.	Mnemonic	Description
1	D1	Drain Terminal 1. This pin can be an input or an output.
2	S1	Source Terminal 1. This pin can be an input or an output.
3	$V_{SS}$	Most Negative Power Supply Potential. In single-supply applications, tie this pin to GND.
4, 11	GND	Ground (0 V) Reference.
5	S4	Source Terminal 4. This pin can be an input or an output.
6	D4	Drain Terminal 4. This pin can be an input or an output.
7, 8, 10, 12, 16, 19, 24	NIC	Not Internally Connected.
9	$\overline{\text{RESET}}/V_L$	$\overline{\text{RESET}}/V_L$ / Logic Power Supply Input ( $V_L$ ). Under normal operation, drive the $\overline{\text{RESET}}/V_L$ pin with a 2.7 V to 5.5 V supply. Pull the pin low to complete a hardware reset. All switches are opened, and the appropriate registers are set to their default values.
13	D3	Drain Terminal 3. This pin can be an input or an output.
14	S3	Source Terminal 3. This pin can be an input or an output.
15	$V_{DD}$	Most Positive Power Supply Potential.
17	S2	Source Terminal 2. This pin can be an input or an output.
18	D2	Drain Terminal 2. This pin can be an input or an output.
20	SDO	Serial Data Output. This pin can be used for daisy-chaining a number of these devices together or for reading back the data stored in a register for diagnostic purposes. The serial data is propagated on the falling edge of SCLK. Pull this open-drain output to $V_L$ with an external resistor.
21	$\overline{\text{CS}}$	Active Low Control Input. This is the frame synchronization signal for the input data. When $\overline{\text{CS}}$ goes low, it powers on the SCLK buffers and enables the input shift register. Data is transferred in on the falling edges of the following clocks. Taking $\overline{\text{CS}}$ high updates the switch condition.
22	SCLK	Serial Clock Input. Data is captured on the positive edge of SCLK. Data can be transferred at rates of up to 50 MHz.
23	SDI	Serial Data Input. Data is captured on the positive edge of the serial clock input.
	EPAD	Exposed Pad. The exposed pad is connected internally. For increased reliability of the solder joints and maximum thermal capability, it is recommended that the pad be soldered to the substrate, $V_{SS}$ .

### TYPICAL PERFORMANCE CHARACTERISTICS

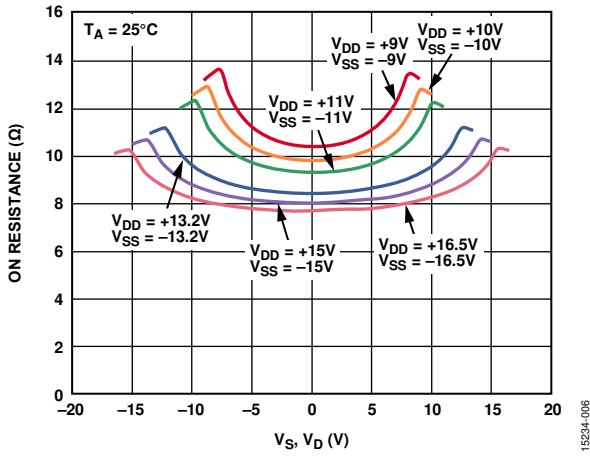

Figure 6. On Resistance ( $R_{ON}$ ) as a Function of  $V_S$ ,  $V_D$  (Dual Supply)

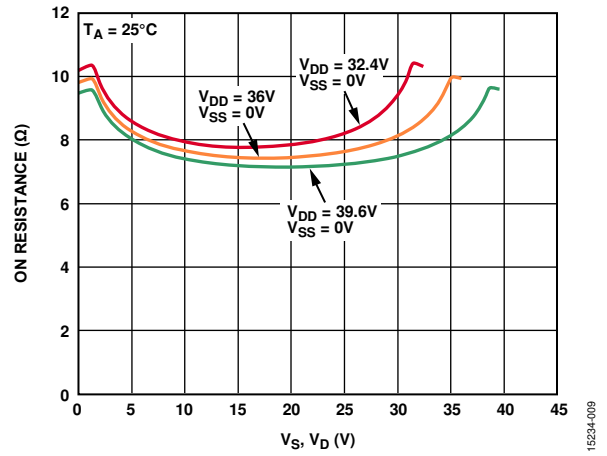

Figure 9. On Resistance ( $R_{ON}$ ) as a Function of  $V_S$ ,  $V_D$  (Single Supply)

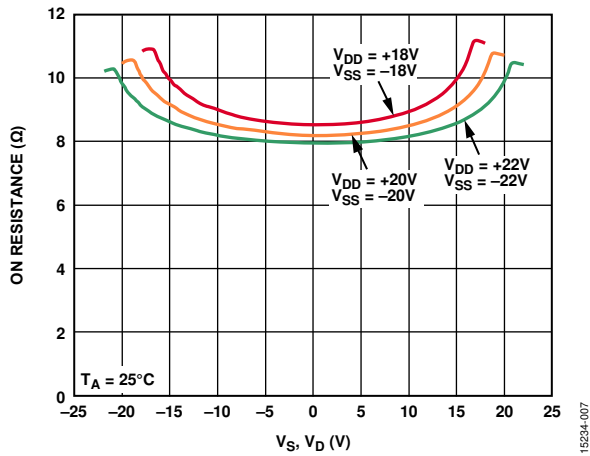

Figure 7. On Resistance ( $R_{ON}$ ) as a Function of  $V_S$ ,  $V_D$  (Dual Supply)

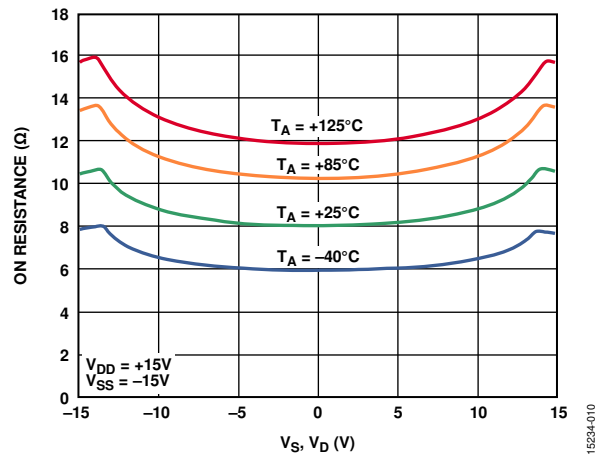

Figure 10. On Resistance ( $R_{ON}$ ) as a Function of  $V_S$ ,  $V_D$  for Various Temperatures,  $\pm 15V$  Dual Supply

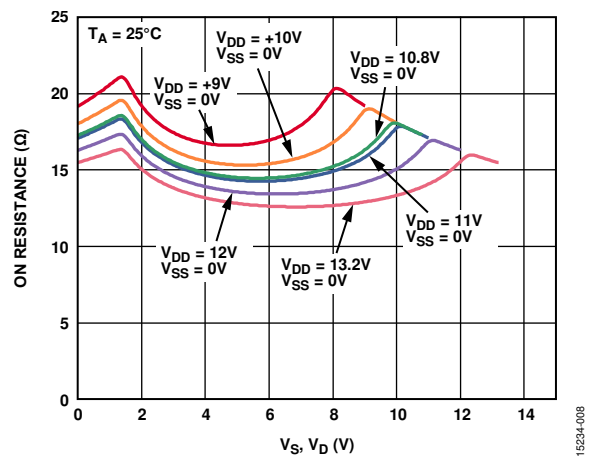

Figure 8. On Resistance ( $R_{ON}$ ) as a Function of  $V_S$ ,  $V_D$  (Single Supply)

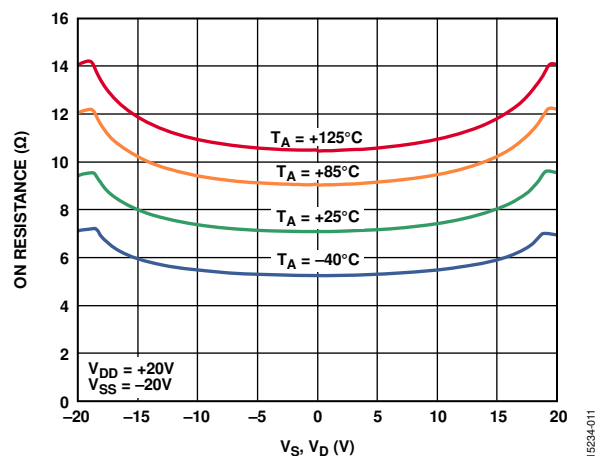

Figure 11. On Resistance ( $R_{ON}$ ) as a Function of  $V_S$ ,  $V_D$  for Various Temperatures,  $\pm 20V$  Dual Supply

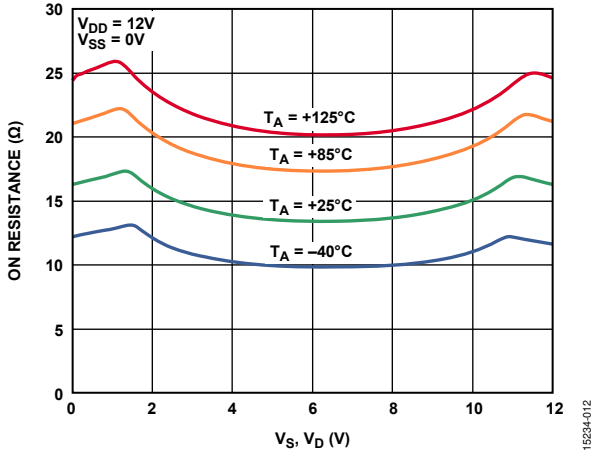

Figure 12. On Resistance ( $R_{ON}$ ) as a Function of  $V_S, V_D$  for Various Temperatures, 12 V Single Supply

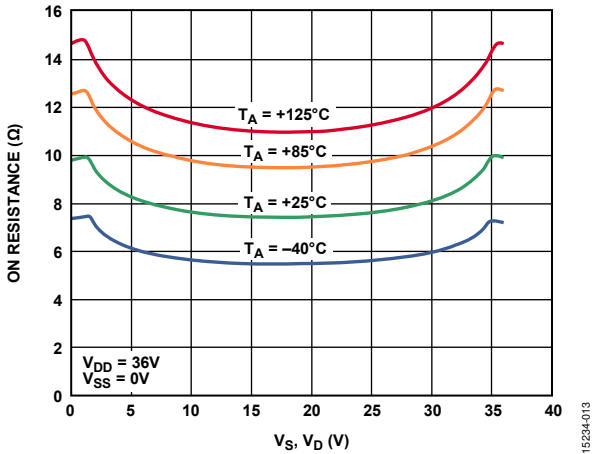

Figure 13.  $R_{ON}$  as a Function of  $V_S, V_D$  for Various Temperatures, 36 V Single Supply

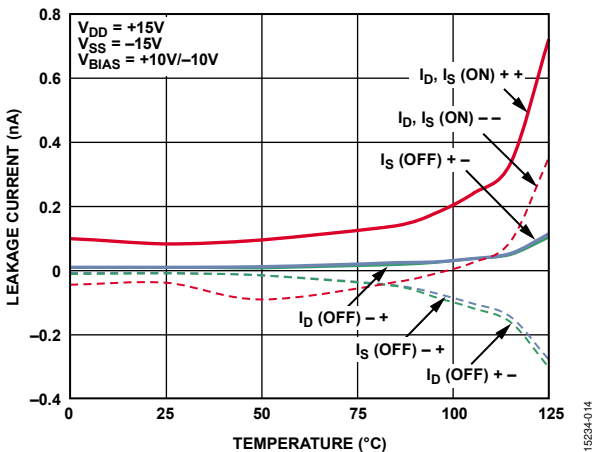

Figure 14. Leakage Currents vs. Temperature,  $\pm 15$  V Dual Supply

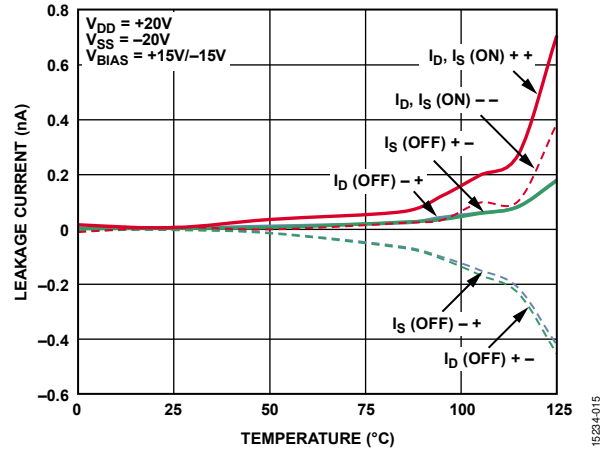

Figure 15. Leakage Currents vs. Temperature,  $\pm 20$  V Dual Supply

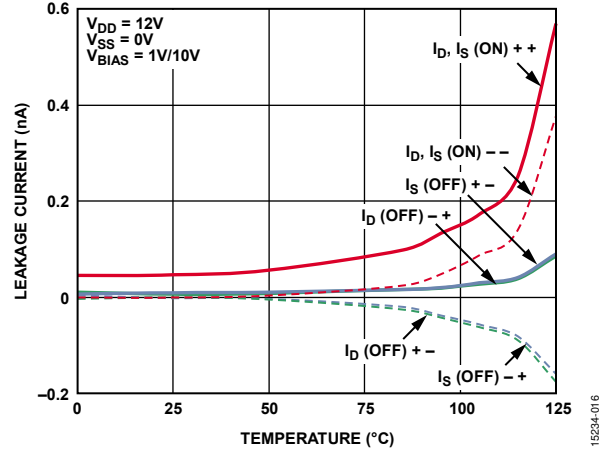

Figure 16. Leakage Currents vs. Temperature, 12 V Single Supply

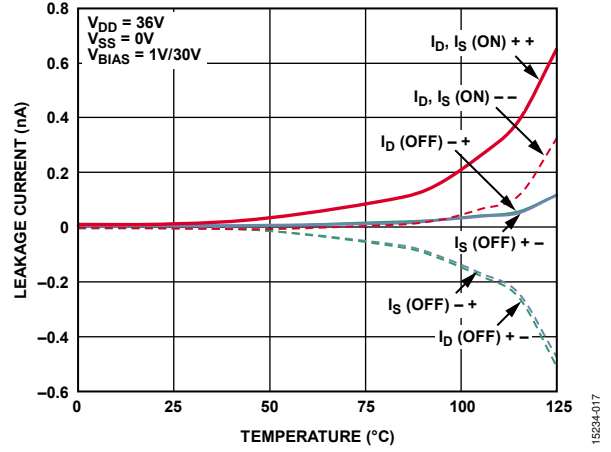

Figure 17. Leakage Currents vs. Temperature, 36 V Single Supply



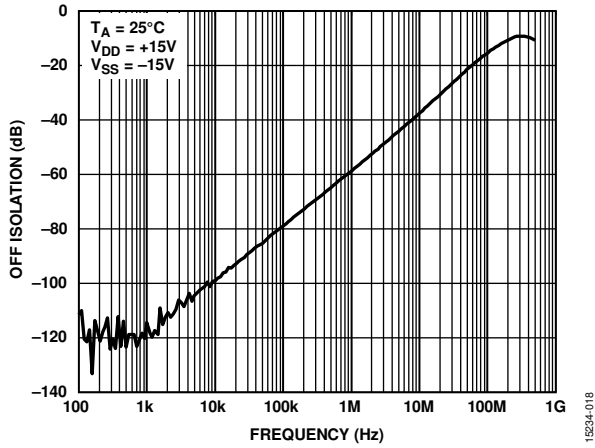

Figure 18. Off Isolation vs. Frequency, ±15 V Dual Supply

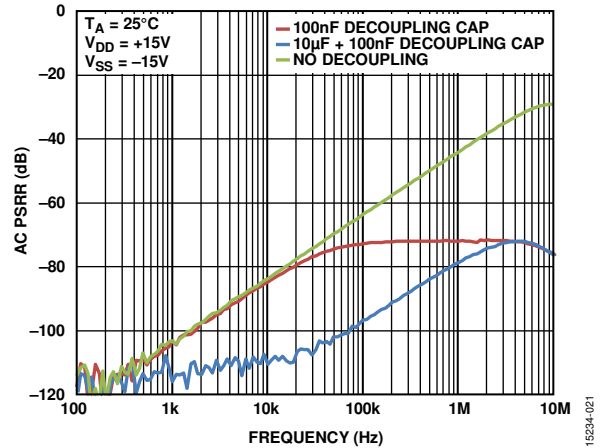

Figure 21. AC Power Supply Rejection Ratio (PSRR) vs. Frequency, ±15 V Dual Supply

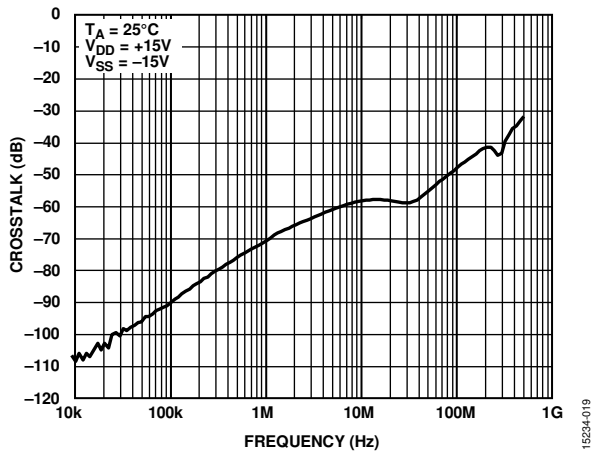

Figure 19. Crosstalk vs. Frequency, ±15 V Dual Supply

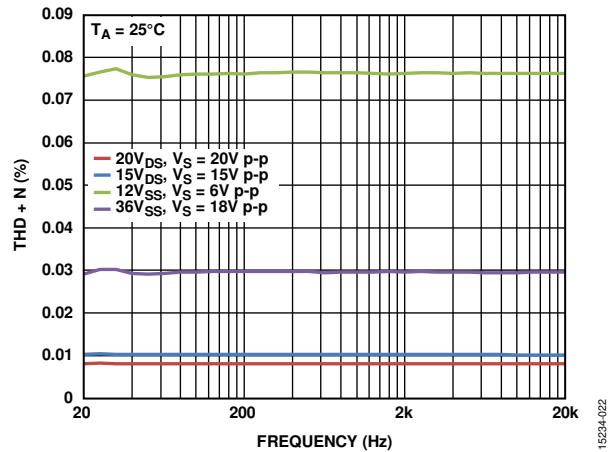

Figure 22. THD + N vs. Frequency, ±15 V Dual Supply

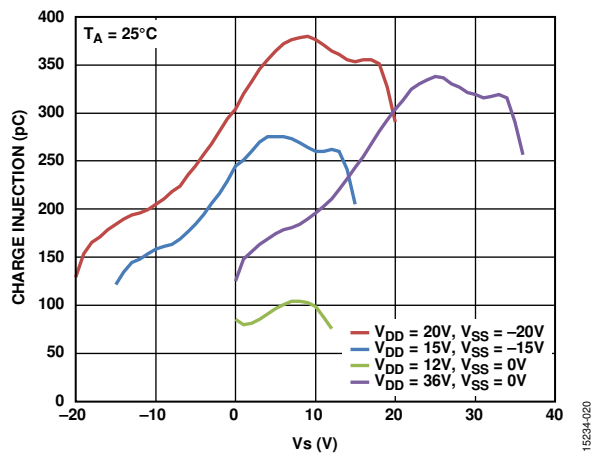

Figure 20. Charge Injection vs. Source Voltage,  $V_s$

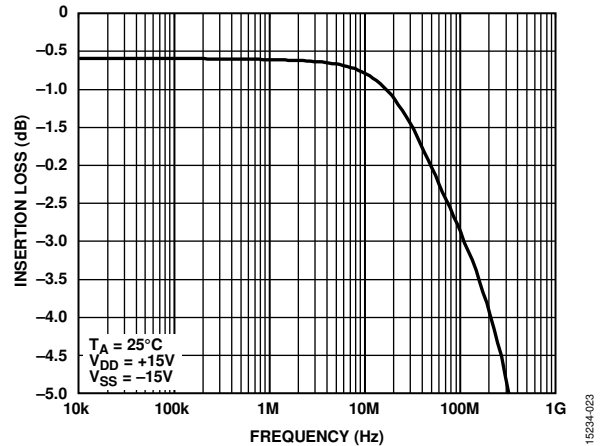

Figure 23. Bandwidth

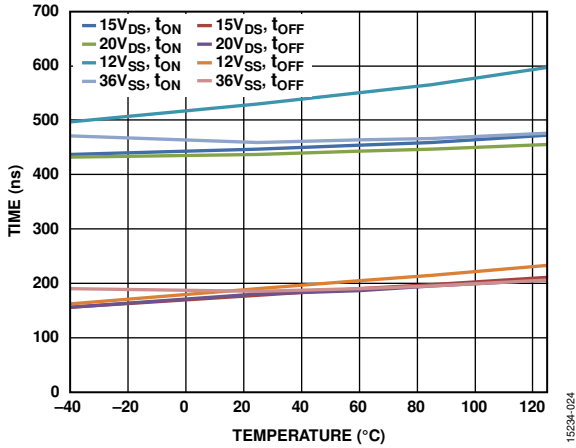

Figure 24.  $t_{ON}$ ,  $t_{OFF}$  Times vs. Temperature

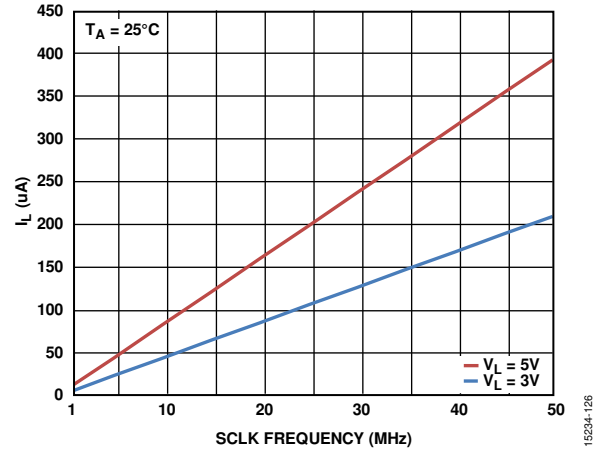

Figure 26.  $I_L$  vs. SCLK Frequency When  $\overline{CS}$  Is High

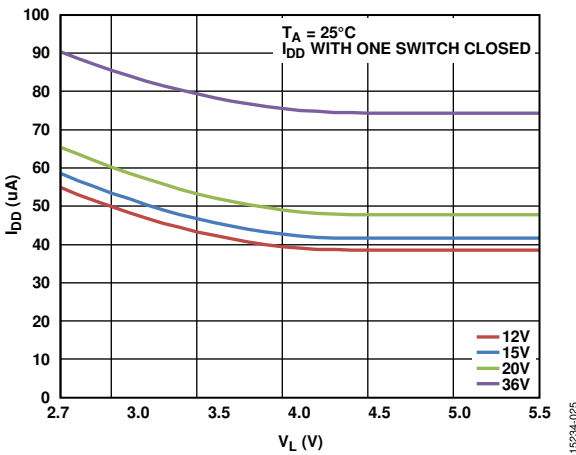

Figure 25.  $I_{DD}$  vs.  $V_L$

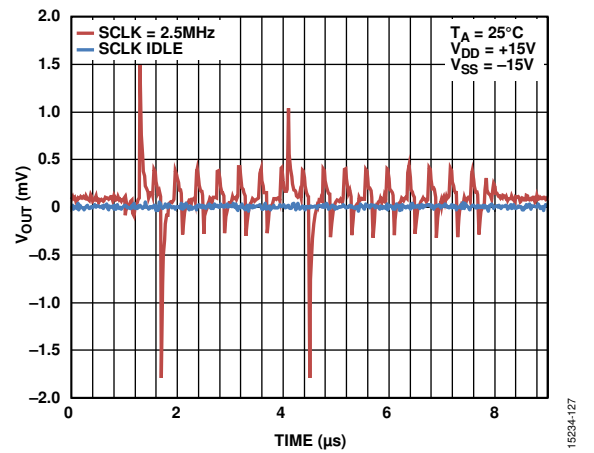

Figure 27. Digital Feedthrough

TEST CIRCUITS

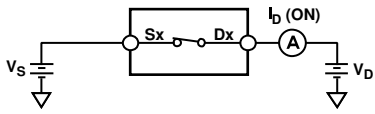

Figure 28. On Leakage

15234-026

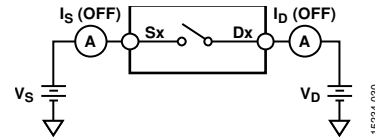

Figure 32. Off Leakage

15234-030

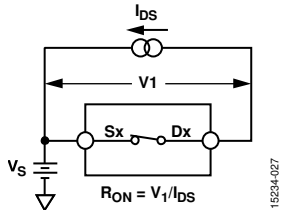
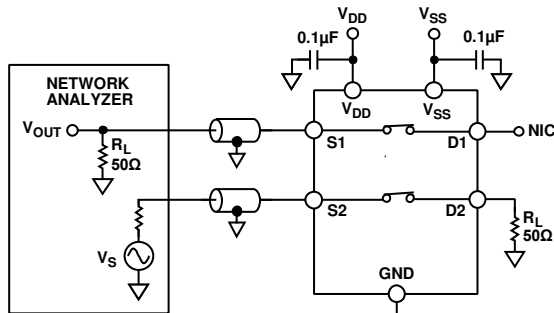

Figure 29. On Resistance

15234-027



$$\text{CHANNEL TO CHANNEL CROSSTALK} = 20 \log \frac{V_{OUT}}{V_S}$$

Figure 30. Channel to Channel Crosstalk

15234-028

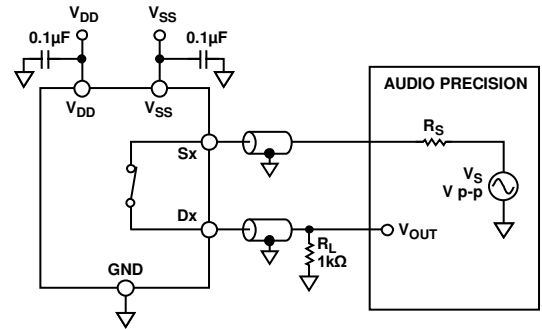
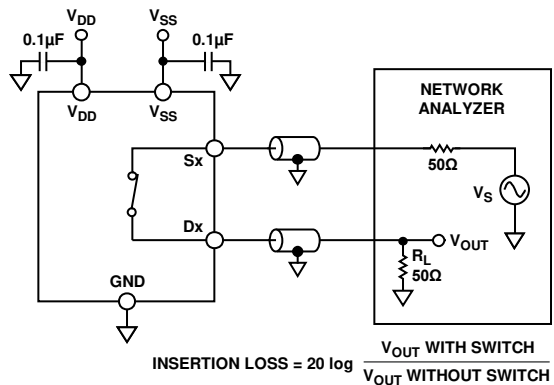

Figure 33. THD + N

15234-031



$$\text{INSERTION LOSS} = 20 \log \frac{V_{OUT \text{ WITH SWITCH}}}{V_{OUT \text{ WITHOUT SWITCH}}}$$

Figure 34. Bandwidth

15234-032

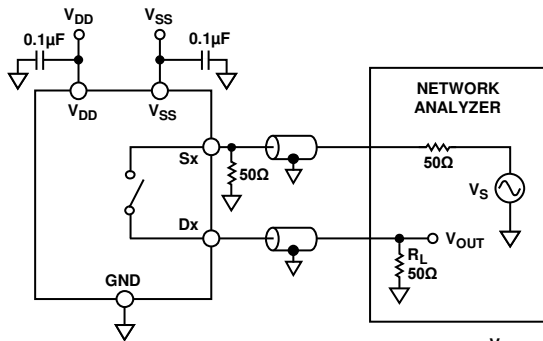

$$\text{OFF ISOLATION} = 20 \log \frac{V_{OUT}}{V_S}$$

Figure 31. Off Isolation

15234-029

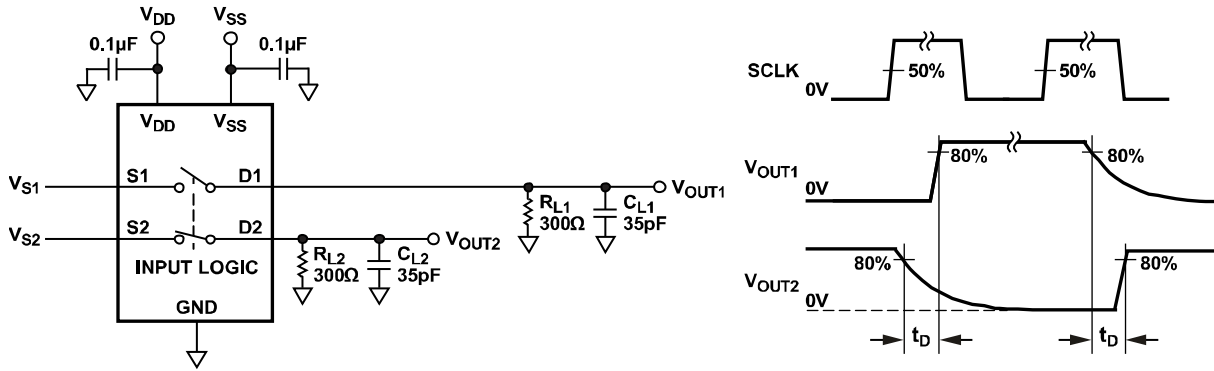

Figure 35. Break-Before-Make Time Delay,  $t_D$

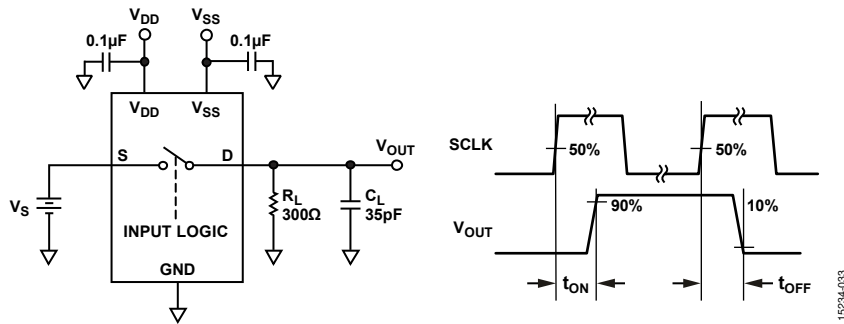

Figure 36. Switching Times

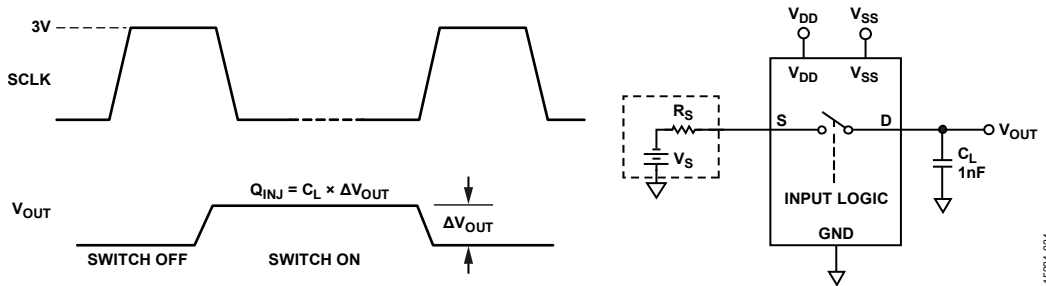
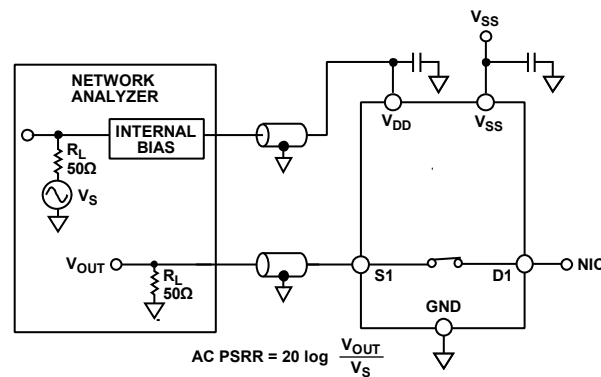

Figure 37. Charge Injection



NOTES  
1. BOARD AND COMPONENT EFFECTS ARE NOT DE-EMBEDDED FROM THE AC PSRR MEASUREMENT.

Figure 38. AC PSRR

## TERMINOLOGY

### $I_{DD}$

$I_{DD}$  is the positive supply current.

### $I_{SS}$

$I_{SS}$  is the negative supply current.

### $V_D, V_S$

$V_D$  and  $V_S$  are the analog voltages on Terminal D and Terminal S, respectively.

### $R_{ON}$

$R_{ON}$  is the ohmic resistance between Terminal D and Terminal S.

### $\Delta R_{ON}$

$\Delta R_{ON}$  is the difference between the  $R_{ON}$  of any two channels.

### $R_{FLAT(ON)}$

$R_{FLAT(ON)}$  is flatness that is defined as the difference between the maximum and minimum value of on resistance measured over the specified analog signal range.

### $I_S$ (Off)

$I_S$  (Off) is the source leakage current with the switch off.

### $I_D$ (Off)

$I_D$  (Off) is the drain leakage current with the switch off.

### $I_D$ (On), $I_S$ (On)

$I_D$  (On) and  $I_S$  (On) are the channel leakage currents with the switch on.

### $V_{INL}$

$V_{INL}$  is the maximum input voltage for Logic 0.

### $V_{INH}$

$V_{INH}$  is the minimum input voltage for Logic 1.

### $I_{INL}, I_{INH}$

$I_{INL}$  and  $I_{INH}$  are the low and high input currents of the digital inputs.

### $C_D$ (Off)

$C_D$  (Off) is the off switch drain capacitance, which is measured with reference to the GND pin.

### $C_S$ (Off)

$C_S$  (Off) is the off switch source capacitance, which is measured with reference to the GND pin.

### $C_D$ (On), $C_S$ (On)

$C_D$  (On) and  $C_S$  (On) are the on switch capacitances, which are measured with reference to the GND pin

### $C_{IN}$

$C_{IN}$  is the digital input capacitance.

### $t_{ON}$

$t_{ON}$  is the delay between applying the digital control input and the output switching on.

### $t_{OFF}$

$t_{OFF}$  is the delay between applying the digital control input and the output switching off.

### $t_D$

$t_D$  is the off time measured between the 80% point of both switches when switching from one address state to another.

### Off Isolation

Off isolation is a measure of unwanted signal coupling through an off switch.

### Charge Injection

Charge injection is a measure of the glitch impulse transferred from the digital input to the analog output during switching.

### Crosstalk

Crosstalk is a measure of unwanted signal that is coupled through from one channel to another as a result of parasitic capacitance.

### Bandwidth

Bandwidth is the frequency at which the output is attenuated by 3 dB.

### On Response

On response is the frequency response of the on switch.

### Insertion Loss

Insertion loss is the loss due to the on resistance of the switch.

### Total Harmonic Distortion + Noise (THD + N)

THD + N is the ratio of the harmonic amplitude plus the noise of the signal to the fundamental.

### AC Power Supply Rejection Ratio (AC PSRR)

AC PSRR is the ratio of the amplitude of signal on the output to the amplitude of the modulation. This is a measure of the ability of the device to avoid coupling noise and spurious signals that appear on the supply voltage pin to the output of the switch. The dc voltage on the device is modulated by a sine wave of 0.62 V p-p.

## THEORY OF OPERATION

The ADGS5412 is a set of serially controlled, quad SPST switches with error detection features. SPI Mode 0 and Mode 3 can be used with the device, and it operates with SCLK frequencies up to 50 MHz. The default mode for the ADGS5412 is address mode, in which the registers of the device are accessed by a 16-bit SPI command that is bounded by  $\overline{CS}$ . The SPI command becomes 24-bit if the user enables CRC error detection. Other error detection features include SCLK count error and invalid read/write error. If any of these SPI interface errors occur, they are detectable by reading the error flags register. The ADGS5412 can also operate in two other modes: burst mode and daisy-chain mode.

The interface pins of the ADGS5412 are  $\overline{CS}$ , SCLK, SDI, and SDO. Hold  $\overline{CS}$  low when using the SPI interface. Data is captured on the SDI pin on the rising edge of SCLK, and data is propagated out on the SDO pin on the falling edge of SCLK. SDO has an open-drain output; thus, connect a pull-up to this output. When not pulled low by the ADGS5412, SDO is in a high impedance state.

### ADDRESS MODE

Address mode is the default mode for the ADGS5412 on power-up. A single SPI frame in address mode is bounded by a  $\overline{CS}$  falling edge and the succeeding  $\overline{CS}$  rising edge. It is comprised of 16 SCLK cycles. The timing diagram for address mode is shown in Figure 39. The first SDI bit indicates if the SPI command is a read or write command. When the first bit is set to 0, a write command is issued, and if the first bit is set to 1, a read command is issued. The next seven bits determine the target register address. The remaining eight bits provide the data to the addressed register. The last eight bits are ignored during a read command, because during these clock cycles, SDO propagates out the data contained in the addressed register.

The target register address of an SPI command is determined on the eighth SCLK rising edge. Data from this register propagates out on SDO from the ninth to the 16<sup>th</sup> SCLK falling edge during SPI

reads. A register write occurs on the 16<sup>th</sup> SCLK rising edge during SPI writes.

During any SPI command, SDO sends out eight alignment bits on the first eight SCLK falling edges. The alignment bits observed at SDO are 0x25.

### ERROR DETECTION FEATURES

Protocol and communication errors on the SPI interface are detectable. There are three detectable errors, which are incorrect SCLK error detection, invalid read and write address error detection, and CRC error detection. Each of these errors has a corresponding enable bit in the error configuration register. In addition, there is an error flag bit for each of these errors in the error flags register.

#### Cyclic Redundancy Check (CRC) Error Detection

The CRC error detection feature extends a valid SPI frame by eight SCLK cycles. These eight extra cycles are needed to send the CRC byte for that SPI frame. The CRC byte is calculated by the SPI block using the 16-bit payload: the R/W bit, Register Address Bits[6:0], and Register Data Bits[7:0]. The CRC polynomial used in the SPI block is  $x^8 + x^2 + x^1 + 1$  with a seed value of 0. For a timing diagram with CRC enabled, see Figure 40. Register writes occur at the 24<sup>th</sup> SCLK rising edge with CRC error checking enabled.

During an SPI write, the microcontroller or CPU provides the CRC byte through SDI. The SPI block checks the CRC byte just before the 24<sup>th</sup> SCLK rising edge. On this same edge, the register write is prevented if an incorrect CRC byte is received by the SPI interface. The CRC error flag is asserted in the error flags register in the case of the incorrect CRC byte being detected.

During an SPI read, the CRC byte is provided to the microcontroller through SDO.

The CRC error detection feature is disabled by default and can be configured by the user through the error configuration register.

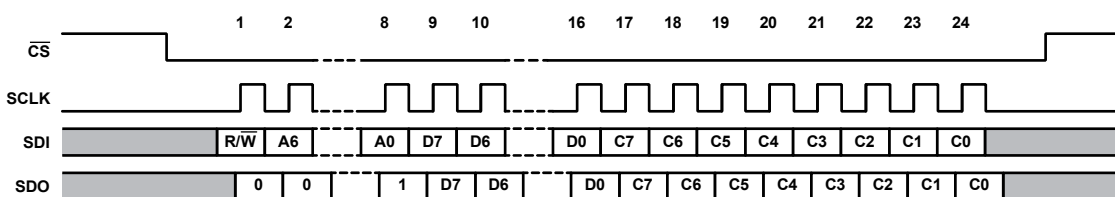
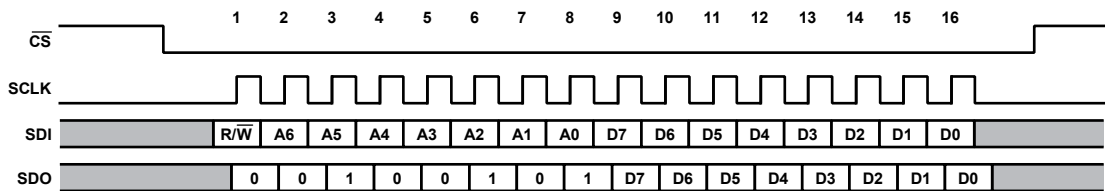

**SCLK Count Error Detection**

SCLK count error detection allows the user to detect if an incorrect number of SCLK cycles are sent by the microcontroller or CPU. When in address mode, with CRC disabled, 16 SCLK cycles are expected. If 16 SCLK cycles are not detected, the SCLK count error flag asserts in the error flags register. When less than 16 SCLK cycles are received by the device, a write to the register map never occurs. When the ADGS5412 receives more than 16 SCLK cycles, a write to the memory map still occurs at the 16<sup>th</sup> SCLK rising edge, and the flag asserts in the error flags register. With CRC enabled, the expected number of SCLK cycles becomes 24. SCLK count error detection is enabled by default and can be configured by the user through the error configuration register.

**Invalid Read/Write Address Error**

An invalid read/write address error detects when a nonexistent register address is a target for a read or write. In addition, this error asserts when a write to a read only register is attempted. The invalid read/write address error flag asserts in the error flags register when an invalid read/write address error occurs. The invalid read/write address error is detected on the ninth SCLK rising edge, which means a write to the register never occurs when an invalid address is targeted. Invalid read/write address error detection is enabled by default and can be disabled by the user through the error configuration register.

**CLEARING THE ERROR FLAGS REGISTER**

To clear the error flags register, write the special 16-bit SPI frame, 0x6CA9, to the device. This SPI command does not trigger the invalid R/W address error. When CRC is enabled, the user must also send the correct CRC byte for a successful error clear command. At the 16<sup>th</sup> or 24<sup>th</sup> SCLK rising edge, the error flags register resets to zero.

**BURST MODE**

The SPI interface can accept consecutive SPI commands without the need to deassert the CS line, which is called burst mode. Burst mode is enabled through the burst enable register. This mode uses the same 16-bit command to communicate with the device. In addition, the response of the device at SDO is still aligned with the corresponding SPI command. Figure 41 shows an example of SDI and SDO during burst mode.

The invalid read/write address and CRC error checking functions operate similarly during burst mode as they do during address mode. However, SCLK count error detection operates in a slightly different manner. The total number of SCLK cycles within a given CS frame are counted, and if the total is not a multiple of 16 or a multiple of 24 when CRC is enabled, the SCLK count error flag asserts.

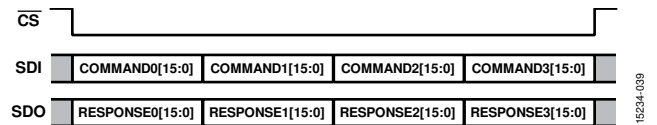

Figure 41. Burst Mode Frame

**SOFTWARE RESET**

When in address mode, the user can initiate a software reset. To do so, write two consecutive SPI commands, namely 0xA3 followed by 0x05, targeting Register 0x0B. After a software reset, all register values are set to default.

**DAISY-CHAIN MODE**

The connection of several ADGS5412 devices in a daisy-chain configuration is possible, and Figure 42 shows this setup. All devices share the same CS and SCLK line, whereas the SDO of a device forms a connection to the SDI of the next device, creating a shift register. In daisy-chain mode, SDO is an eight cycle delayed version of SDI. When in daisy-chain mode, all commands target the switch data register. Therefore, it is not possible to make configuration changes while in daisy-chain mode.

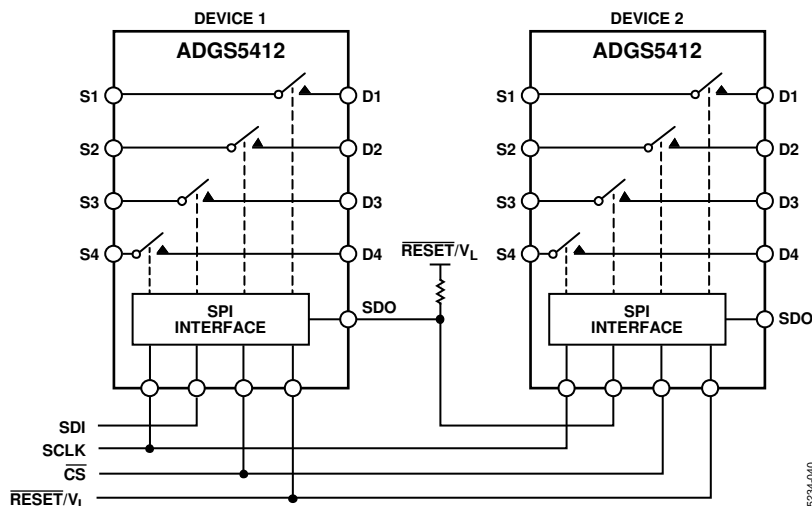

Figure 42. Two SPI Controlled Switches Connected in a Daisy-Chain Configuration

The ADGS5412 can only enter daisy-chain mode when in address mode by sending the 16-bit SPI command, 0x2500 (see Figure 43). When the ADGS5412 receives this command, the SDO of the device sends out the same command because the alignment bits at SDO are 0x25, which allows multiple daisy-connected devices to enter daisy-chain mode in a single SPI frame. A hardware reset is required to exit daisy-chain mode.

For the timing diagram of a typical daisy-chain SPI frame, see Figure 44. When  $\overline{CS}$  goes high, Device 1 writes Command 0, Bits[7:0] to its switch data register, Device 2 writes Command 1, Bits[7:0] to its switches, and so on. The SPI block uses the last eight bits it received through SDI to update the switches. After entering daisy-chain mode, the first eight bits sent out by SDO on each device in the chain are 0x00. When  $\overline{CS}$  goes high, the internal shift register value does not reset back to zero.

An SCLK rising edge reads in data on SDI while data is propagated out SDO on an SCLK falling edge. The expected number of SCLK cycles must be a multiple of eight before  $\overline{CS}$  goes high. When this is not the case, the SPI interface sends the last eight bits received to the switch data register

**POWER-ON RESET**

The digital section of the ADGS5412 goes through an initialization phase during  $V_L$  power up. This initialization also occurs after a hardware or software reset. After  $V_L$  power-up or a reset, ensure that a minimum of 120  $\mu s$  from the time of power-up or reset before any SPI command is issued. Ensure that  $V_L$  does not drop out during the 120  $\mu s$  initialization phase because it may result in incorrect operation of the ADGS5412.

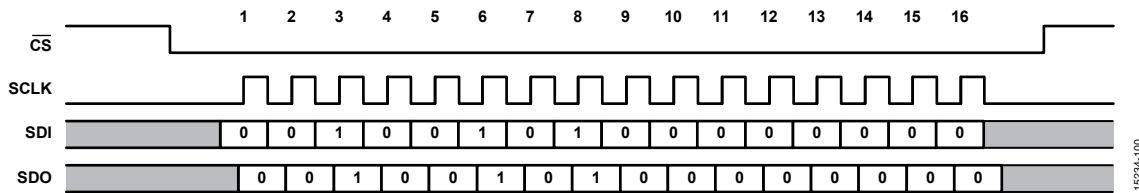

Figure 43. SPI Command to Enter Daisy-Chain Mode

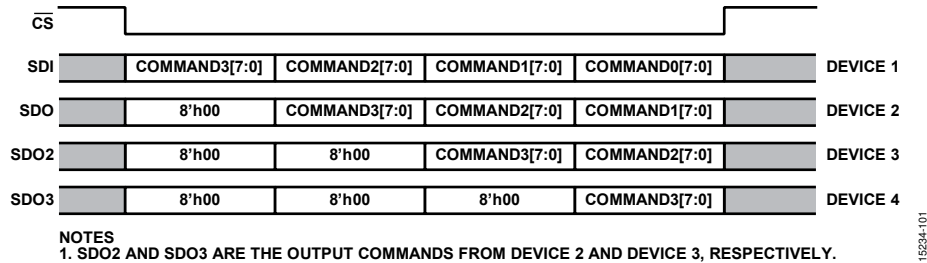

Figure 44. Example of an SPI Frame When Four ADGS5412 Devices are Connected in Daisy-Chain Mode



## BREAK-BEFORE-MAKE SWITCHING

The ADGS5412 exhibits break-before-make switching action, which allows the use of the device in multiplexer applications. This configuration can be achieved by externally hardwiring the device in the mux configuration that is required, as shown in Figure 45.

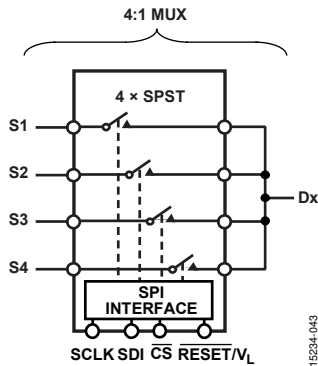

Figure 45. An SPI Controlled Switch Configured into a 4:1 Mux

## TRENCH ISOLATION

In the analog switch section of the ADGS5412, an insulating oxide layer (trench) is placed between the negative channel metal-oxide semiconductor (NMOS) and the positive channel metal-oxide semiconductor (PMOS) transistors of each complementary metal oxide semiconductor switch (CMOS). Parasitic junctions, which occur between the transistors in junction isolated switches, are eliminated, and the result is a completely latch-up proof switch.

In junction isolation, the negative (N) and positive (P) wells of the PMOS and NMOS transistors form a diode that is reverse-biased under normal operation. However, during overvoltage conditions, this diode can become forward-biased. A silicon controlled rectifier (SCR) circuit is formed by the two transistors, causing a significant amplification of the current that, in turn, leads to latch-up. With trench isolation, this diode is removed, and the result is a latch-up proof switch. The ADGS5412 analog

switch pins pass the maximum rating in the JESD78D standard in which they are stressed with a  $\pm 500$  mA pulse for 1 second.

The high voltage latch-up proof family of switches and multiplexers provide a robust solution for instrumentation, industrial, automotive, aerospace, and other harsh environments that are prone to latch-up, which is an undesirable high current state that can lead to device failure and which persists until the power supply is turned off. The ADGS5412 high voltage switches allow single-supply operation from 9 V to 40 V and dual-supply operation from  $\pm 9$  V to  $\pm 22$  V.

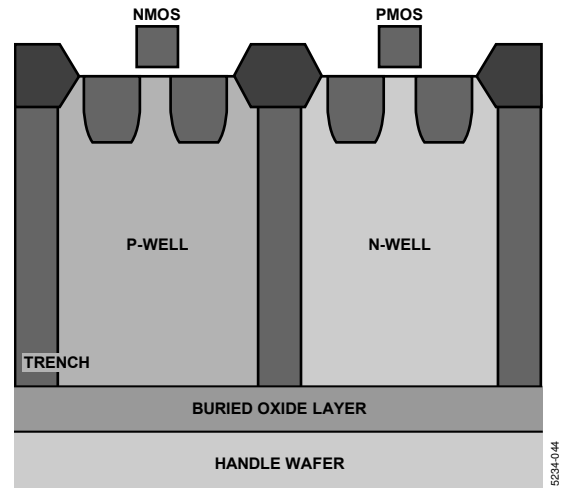

Figure 46. Trench Isolation

## DIGITAL INPUT BUFFERS

There are input buffers present on the digital inputs pins  $\overline{CS}$ , SCLK, and SDI. These buffers are active at all times. As result of this, there will be current draw from the  $V_L$  supply if SCLK or SDI are toggling, regardless whether  $\overline{CS}$  is active. For typical values of this current draw, refer to the specification tables and Figure 26.

## APPLICATIONS INFORMATION

### POWER SUPPLY RAILS

To guarantee correct operation of the ADGS5412, 0.1  $\mu\text{F}$  decoupling capacitors are required.

The ADGS5412 can operate with bipolar supplies between  $\pm 9\text{ V}$  and  $\pm 22\text{ V}$ . The supplies on  $V_{\text{DD}}$  and  $V_{\text{SS}}$  do not have to be symmetrical; however, the  $V_{\text{DD}}$  to  $V_{\text{SS}}$  range must not exceed 44 V. The ADGS5412 can also operate with single supplies between 9 V and 40 V with  $V_{\text{SS}}$  connected to GND.

The voltage range that can be supplied to  $\overline{\text{RESET}}/V_{\text{L}}$  is from 2.7 V to 5.5 V.

The device is fully specified at  $\pm 15\text{ V}$ ,  $\pm 20\text{ V}$ ,  $+12\text{ V}$ , and  $+36\text{ V}$  analog supply voltage ranges.

### POWER SUPPLY RECOMMENDATIONS

Analog Devices, Inc. has a wide range of power management products to meet the requirements of most high performance signal chains.

An example of a bipolar power solution is shown in Figure 47. The ADP5070 (dual switching regulator) generates a positive and negative supply rail for the ADGS5412, amplifier, and/or a precision converter in a typical signal chain. Also shown in Figure 47 are two optional LDOs, ADP7118 and ADP7182,

positive and negative low dropout regulators (LDOs), respectively, that can be used to reduce the output ripple of the ADP5070 in ultralow noise sensitive applications.

The ADM7160 can be used to generate the  $\overline{\text{RESET}}/V_{\text{L}}$  voltage that is required to power digital circuitry within the ADGS5412.

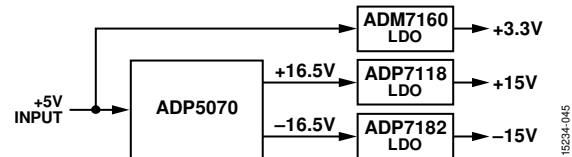

Figure 47. Bipolar Power Solution

Table 10. Recommended Power Management Devices

Product	Description
ADP5070	1 A/0.6 A, dc-to-dc switching regulator with independent positive and negative outputs
ADM7160	5.5 V, 200 mA, ultralow noise, linear regulator
ADP7118	20 V, 200 mA, low noise, CMOS LDO linear regulator
ADP7182	-28 V, -200 mA, low noise, LDO linear regulator

## REGISTER SUMMARY

Table 11. Register Summary

Reg.	Name	Bits	Bit 7	Bit 6	Bit 5	Bit 4	Bit 3	Bit 2	Bit 1	Bit 0	Default	RW		
0x01	SW_DATA	[7:0]	Reserved				SW4_EN	SW3_EN	SW2_EN	SW1_EN		0x00	R/W	
0x02	ERR_CONFIG	[7:0]	Reserved					RW_ERR_EN	SCLK_ERR_EN	CRC_ERR_EN		0x06	R/W	
0x03	ERR_FLAGS	[7:0]	Reserved					RW_ERR_FLAG	SCLK_ERR_FLAG	CRC_ERR_FLAG		0x00	R	
0x05	BURST_EN	[7:0]	Reserved								BURST_MODE_EN		0x00	R/W
0x0B	SOFT_RESETB	[7:0]	SOFT_RESETB										0x00	R/W

## REGISTER DETAILS

### SWITCH DATA REGISTER

**Address: 0x01, Reset: 0x00, Name: SW\_DATA**

The switch data register controls the status of the four switches of the ADGS5412.

**Table 12. Bit Descriptions for SW\_DATA**

Bits	Bit Name	Settings	Description	Default	Access
[7:4]	Reserved		These bits are reserved; set these bits to 0.	0x0	R
3	SW4_EN	0 1	Enable bit for SW4. SW4 open. SW4 closed.	0x0	R/W
2	SW3_EN	0 1	Enable bit for SW3. SW3 open. SW3 closed.	0x0	R/W
1	SW2_EN	0 1	Enable bit for SW2. SW2 open. SW2 closed.	0x0	R/W
0	SW1_EN	0 1	Enable bit for SW1. SW1 open. SW1 closed.	0x0	R/W

### ERROR CONFIGURATION REGISTER

**Address: 0x02, Reset: 0x06, Name: ERR\_CONFIG**

The error configuration register allows the user to enable/disable the relevant error features as required.

**Table 13. Bit Descriptions for ERR\_CONFIG**

Bits	Bit Name	Settings	Description	Default	Access
[7:3]	Reserved		These bits are reserved; set these bits to 0.	0x0	R
2	RW_ERR_EN	0 1	Enable bit for detecting an invalid read/write address. Disabled. Enabled.	0x1	R/W
1	SCLK_ERR_EN	0 1	Enable bit for detecting the correct number of SCLK cycles in an SPI frame. When CRC is disabled and burst mode is disabled, 16 SCLK cycles are expected. When CRC is enabled and burst mode is disabled, 24 SCLK cycles are expected. A multiple of 16 SCLK cycles is expected when CRC is disabled and burst mode is enabled. A multiple of 24 SCLK cycles is expected when CRC is enabled and burst mode is enabled. Disabled. Enabled.	0x1	R/W
0	CRC_ERR_EN	0 1	Enable bit for CRC error detection. SPI frames must be 24 bits wide when enabled. Disabled. Enabled.	0x0	R/W

**ERROR FLAGS REGISTER****Address: 0x03, Reset: 0x00, Name: ERR\_FLAGS**

The error flags register allows the user to determine if an error occurred. To clear the error flags register, write the special 16-bit SPI command, 0x6CA9, to the device. This SPI command does not trigger the invalid R/W address error. When CRC is enabled then the user must include the correct CRC byte during the SPI write in order for the clear error flags register command to be successful.

**Table 14. Bit Descriptions for ERR\_FLAGS**

Bits	Bit Name	Settings	Description	Default	Access
[7:3]	Reserved		These bits are reserved and are set to 0.	0x0	R
2	RW_ERR_FLAG	0 1	Error flag for invalid read/write address. The error flag asserts during an SPI read if the target address does not exist. The error flag also asserts when the target address of an SPI write does not exist or is read only. No error. Error.	0x0	R
1	SCLK_ERR_FLAG	0 1	Error flag for the detection of the correct number of SCLK cycles in an SPI frame. No error. Error.	0x0	R
0	CRC_ERR_FLAG	0 1	Error flag that determines if a CRC error occurred during a register write. No error. Error.	0x0	R

**BURST ENABLE REGISTER****Address: 0x05, Reset: 0x00, Name: BURST\_EN**

The burst enable register allows the user to enable or disable the burst mode. When enabled, the user can send multiple consecutive SPI commands without de-asserting CS.

**Table 15. Bit Descriptions for BURST\_EN**

Bits	Bit Name	Settings	Description	Default	Access
[7:1]	Reserved		These bits are reserved; set these bits to 0.	0x0	R
0	BURST_MODE_EN	0 1	Burst mode enable bit. Disabled. Enabled.	0x0	R/W

**SOFTWARE RESET REGISTER****Address: 0x0B, Reset: 0x00, Name: SOFT\_RESETB**

This register is used to perform a software reset. Consecutively write 0xA3 and 0x05 to this register and the device registers reset to their default states.

**Table 16. Bit Descriptions for SOFT\_RESETB**

Bits	Bit Name	Settings	Description	Default	Access
[7:0]	SOFT_RESETB		To perform a software reset, consecutively write 0xA3 followed by 0x05 to this register.	0x0	R/W

OUTLINE DIMENSIONS

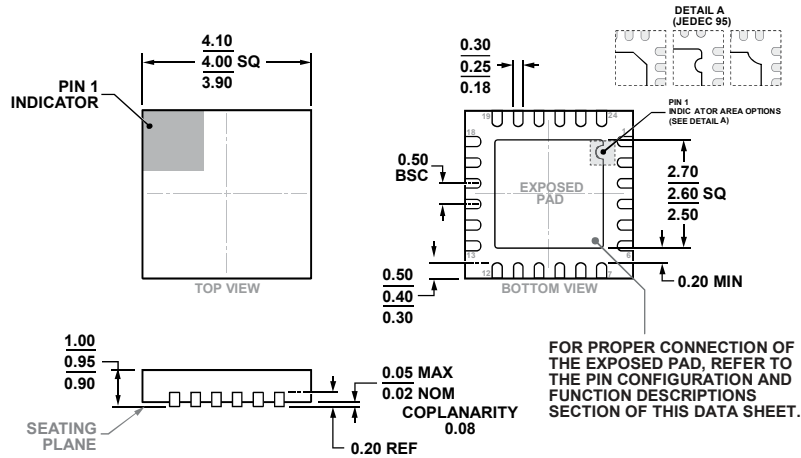

COMPLIANT TO JEDEC STANDARDS MO-220-VGGD-8.

Figure 48. 24-Lead Lead Frame Chip Scale Package [LFCSP]  
 4 mm × 4 mm Body and 0.95 mm Package Height  
 (CP-24-17)

Dimensions shown in millimeters

ORDERING GUIDE

Model <sup>1</sup>	Temperature Range	Package Description	Package Option
ADGS5412BCPZ	−40°C to +125°C	24-Lead Lead Frame Chip Scale Package [LFCSP]	CP-24-17
ADGS5412BCPZ-RL7	−40°C to +125°C	24-Lead Lead Frame Chip Scale Package [LFCSP]	CP-24-17
EVAL-ADGS5412SDZ		Evaluation Board	

<sup>1</sup> Z = RoHS Compliant Part.