

Multiband GNSS Dielectric Patch Antenna



APARM1504-SG3



15.0 x 15.0 x 4.0 mm
RoHS/RoHS II Compliant
MSL = N/A

Features

- Multiband GNSS patch with GPS/GLONASS/BeiDou/Galileo
- Low VSWR of 1.8
- RHCP polarization
- Compact 15.0 x 15.0 x 4.0 mm patch

Applications

- GPS/GLONASS/BeiDou/Galileo applications
- IoT
- M2M
- Remote technology monitoring
- Geofencing
- Navigation
- Surveying and mapping systems
- Logistics
- Automotive

Electrical Specifications

Parameters	Min.	Typ.	Max.	Units	Note
Frequency Range		GPS: 1575.42 ± 1.023 GLONASS: 1602 ± 5 BeiDou: 1561.098 ± 2.046		MHz	
VSWR			1.8		@CF
Polarization		RHCP			Right Hand Circular Polarization
Impedance		50		Ω	
Gain		GPS : - 4.5 GLONASS : 0.8 BeiDou : - 3.0		dBi	Zenith

* Ground Plane size: 46.35 × 41.57 mm

* Actual Electrical Value will depend on the size of ground plane in use

Environmental Characteristics

Parameters	Description
Operating Temperature	-40°C to +105°C
Storage Temperature	-40°C to +105°C
Frequency Temperature Coefficient	-40°C to +105°C (0 ± 20 ppm/ °C)
Relative Humidity	0 ~ 95 %

Multiband GNSS Dielectric Patch Antenna



APARM1504-SG3



15.0 x 15.0 x 4.0 mm
RoHS/RoHS II Compliant
MSL = N/A

Product Dimensions

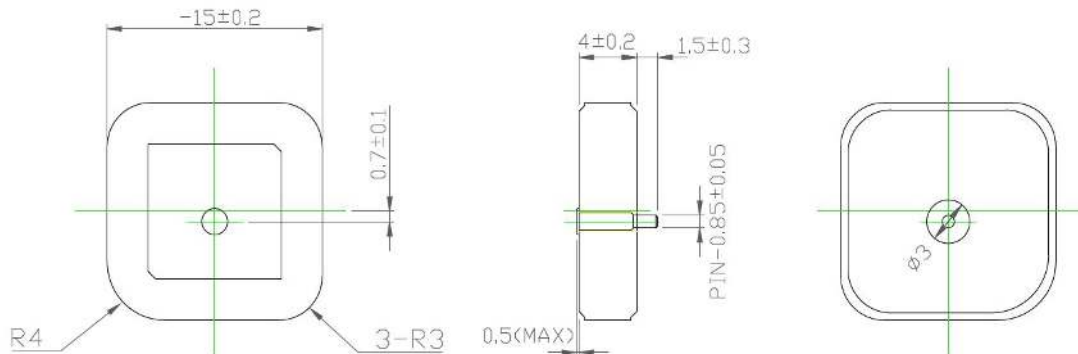

Layout Dimensions (Unit: mm)

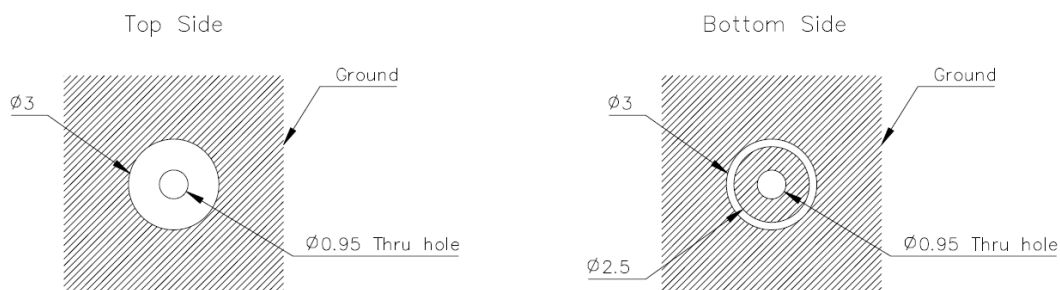

TOL : ±0.2

Tape Dimension (Unit: mm)

Thickness : 0.05 (± 0.02) mm (Double sized very thin tape)

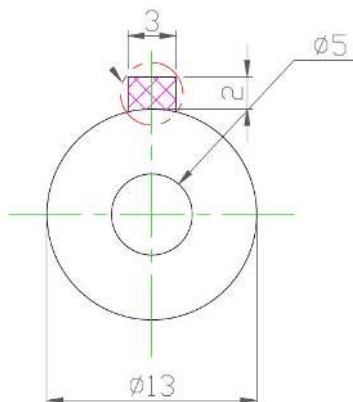

Multiband GNSS Dielectric Patch Antenna



APARM1504-SG3



15.0 x 15.0 x 4.0 mm
RoHS/RoHS II Compliant
MSL = N/A

VSWR

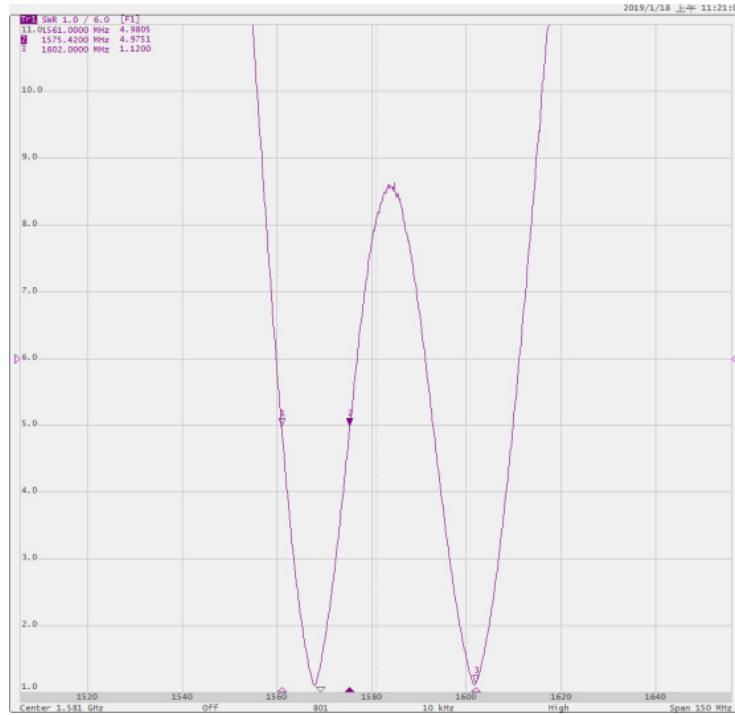

Return Loss

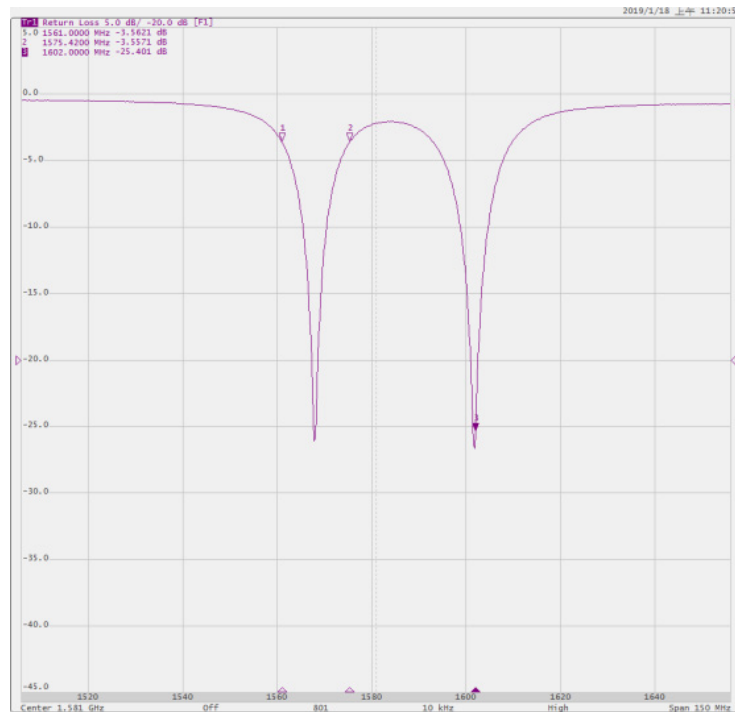

Multiband GNSS Dielectric Patch Antenna



APARM1504-SG3



15.0 x 15.0 x 4.0 mm
RoHS/RoHS II Compliant
MSL = N/A

Impedance Characteristics

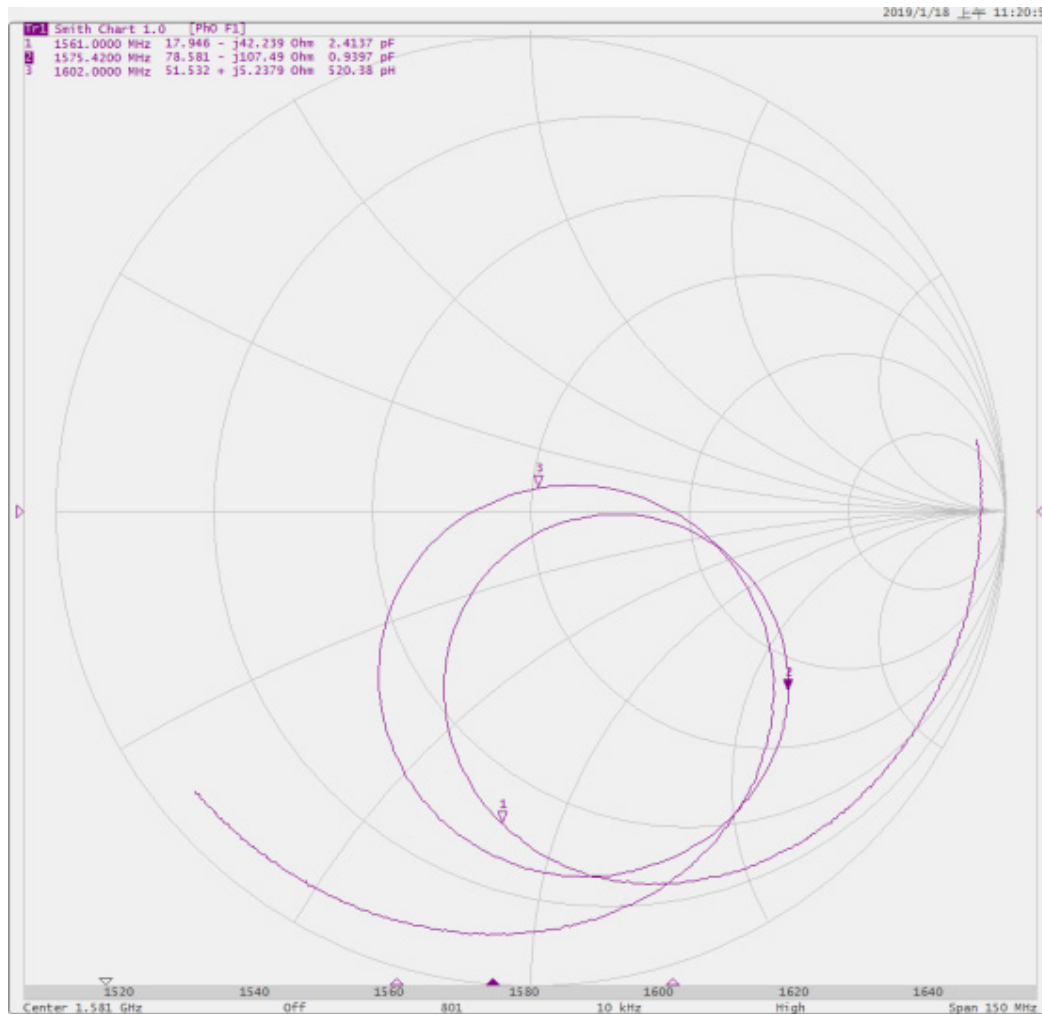

Multiband GNSS Dielectric Patch Antenna



APARM1504-SG3



15.0 x 15.0 x 4.0 mm
RoHS/RoHS II Compliant
MSL = N/A

Radiation Patterns

XZ-Plane

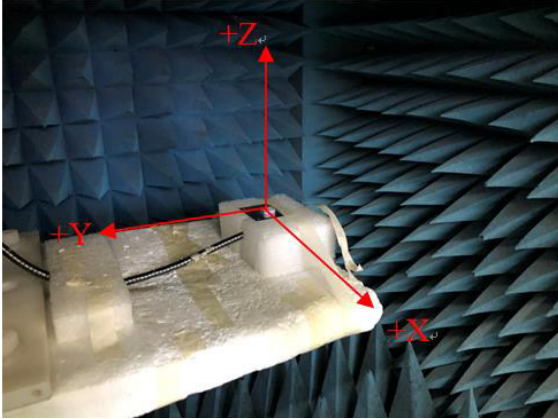

YZ-Plane

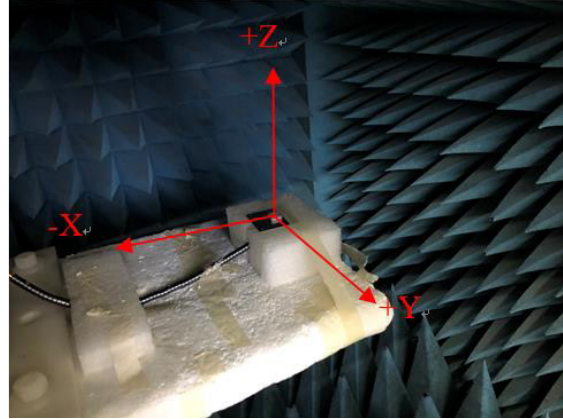

XZ + YZ – Plane : 1561 MHz

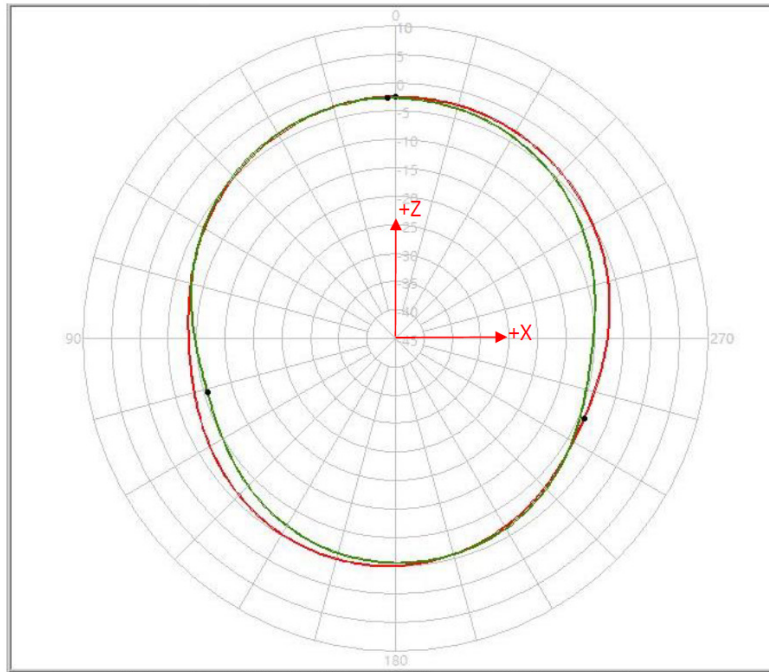

1561 MHz	Peak Gain	Zenith Gain (dBi)
XZ	-2.44	-2.44
YZ	-2.64	-2.65

Multiband GNSS Dielectric Patch Antenna



APARM1504-SG3



15.0 x 15.0 x 4.0 mm
RoHS/RoHS II Compliant
MSL = N/A

Radiation Patterns

XZ + YZ – Plane : 1575.42 MHz

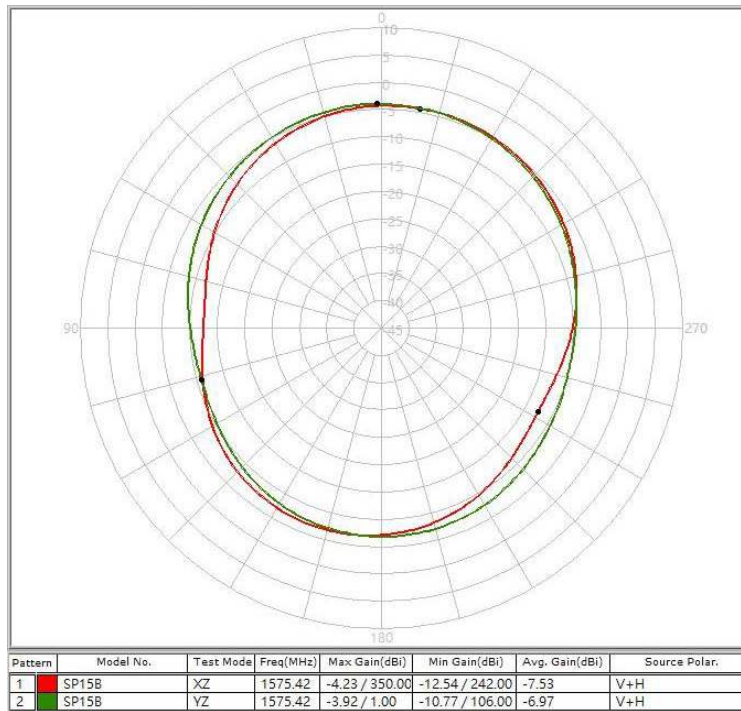

1575.42 MHz	Peak Gain	Zenith Gain (dBi)
XZ	-4.23	-4.28
YZ	-3.92	-3.92

Multiband GNSS Dielectric Patch Antenna



APARM1504-SG3



15.0 x 15.0 x 4.0 mm
RoHS/RoHS II Compliant
MSL = N/A

Radiation Patterns

XZ + YZ – Plane : 1602 MHz

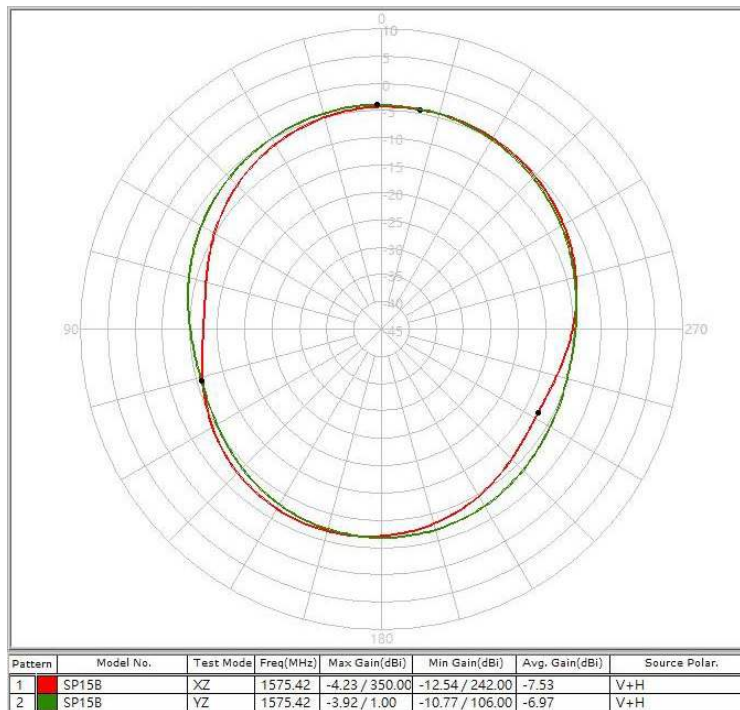

1602 MHz	Peak Gain	Zenith Gain (dBi)
XZ	1.12	1.12
YZ	1.46	1.46

Packaging

The carton is of dimension 330 x 280 x 254 mm and contains over 1600 antennas.

Multiband GNSS Dielectric Patch Antenna



APARM1504-SG3



15.0 x 15.0 x 4.0 mm
RoHS/RoHS II Compliant
MSL = N/A

Reliability Tests

- i. Low-temperature test: Expose the specimen to -40°C for 400 hours and then to normal temperature/ humidity for 24 hours or more. After this test, examine its appearance and functions.
- ii. High-temperature test: Expose the specimen to $+105^{\circ}\text{C}$ for 400 hours and then to normal temperature/humidity for 24 hours or more. After this test, examine its appearance and functions.
- iii. High-temperature/ High-humidity test: Subject the object to the environmental conditions of $+60^{\circ}\text{C}$ and 90 – 95 % R.H. for 96 hours, then expose to normal temperature/ humidity for 24 hours or more. After this test, examine its appearance and functions.
- iv. Thermal shock test: Subject the object to cyclic temperature change (-40°C , 2 hours \leftrightarrow $+85^{\circ}\text{C}$, 2 hours) for 100 cycles, the expose to normal temperature/humidity for 24 hours or more.
- v. Vibration test:
 - Sinusoidal vibration test: Subject the object to vibrations of 5 to 200 to 5 Hz swept in 10 minutes, 4.5 G at maximum (2 mm amplitude), in X and Y directions for two hours each and in Z direction for four hours. After this test, examine its appearance functions.
 - Vibration test in packaged condition: Subject the object, which is packed as illustrated, to vibrations of 15 to 60 to 15 Hz swept in 6 minutes, 4 G at maximum (2 mm amplitude at maximum), applied in X, Y and Z directions for two hours each, i.e. six hours in total. After this test, examine its appearance and functions.
- vi. Free fall test in packaged condition: Drop the object, which is packed as illustrated, to a concrete surface from the height of 90 cm, on one corner, three edges and six faces once each, i.e. 10 times in total. After this, check the appearance and functions.
- vii. Soldering heat resistance test: After the lead pins of the unit are soaked in solder bath at $260^{\circ}\text{C} \pm 5^{\circ}\text{C}$ for 10 seconds. After this test, examine its appearance and functions.
- viii. Adhesion test: The device is subjected to be soldered on test PCB. Then apply 0.5 Kg (5 N) of force for 5 ± 1 seconds in the direction parallel to the substrate. (The soldering should be done by reflow and be conducted with care so that the soldering is uniform and free of defect by stress such as heat shock).

ATTENTION: Abracon LLC's products are COTS – Commercial-Off-The-Shelf products; suitable for Commercial, Industrial and, where designated, Automotive Applications. Abracon's products are not specifically designed for Military, Aviation, Aerospace, Life-dependent Medical applications or any application requiring high reliability where component failure could result in loss of life and/or property. For applications requiring high reliability and/or presenting an extreme operating environment, written consent and authorization from Abracon LLC is required. Please contact Abracon LLC for more information.



5101 Hidden Creek Ln Spicewood TX 78669
Phone: 512-371-6159 | Fax: 512-351-8858
For terms and conditions of sales, please visit:
www.abracon.com

REVISED: 01.25.2019

ABRACON IS
ISO9001-2015
CERTIFIED