

FC-23629-P16
SHT I. I

NOTE:

NOT PICTURED: SILICONE TUBE FOR STRAIN RELIEF

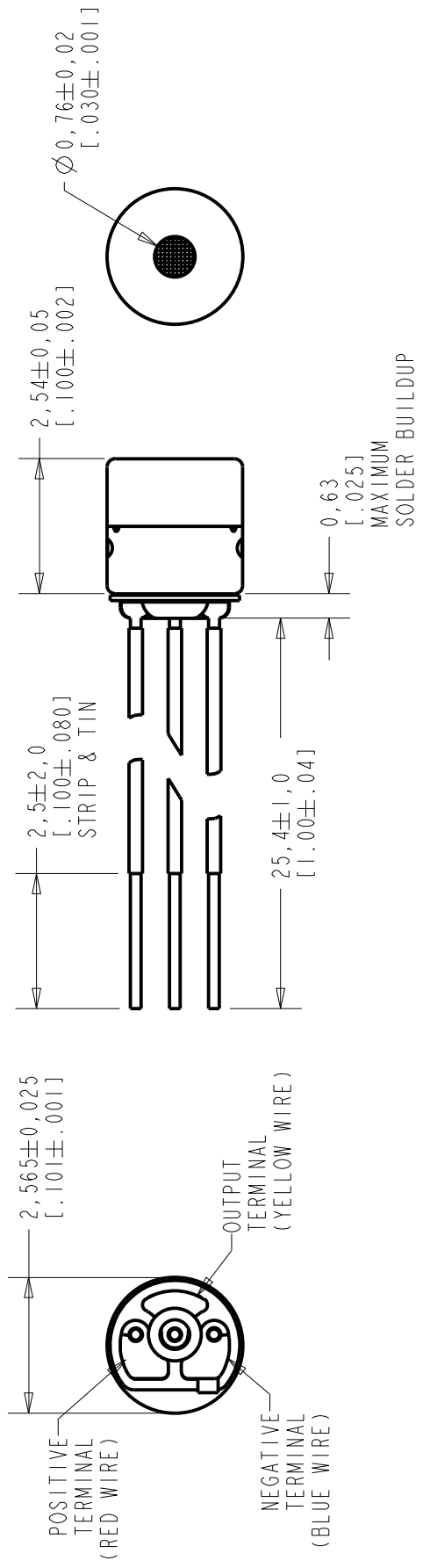

Revision	C.O. #	Implementation Date	RELEASE LEVEL	REVISION
C	M10103048	8-7-09	Active	C
B	M10102044	12-26-08		
A	M10100967	1-23-06		

SCALE: 2:1	
DO NOT SCALE DRAWING	
TITLE: MICROPHONE / CABLE	FC-23629-P16
OUTLINE DRAWING SHT I. I	

DR. BY	DATE
MM	1-23-06
CK. BY	DATE
GJP	1-25-06
APP. BY	DATE
GJP	1-25-06

DIMENSIONS IN MILLIMETERS [INCHES]

KNOWLES ELECTRONICS
ITASCA, ILLINOIS U.S.A.

SENSITIVITY IN dB RELATIVE TO 1.0 VOLT/0.1 Pa (N/M²)
FOR CONDITIONS SHOWN BELOW.

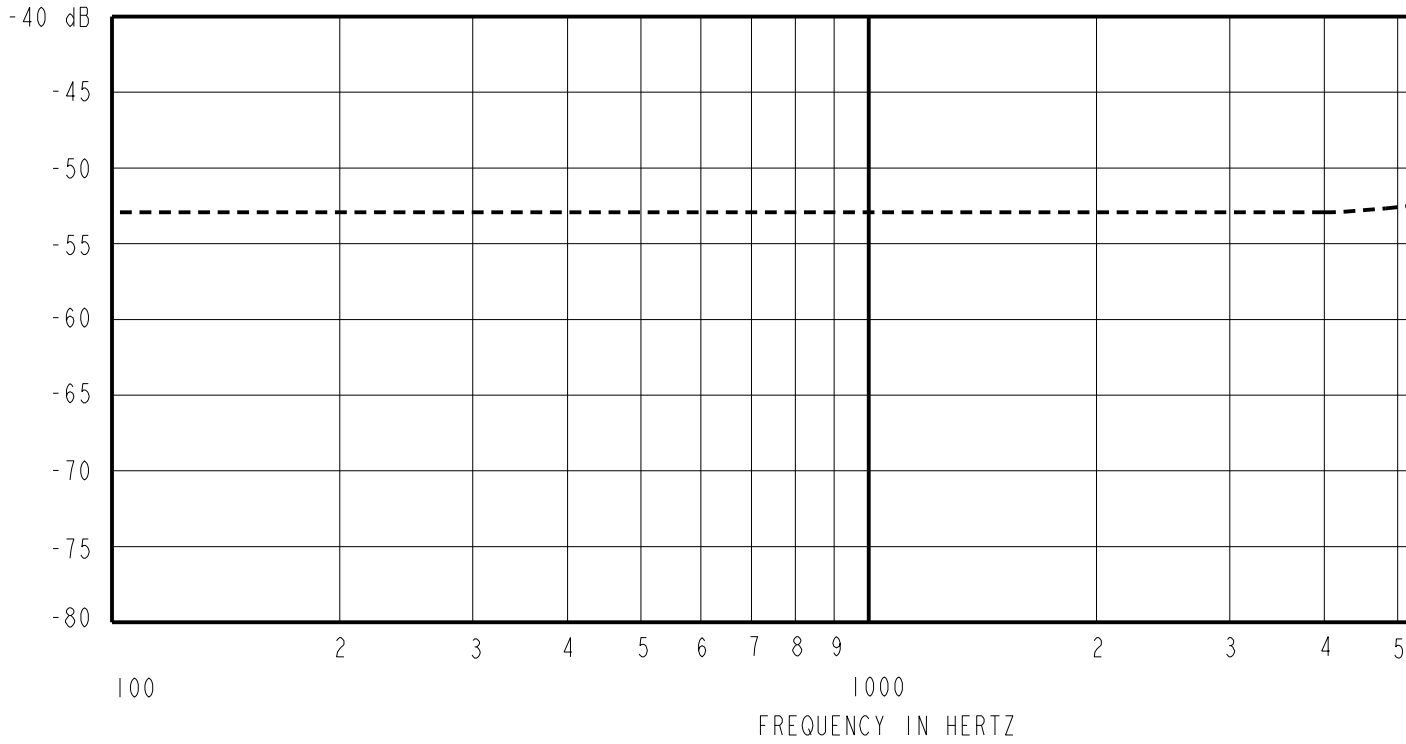

FREQUENCY	SENSITIVITY			DEVICE CONFORMI
	MIN.	NOM.	MAX.	RANGE OF DEVIATION FR
100	---	-53.0	---	-3.0
1000	-56.0	-53.0	-50.0	0.0
10000	---	-50.0	---	0.0

NOTES:

1. CASE CONNECTED TO NEGATIVE TERMINAL.
2. MICROPHONE TO BE FUNCTIONAL WITH 3.0 VDC SUPPLY.
3. TYPICAL SENSITIVITY TO HUMIDITY AT 1000Hz IS 0.06 dB/%RH.
4. SENSITIVITY AND NOISE VALUES INDICATED ON THIS SPECIFICATION ARE VALID AT 50% HUMIDITY.

PORT LOCATION	DC SUPPLY	AMPLIFIER CURRENT DRAIN	SENSITIVITY CHANGE ON REDUCING SUPPLY TO 0.9VDC	"A" WEIGHTED NOISE (1 kHz EQUIV. SPL)	OUTPUT IMPEDANCE OHMS			C
					MIN.	NOM.	MAX.	
12S	1.3V	50 µA MAX.	3 dB MAX.	28.0 dB MAX.	2800	4400	6800	