

NUMBER OF CIRCUITS "XX"	DIM. A		DIM. B		DIM. C		DIM. D	
	IN	MM	IN	MM	IN	MM	IN	MM
01	1.21	30.7	-	-	.75	19.1	.46	11.7
02	1.58	40.1	.375	9.53	1.13	28.7	.83	21.1
03	1.96	49.7	.750	19.05	1.50	38.1	1.21	30.7
04	2.33	59.2	1.125	28.58	1.88	47.7	1.58	40.1
05	2.71	68.8	1.500	38.10	2.25	57.2	1.96	49.8
06	3.08	78.2	1.875	47.63	2.63	66.8	2.33	59.2
07	3.46	87.9	2.250	57.15	3.00	76.2	2.71	68.8
08	3.83	97.3	2.625	66.68	3.38	85.9	3.08	78.2
09	4.21	106.9	3.000	76.20	3.75	95.3	3.46	87.8
10	4.58	116.3	3.375	85.73	4.13	104.9	3.83	97.3
11	4.96	126.0	3.750	95.25	4.50	114.3	4.21	106.9
12	5.33	135.4	4.125	104.78	4.88	123.9	4.58	116.3
13	5.71	145.0	4.500	114.30	5.25	133.4	4.96	126.0
14	6.08	154.4	4.875	123.83	5.63	143.0	5.33	135.4
15	6.46	164.0	5.250	133.35	6.00	152.4	5.71	145.0
16	6.83	173.5	5.625	142.88	6.38	162.0	6.08	154.4
17	7.21	183.1	6.000	152.40	6.75	171.5	6.46	164.0
18	7.58	192.5	6.375	161.93	7.13	181.1	6.84	173.7
19	7.96	202.2	6.750	171.45	7.50	190.5	7.21	183.1
20	8.33	211.6	7.125	180.98	7.88	200.2	7.58	192.5
21	8.71	221.2	7.500	190.50	8.25	209.6	7.96	202.2
22	9.08	230.6	7.875	200.03	8.63	219.2	8.33	211.6
23	9.46	240.3	8.250	209.55	9.00	228.6	8.71	221.2
24	9.83	249.7	8.625	219.08	9.38	238.2	9.08	230.6
25	10.21	259.3	9.000	228.60	9.75	247.7	9.46	240.3
26	10.58	268.7	9.375	238.13	10.13	257.3	9.83	250.0

P/N LEGEND

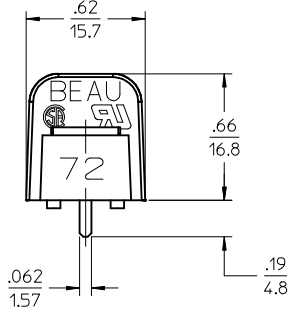
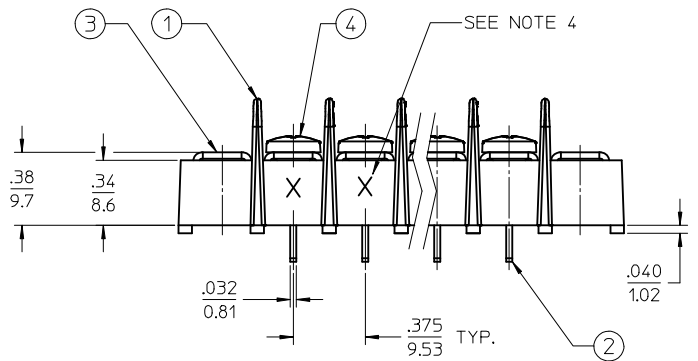
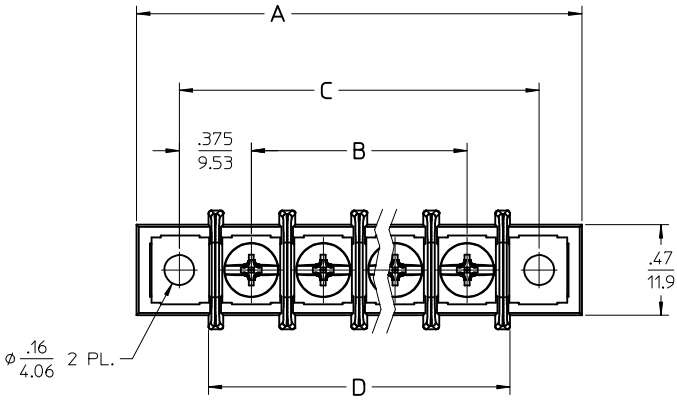
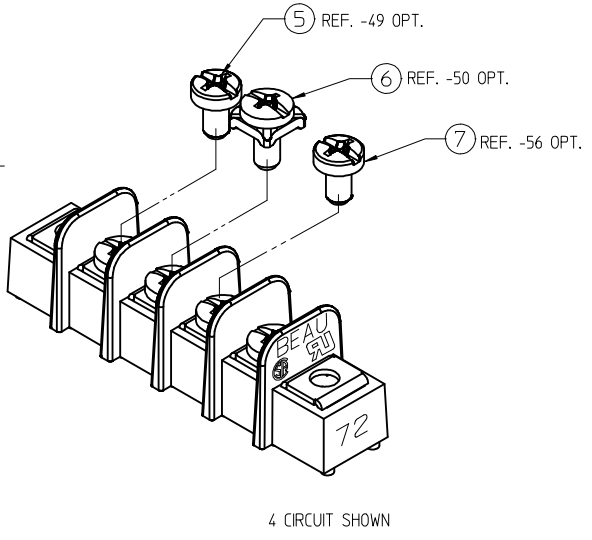
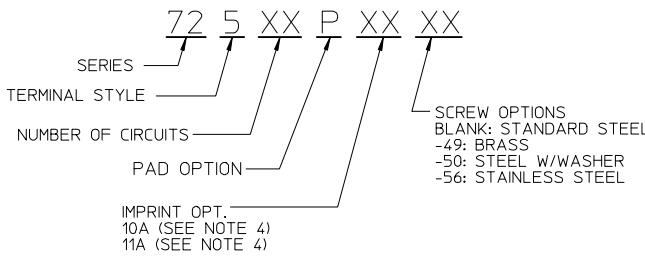

- NOTES:
1. MATERIAL: SEE TABLE
 2. FINISH: SEE TABLE
 3. ELECTRICAL SPECS:
MAX VOLTAGE: 300V (BINDING HD, 14 AWG)
MAX CURRENT: 15A

MAX VOLTAGE: 300V (-50 OPT, 12 AWG)
MAX CURRENT: 25A
 4. REFER TO SD-38120-001 FOR IMPRINT OPTION 10A & 11A
 5. PRODUCT SPEC: PS-38710-001
 6. SCREW TIGHTENING TORQUE: 12 IN LBS. (MAX)
 7. WIRE STRIP LENGTH: .31 (7.8mm)
 8. PART IS RoHS COMPLIANT

7	XX	SCREW, #6-32X.250, PHIL-SLOT, BHD -56 OPT	ST. STEEL	PASSIVATED
6	XX	SCREW, #6-32X.250, PHIL-SLOT, SQ. WASHER (-50 OPT)	STEEL	ZINC, CLEAR CHROMATE
5	XX	SCREW, #6-32X.250, PHIL-SLOT, BHD -49 OPT	BRASS	NICKEL PLATED
4	XX	SCREW, #6-32X.250, PHIL-SLOT, BHD	STEEL	ZINC, CLEAR CHROMATE
3	2	PLATE, MTG.	BRASS	NICKEL PLATED
2	XX	TERMINAL, PC	BRASS	TIN PLATED
1	1	INSULATOR, SR, RAISED PADS	PBT	BLACK
ITEM	QTY.	DESCRIPTION	MATERIAL	FINISH

RELEASED EC NO: IPGZ2015-2082 DRWR:RSTONE 2015/06/04 CHKD:B RUPERT 2015/06/08 APPR:JFMURPHY 2015/06/08 REV:	QUALITY SYMBOLS $\nabla=0$ $\nabla=0$	GENERAL TOLERANCES (UNLESS SPECIFIED) <table border="1"> <thead> <tr> <th></th> <th>mm</th> <th>INCH</th> </tr> </thead> <tbody> <tr> <td>4 PLACES</td> <td>± .005</td> <td>± .0004</td> </tr> <tr> <td>3 PLACES</td> <td>± .005</td> <td>± .0004</td> </tr> <tr> <td>2 PLACES</td> <td>± .005</td> <td>± .0004</td> </tr> <tr> <td>1 PLACE</td> <td>± 0.3</td> <td>± .012</td> </tr> <tr> <td>0 PLACE</td> <td>± .005</td> <td>± .0004</td> </tr> </tbody> </table>		mm	INCH	4 PLACES	± .005	± .0004	3 PLACES	± .005	± .0004	2 PLACES	± .005	± .0004	1 PLACE	± 0.3	± .012	0 PLACE	± .005	± .0004	DIMENSION STYLE IN/MM	SCALE 2:1	DESIGN UNITS INCH	THIRD ANGLE PROJECTION
				mm	INCH																			
4 PLACES	± .005	± .0004																						
3 PLACES	± .005	± .0004																						
2 PLACES	± .005	± .0004																						
1 PLACE	± 0.3	± .012																						
0 PLACE	± .005	± .0004																						
DRAFT WHERE APPLICABLE MUST REMAIN WITHIN DIMENSIONS	ANGULAR ± 1°	DRAWN BY RSTONE 2015/06/04	DATE 2015/06/04	CHECKED BY B RUPERT 2015/06/08	DATE 2015/06/08	APPROVED BY JFMURPHY 2015/06/08	DATE 2015/06/08																	
MATERIAL NO. SEE CHART		DOCUMENT NO. SD-38720-014		SHEET NO. 1 OF 1		THIS DRAWING CONTAINS INFORMATION THAT IS PROPRIETARY TO MOLEX INCORPORATED AND SHOULD NOT BE USED WITHOUT WRITTEN PERMISSION																		