

**FineAdjust  
Applicator**

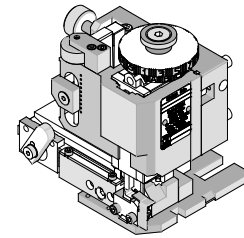

**Application Tooling  
Specification Sheet**



**Order No. 63903-2600**

**FEATURES THIS APPLICATOR IS FOR AUTOMATIC WIRE PROCESSOR USE ONLY.**

- Quick punch removal with the push of a button for fast and easy tooling change
- Applicator designed to industry standard mounting and shut height 135.80mm (5.346")
- Quick set-up time; plus the crimp height, track and feed adjustments can be set without removing the applicator from the press
- Fine adjustment allows users to achieve target with little effort by adjusting in increments of .015mm (.0006") for conductor crimp height and .063mm (.0025") for insulation height
- Independent adjustment rings allow users to quickly adjust the conductor or insulation crimp height without affecting each other
- Directly adapts to most automatic wire processing machines

**SCOPE**

Products: CTX64 Mat Seal Receptacle Terminals 0.22mm<sup>2</sup>, 0.30mm<sup>2</sup>, 0.35mm<sup>2</sup> and 22 AWG.

7.0mm Terminal Progression									
Terminal Series No.	Terminal Order No.			Wire Size		Insulation Diameter		Strip Length	
				AWG	mm <sup>2</sup>	mm	In.	mm	In.
502306	502306-3111	502306-3403	502306-5303	-	0.22-0.35	1.10-1.65	.043-.065	4.00-4.50	.158-.177
	502306-3211	502306-3411		22 AWG	-				
34803	34803-3111	34803-3403	34803-5303	-	0.22-0.35	1.10-1.65	.043-.065	4.00-4.50	.158-.177
	34803-3211	34803-3411		22 AWG	-				
34863	34863-3211	34863-3403	34863-3411	-	0.22-0.35	1.10-1.65	.043-.065	4.00-4.50	.158-.177
		34863-3411		22 AWG	-				
34970	34970-3111	34970-3403	34970-5303	-	0.22-0.35	1.10-1.65	.043-.065	4.00-4.50	.158-.177
	34970-3211	34970-3411		22 AWG	-				

8.3mm Terminal Progression									
Terminal Series No.	Terminal Order No.			Wire Size		Insulation Diameter		Strip Length	
				AWG	mm <sup>2</sup>	mm	In.	mm	In.
502306	502306-0111	502306-0221	502306-0411	-	0.22-0.35	1.10-1.65	.043-.065	4.00-4.50	.158-.177
	502306-0121	502306-0403	502306-2303	22 AWG	-				
	502306-0211	502306-0404	502306-2304		-				
34803	34803-0111	34803-0221	34803-0411	-	0.22-0.35	1.10-1.65	.043-.065	4.00-4.50	.158-.177
	34803-0121	34803-0403	34803-2303	22 AWG	-				
	34803-0211	34803-0404	34803-2304		-				
34863	34863-0211	34863-0403	34863-0411	-	0.22-0.35	1.10-1.65	.043-.065	4.00-4.50	.158-.177
				22 AWG	-				

### DEFINITION OF TERMS

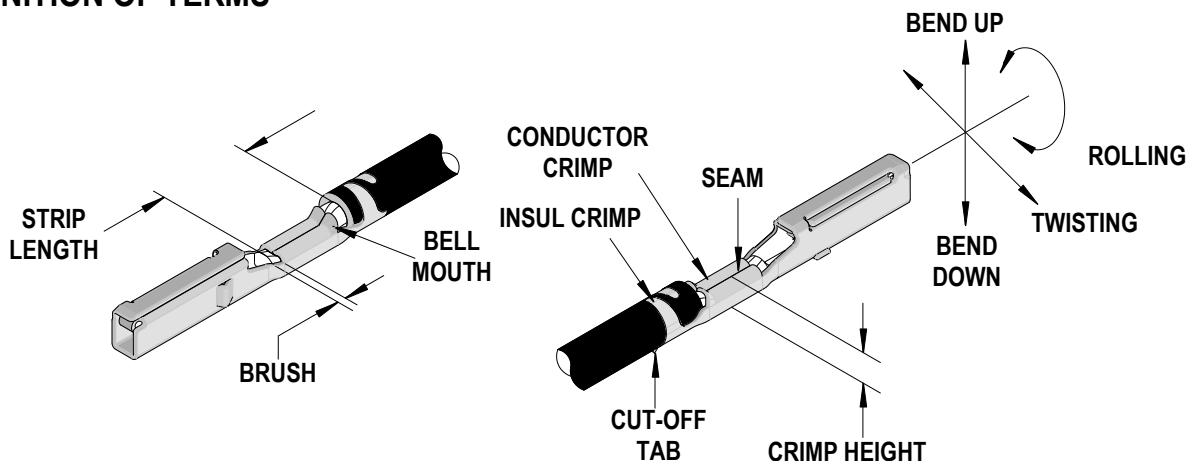

### CRIMP SPECIFICATION

Terminal Series No.	Bell mouth		Cut-off Tab Maximum		* Conductor Brush	
	mm	In.	mm	In.	mm	In.
502306	0.20-0.55	.008-.022	0.30	.012	0.20-1.00	.008-.039
34803						
34863						
34970						

\* Wire brush must be flush or below top of Conductor Crimp.

**THIS APPLICATOR IS INTENDED FOR AUTOMATIC WIRE PROCESSOR USE ONLY.**

It is very important that the brush length is consistently within specification for this sealed connector system to work properly.

This applicator should only be run in a properly setup automatic wire processor to consistently achieve the brush length.

Any attempt to use this applicator outside a properly setup automatic wire processor will likely not meet the brush specification and may cause this sealed connector system to not work properly.

Terminal Series No.	Bend up	Bend down	Twist	Roll	Punch Width (Ref)				Seam Seam shall not be open and no wire allowed out of the crimping area
					Conductor		Insulation		
	Degree (Max)		Degree (Max)		mm	In	mm	In	
502306	1	2	4	6	1.30	.051	1.45	.057	
34803									
34863									
34970									

After crimping, the crimp profiles should measure the following:

7.0mm Terminal Progression														
Terminal Plating	Terminal Order No.		Wire Size		Conductor				Insulation				Pull Force Minimum	
					Crimp Height		Crimp Width (Ref)		Crimp Height Maximum		Crimp Width Maximum			
			Wire Type	mm <sup>2</sup> / AWG	mm	In.	mm	In.	mm	In.	mm	In.	N	Lb.
Standard Performance Tin	502306-3111 502306-3211 34803-3111 34803-3211	34863-3211 34970-3111 34970-3211	FLRY-A	0.22	0.62-0.68	.024-.027	1.30	.051	1.50	.059	1.60	.063	35	7.9
Standard Performance Tin	502306-3111 502306-3211 34803-3111 34803-3211	34863-3211 34970-3111 34970-3211	B2M	0.22	0.62-0.68	.024-.027	1.30	.051	1.50	.059	1.60	.063	60	13.5
Standard Performance Tin	502306-3111 502306-3211 34803-3111 34803-3211	34863-3211 34970-3111 34970-3211	T3ZHID	0.35	0.66-0.72	.026-.028	1.30	.051	1.70	.067	1.60	.063	60	13.5
High Performance Tin	502306-3403 502306-3411 34803-3403 34803-3411	34863-3403 34863-3411 34970-3403 34970-3411	T3ZHID	0.35	0.66-0.72	.026-.028	1.30	.051	1.70	.067	1.60	.063	60	13.5
High Performance Silver	502306-5303 34803-5303	34970-5303	T3ZHID	0.35	0.66-0.72	.026-.028	1.30	.051	1.70	.067	1.60	.063	60	13.5
Standard Performance Tin	502306-3111 502306-3211 34803-3111 34803-3211	34863-3211 34970-3111 34970-3211	A3	0.35	0.66-0.72	.026-.028	1.30	.051	1.95	.077	1.60	.063	60	13.5
High Performance Tin	502306-3403 502306-3411 34803-3403 34803-3411	34863-3403 34863-3411 34970-3403 34970-3411	A3	0.35	0.66-0.72	.026-.028	1.30	.051	1.95	.077	1.60	.063	60	13.5
Standard Performance Tin	502306-3111 502306-3211 34803-3111 34803-3211	34863-3211 34970-3111 34970-3211	AVSS	0.30	0.72-0.78	.028-.031	1.30	.051	1.80	.071	1.60	.063	60	13.5
Standard Performance Tin	502306-3111 502306-3211 34803-3111 34803-3211	34863-3211 34970-3111 34970-3211	TXL	22 AWG	0.66-0.72	.026-.028	1.30	.051	1.80	.071	1.60	.063	60	13.5
High Performance Tin	502306-3403 502306-3411 34803-3403 34803-3411	34863-3403 34863-3411 34970-3403 34970-3411	TXL	22 AWG	0.69-0.75	.027-.030	1.30	.051	1.80	.071	1.60	.063	60	13.5

8.3mm Terminal Progression														
Terminal Plating	Terminal Order No.		Wire Size		Conductor				Insulation				Pull Force Minimum	
					Crimp Height		Crimp Width (Ref)		Crimp Height Maximum		Crimp Width Maximum			
			Wire Type	mm <sup>2</sup> / AWG	mm	In.	mm	In.	mm	In.	mm	In.	N	Lb.
Standard Performance Tin	502306-0111 502306-0121 502306-0211 502306-0221	34803-0111 34803-0121 34803-0211 34803-0221 34863-0211	FLRY-A	0.22	0.62-0.68	.024-.027	1.30	.051	1.50	.059	1.60	.063	35	7.9
Standard Performance Tin	502306-0111 502306-0121 502306-0211 502306-0221	34803-0111 34803-0121 34803-0211 34803-0221 34863-0211	T3ZHID	0.35	0.72-0.78	.028-.031	1.30	.051	1.70	.067	1.60	.063	60	13.5
High Performance Tin	502306-0403 502306-0404 502306-0411 34803-0403	34803-0404 34803-0411 34863-0403 34863-0411	T3ZHID	0.35	0.72-0.78	.028-.031	1.30	.051	1.70	.067	1.60	.063	60	13.5
High Performance Silver	502306-2303 502306-2304	34803-2303 34803-2304	T3ZHID	0.35	0.72-0.78	.028-.031	1.30	.051	1.70	.067	1.60	.063	60	13.5
Standard Performance Tin	502306-0111 502306-0121 502306-0211 502306-0221	34803-0111 34803-0121 34803-0211 34803-0221 34863-0211	A3	0.35	0.72-0.78	.028-.031	1.30	.051	1.95	.077	1.60	.063	60	13.5
High Performance Tin	502306-0403 502306-0404 502306-0411 34803-0403	34803-0404 34803-0411 34863-0403 34863-0411	A3	0.35	0.72-0.78	.028-.031	1.30	.051	1.95	.077	1.60	.063	60	13.5
High Performance Silver	502306-2303 502306-2304	34803-2303 34803-2304	A3	0.35	0.72-0.78	.028-.031	1.30	.051	1.95	.077	1.60	.063	60	13.5
Standard Performance Tin	502306-0111 502306-0121 502306-0211 502306-0221	34803-0111 34803-0121 34803-0211 34803-0221 34863-0211	AVSS	0.30	0.72-0.78	.028-.031	1.30	.051	1.80	.071	1.60	.063	60	13.5
Standard Performance Tin	502306-0111 502306-0121 502306-0211 502306-0221	34803-0111 34803-0121 34803-0211 34803-0221 34863-0211	TXL	22 AWG	0.72-0.78	.028-.031	1.30	.051	1.80	.071	1.60	.063	60	13.5
High Performance Tin	502306-0403 502306-0404 502306-0411 34803-0403	34803-0404 34803-0411 34863-0403 34863-0411	TXL	22 AWG	0.69-0.75	.027-.030	1.30	.051	1.80	.071	1.60	.063	60	13.5

■ **Tool Qualification Notes:**

1. Pull Force should be measured with no influence from the insulation crimp.
2. The above specifications are guidelines to an optimum crimp.

## PARTS LIST

FineAdjust Applicator 63903-2600				
Item	Order No	Engineering No.	Description	Quantity
<b>Perishable Tooling</b>				
	63903-2670	63903-2670	Tool Kit (All "Y" Items)	REF
1	200216-1302	200216-1302	Conductor Punch	1 Y
2	63455-0053	63455-0053	Conductor Anvil	1 Y
3	63454-0148	63454-0148	Insulation Punch	1 Y
4	63456-0048	63456-0048	Insulation Anvil	1 Y
5	63443-0003	63443-0003	Cut-Off Plunger	1 Y
6	63443-0012	63443-0012	Front Plunger Retainer	1 Y
<b>Other Components</b>				
7	11-17-0022	1739-21	Hold Down Spring	1
8	11-18-4083	60707-8	Feed Guide	1
9	11-24-1067	4996-4	Cut-off Plunger Spring	1
10	63443-0009	63443-0009	Scrap Chute	1
11	63443-0024	63443-0024	Key	1
12	63443-0090	63443-0090	Wire Stop	1
13	63443-0093	63443-0093	Shank	1
14	63443-2212	63443-2212	Coarse Spacer (12.00mm)	1
15	63443-2313	63443-2313	Fine Spacer (3.65mm)	1
16	63443-2804	63443-2804	Front Plunger Striker	1
17	63443-6109	63443-6109	Rear Cover	1
18	63443-7103	63443-7103	Terminal Hold Down	1
19	63600-1057	63600-1057	Striker Plunger Spring	1
20	63890-0032	63890-0032	Guide Height Spacer	1
21	63890-0034	63890-0034	Secondary Height Spacer	1
22	63890-0069	63890-0069	Wire Hold-Down Plunger	1
<b>Frame</b>				
23	63800-4901	63800-4901	Top	1
24	63801-3281	63801-3281	Base	1
25	63801-4650	63801-4650	Track	1
<b>Hardware</b>				
26	N/A	N/A	M3 by 6 Long SHCS	2**
27	N/A	N/A	M3 by 6 Long FHCS	1**
28	N/A	N/A	M3 by 8 Long SHCS	1**
29	N/A	N/A	M4 by 6 Long SHCS	2**
30	N/A	N/A	M4 by 12 Long BHCS	2**
31	N/A	N/A	M4 by 50 Long SHCS	2**
32	N/A	N/A	M5 by 12 Long SHCS	1**
33	N/A	N/A	#10-32 by 3/8" Long Flat Point SSS	1**
34	N/A	N/A	#10-32 Hex Jam Nut	1**
** Available from an industrial supply company such as MSC (1-800-645-7270).				

### Assembly Drawing

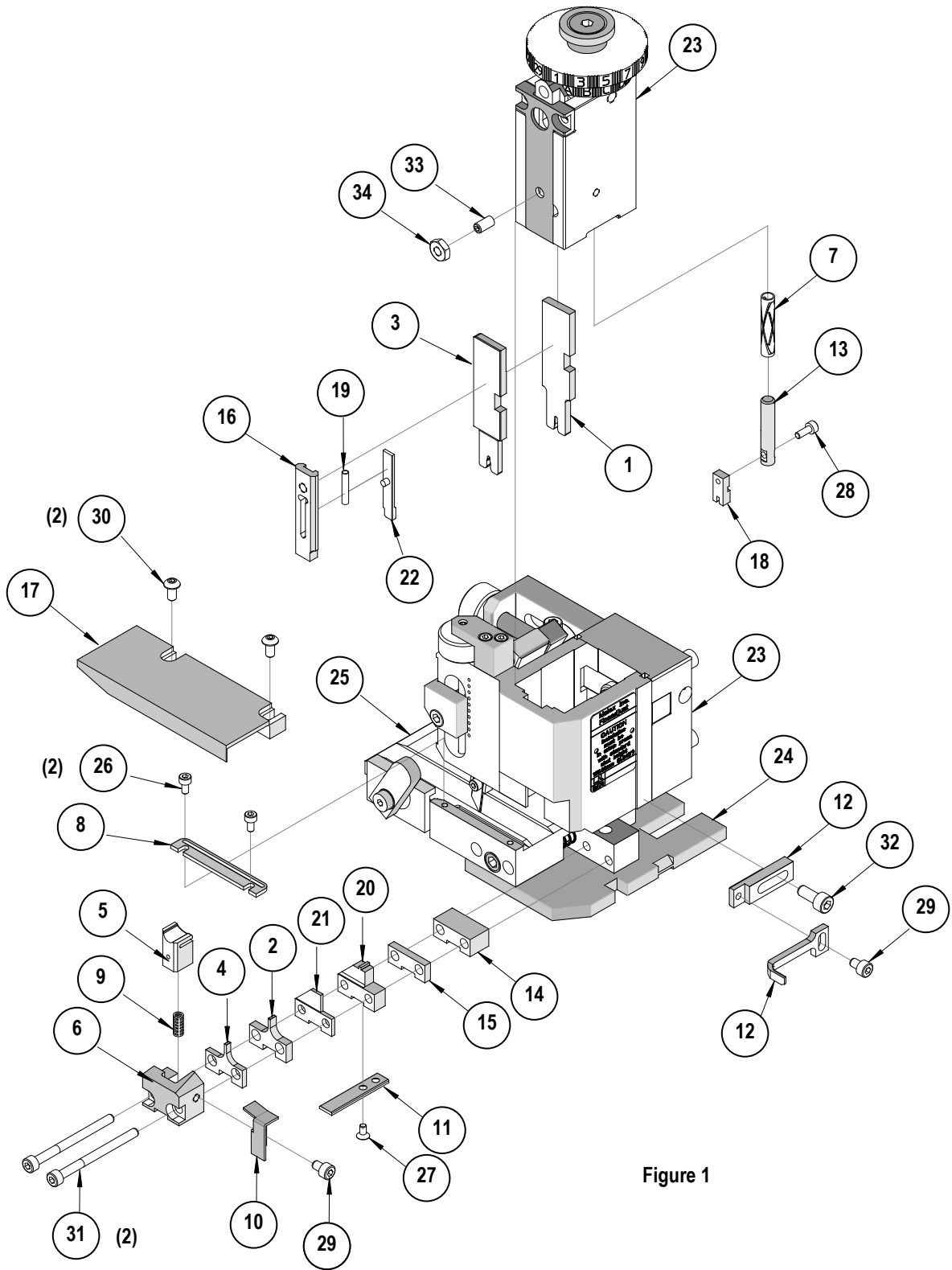

Figure 1

## NOTES

1. Molex recommends an extra perishable tooling kit be maintained at your facility.
2. Verify tooling alignment by manually cycling the press and Applicator before crimping under power. Check that all screws are tight.
3. Slugs, Terminals, Dirt and Oil should be kept clear of work area.
4. Wear safety glasses at all times.
5. For recommended maintenance refer to the FineAdjust Manual.

**CAUTION:** This applicator should only be used in a press with a shut height of 135.80 mm (5.346"). Tooling damage could result at a lower setting.

**CAUTION:** To prevent injury never operate this Applicator without the guards supplied with the press or wire-processing machine in place. Reference the press or wire processing manufacturer's instruction manual.

**CAUTION:** Molex crimp specifications are valid only when used with Molex terminals, applicators, and tooling.

### Application Tooling Support

**Phone:** (402) 458-TOOL (8665)

**E-Mail:** [toolingsupport@molex.com](mailto:toolingsupport@molex.com)

**Website:** [www.molex.com/applicationtooling](http://www.molex.com/applicationtooling)

Molex is a registered trademark of Molex, LLC in the United States of America and may be registered in other countries; all other trademarks listed herein belong to their respective owners.