

PART NUMBER	REVISION	DESCRIPTION	FEED TYPE
2266529-1	D	FINE CRIMP HEIGHT ADJUST	MECHANICAL
2266529-2	E	FINE CRIMP HEIGHT ADJUST	PNEUMATIC
5-2266529-1	D	SEAL STRIPPER CRIMPER TERMINATING UNIT	MECHANICAL
5-2266529-2	E	SEAL STRIPPER CRIMPER TERMINATING UNIT	PNEUMATIC
7-2266529-1	D	MECHANICAL AND CRIMP TOOLING KIT	MECHANICAL
7-2266529-2	E	PNEUMATIC AND CRIMP TOOLING KIT	PNEUMATIC
7-2266529-7	A	CRIMP TOOLING KIT	-

ATLANTIC VERSION TERMINATOR INTERFACE ADAPTER

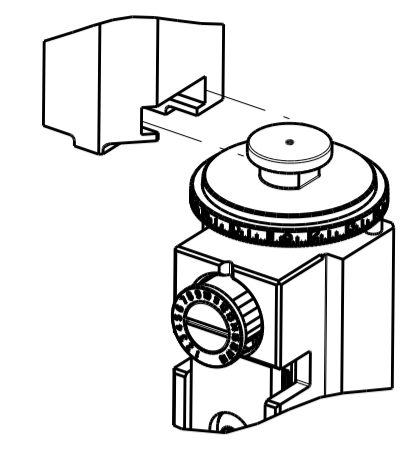

APPLICATOR DATA

CRIMP	SIZE	TYPE
WIRE	1.50 mm [.059]	F
INSUL	1.60 mm [.063]	F

APPLICATOR INSTRUCTIONS 408-35042

TERMINAL DATA: JAE TERMINAL JAE CRIMP SPECIFICATION

TERMINAL NAME: TERMINAL

WIRE STRIP LENGTH	INSULATION DIAMETER RANGE
3.80-4.80 mm [.150-.189 IN]	Ø0.90-1.70 mm [.035-.067 IN]

TERMINAL APPLICATION SPECIFICATION: JABL-1754

TERMINALS APPLIED: 3, 6

TE TERMINAL	JAE TERMINAL	TE TERMINAL	JAE TERMINAL
2113596-1	M34S75C4F1	2318374-1	M34P75C4F1

WIRE SIZE	CRIMP HEIGHT mm [INCH]	CRIMP HEIGHT REFERENCE SETTING
0.35mm2	0.90 +/- 0.05 [.035 +/- .002]	5.2
0.30mm2	0.90 +/- 0.05 [.035 +/- .002]	5.2
0.22mm2	0.85 +/- 0.05 [.033 +/- .002]	5.6

- 1 RECOMMENDED SPARE PARTS
- 2 REFER TO SUPPLIED INSTRUCTION SHEET FOR CLEANING, LUBRICATION AND STORAGE OF APPLICATOR.
- 3 APPLY PART NUMBER 1-23419-5 LOCTITE TO THREADS OF ITEM 180. APPLY PART NUMBER 2-23419-6 LOCTITE TO THREADS OF ITEM 242.
- 4 CRIMP HEIGHT REFERENCE SETTING WAS THE SETTING USED WHEN THE APPLICATOR WAS QUALIFIED AT THE FACTORY. ADJUSTMENT MAY BE NECESSARY WHEN RUNNING APPLICATOR IN THE FIELD.
- 5 WHEN RUNNING SOCKET TERMINAL, USE SET UP SHOWN ON EXPLODED VIEW FOR ITEMS 7 AND 81. WHEN RUNNING PIN TERMINAL, SWITCH POSITION OF ITEMS 7 AND 81 SHOWN ON EXPLODED VIEW.
- 6 TERMINAL LUBRICANT IS RECOMMENDED.
- 7. UNLESS SPECIFIED OTHERWISE TORQUE VALUES SHALL BE USED PER DOCUMENT, 101-35000.

***WARNING**
 ON INSTALLATION, SET WIRE DISC TO CRIMP HEIGHT REFERENCE SETTING FOR LARGEST WIRE SIZE. CRIMP HEIGHT REFERENCE SETTINGS GREATER THAN THE VALUE SHOWN MAY CAUSE DAMAGE TO THE CRIMP TOOLING, REFER TO THE INSTRUCTION SHEET FOR PROPER SETUP AND ADJUSTMENTS.

ATLANTIC VERSION
 Shown on sheets 1 of 4 & 2 of 4
 (Pacific version shown on sheets 3 of 4 & 4 of 4)

LOC	DIST	REV	LTN	DESCRIPTION	DATE	OWN	APPV
A	66	B		ECR-18-003990	15MAR2018	FZ	KZ
		C		ECR-18-007331	14MAY2018	MZ	JDG
		D		ECR-18-012356	06SEP2018	JAH	CT
		E		ECR-19-008911	06JUN2019	FJ	TE

-	-	-	1	1	-	-	1803515-3	RAM ASSEMBLY, SF ATLANTIC	293
-	-	-	1	1	-	-	2-1803583-1	APPLICATOR BASIC ASSEMBLY, SF	292
-	1	-	1	-	1	-	2119641-1	FEED CAM, AIR FEED	248
-	1	1	1	1	1	1	2119082-4	CAM, SNAIL, INSULATION ADJUSTMENT	244
-	1	1	1	1	1	1	2079764-1	WASHER, WAVE SPRING, CREST-TO-CREST	243
-	1	1	1	1	1	1	2119083-1	RETAINER, INSULATION DIAL	242
-	1	1	1	1	1	1	7-18023-7	SCR, SKT HD CAP M3 X 4.0	241
-	-	1	-	1	-	1	2119580-1	MECHANICAL FEED ASSEMBLY	239
-	1	-	1	-	1	-	2844940-1	AIR FEED MODULE	238
-	-	-	1	1	-	-	4-1722335-3	STRIPPER, SIDE FEED	182
-	-	-	1	1	-	-	1-5018030-0	NUT, HEX, REG, RoHS, M3.5	181
-	-	-	1	1	-	-	2-1752354-0	STANDOFF, HOLD-DOWN	180
-	-	-	1	1	-	-	993111-1	PIN, SLOTTED SPRING 3.0 X 20.0	177
-	-	-	1	1	-	-	5-22280-0	SPRING, COMPRESSION	176
-	-	-	1	1	-	-	1752353-3	GUIDE PIN, HOLDDOWN	175
-	-	-	1	1	-	-	1901680-2	GUIDE PIN, HOLDDOWN	174
-	REF	REF	REF	REF	REF	REF	994970-2	COUNTER, MAGNETIC	164
-	1	1	1	1	1	1	2119955-1	ASSY, LUBRICATOR, SIDE FEED	113
-	1	1	1	1	1	1	2844908-1	SCREW, LOCKING	99
-	1	1	1	1	1	1	2844907-1	POST, LOCKING	98
-	1	1	1	1	1	1	455888-5	SPACER, CRIMPER	82
-	1	1	1	1	1	1	1-240641-0	SPACER	81
-	1	1	1	1	1	1	1803607-3	DOCUMENTATION PACKAGE	71
-	1	1	1	1	1	1	2119791-5	DEPRESSOR, WIRE	70
-	1	1	1	1	1	1	2119740-1	TAG, IDENTIFICATION	67
-	2	2	2	2	2	2	2168078-1	SCREW, DRIVE, RH, RoHS, 2 x .188	66
-	1	1	1	1	1	1	2168083-2	SCR, SKT HD CAP, RoHS, M4 X 8.0	60
-	1	1	1	1	1	1	5-18022-5	SCR, HEX HD CAP, M4 X 6.0	59
-	1	1	1	1	1	1	1338685-1	PAWL, FEED	56
-	4	4	4	4	4	4	2168083-3	SCR, SKT HD CAP, RoHS, M4 X 12.0	54
-	2	2	2	2	2	2	2168083-9	SCR, SKT HD CAP, RoHS, M4 X 20	53
-	1	1	1	1	1	1	1803382-6	HOLD DOWN, SPRING LOADED	50
-	1	2	1	2	1	2	18023-9	SCR, SKT HD CAP M4 X 6.0	49
-	-	1	-	1	-	1	2119652-1	FEED CAM, PRE FEED	48
-	-	1	-	1	-	1	2119653-1	FEED CAM, POST FEED	47
-	1	1	-	-	1	1	1803583-9	APPLICATOR BASIC ASSEMBLY, SF	46
-	1	1	-	-	1	1	1803515-1	RAM ASSEMBLY, SF ATLANTIC	44
-	1	1	1	1	1	1	1803602-1	SCR, BHSC, RoHS (M8 X 25)	41
-	1	1	1	1	1	1	2-1752356-0	SUPPORT, TERMINAL	34
-	2	2	2	2	2	2	2079383-5	SCR, BHSC, RoHS (M4 X 20)	33
-	2	2	2	2	2	2	2-2844962-4	SPACER, CYLINDRICAL, STRIP GUIDE	30
-	1	1	1	1	1	1	2844992-1	ASSEMBLY, STRIP GUIDE	29
-	1	1	1	1	1	1	1320928-2	STRIP GUIDE	24
-	1	1	-	-	1	1	2168083-2	SCR, SKT HD CAP, RoHS, M4 X 8.0	21
-	2	2	1	1	2	2	1-18028-2	WASHER, FLAT, REG M4	20
-	1	1	-	-	1	1	2119533-1	STRIPPER, SIDE FEED	19
-	1	1	1	1	1	1	2119806-1	INSERT, SHEAR	13
-	1	1	1	1	1	1	3-22280-3	SPRING, COMPRESSION	12
-	1	1	1	1	1	1	1-356885-4	STOP, SHEAR	11
-	1	1	1	1	1	1	2119805-1	SHEAR HOLDER, FRONT	10
-	1	1	1	1	1	1	1803095-3	FLOATING SHEAR, FRONT	9
1	2	2	1	1	1	1	3-1803057-4	ANVIL, COMBINATION	8
-	1	1	1	1	1	1	2-240641-5	SPACER	7
-	-	-	-	-	-	-	-	-	6
-	1	1	1	1	1	1	2119757-4	DEPRESSOR, SHEAR	5
-	1	1	1	1	1	1	238011-9	BLOCK, CRIMPER SPACER	4
1	2	2	1	1	1	1	2-1803017-4	CRIMPER, INSULATION F	3
-	-	-	-	-	-	-	-	-	2
1	2	2	1	1	1	1	1803188-6	CRIMPER, WIRE	1

ITEM NO	PART NO	DESCRIPTION
-77	-72	-71
-52	-51	-2
-1		

OWN	H. HUANG	20OCT2014
CHK	L. ZHANG	20OCT2014
APPV	H. GUO	20OCT2014

TE Connectivity
 Harrisburg, PA 17105-3608

NAME: Ocean Side Feed Applicator

SIZE: A1 | 00779 | C=2266529

Customer Accessible Production Drawing | SCALE: 1:2 | SHEET: 1 OF 4 | REV: E

LOC	DIST	REV	DATE	BY	APP'D
A	66				
REVISIONS			DESCRIPTION	DATE	BY
			SEE SHEET 1		

FEED TYPE MECHANICAL

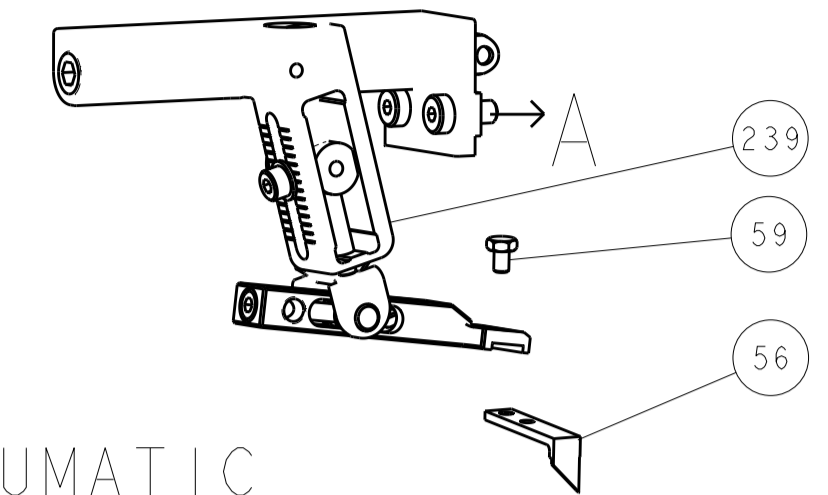

PNEUMATIC

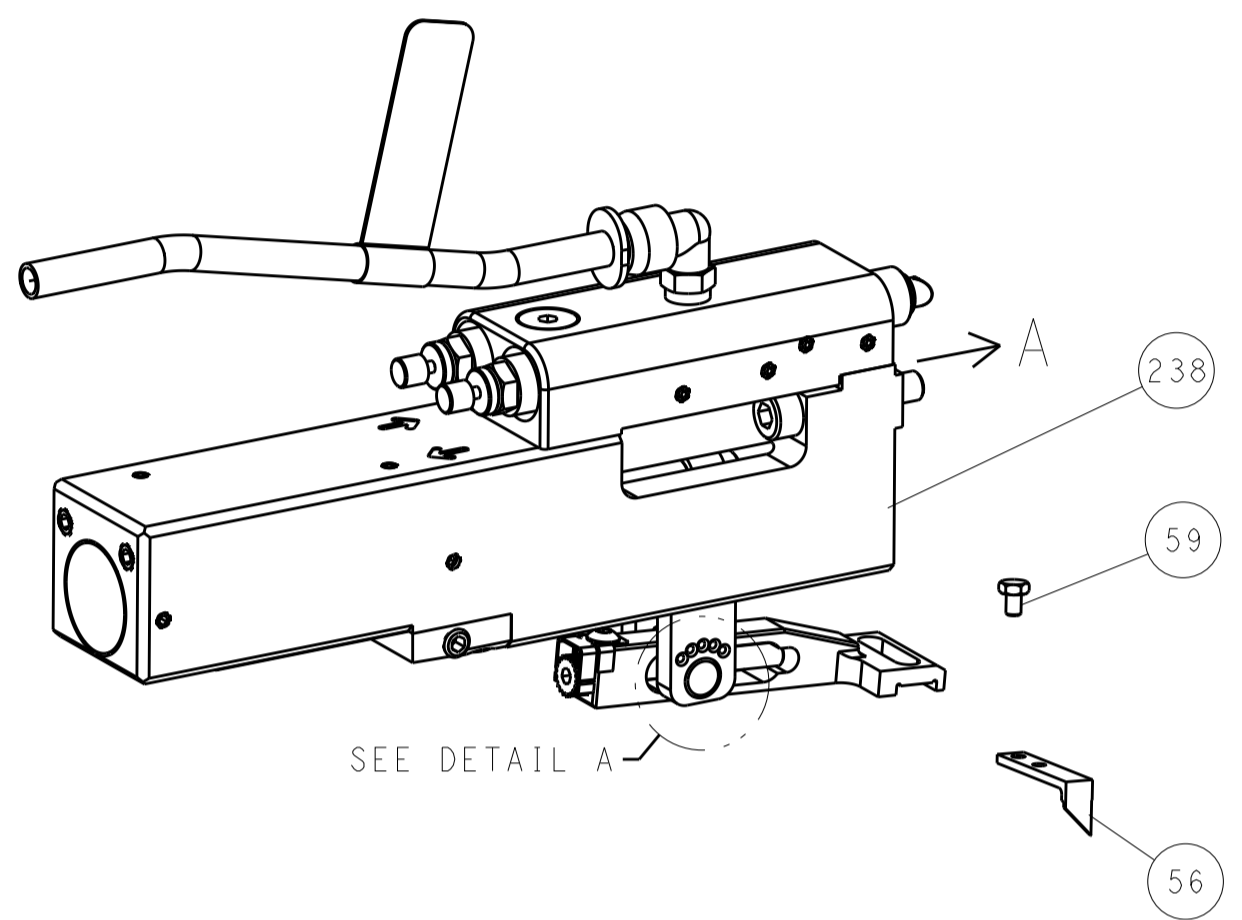

FEED SPRING SETTING POSITION (SHOWN FROM REAR SIDE)

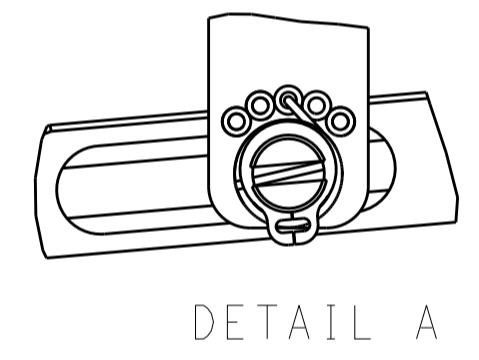

DETAIL A

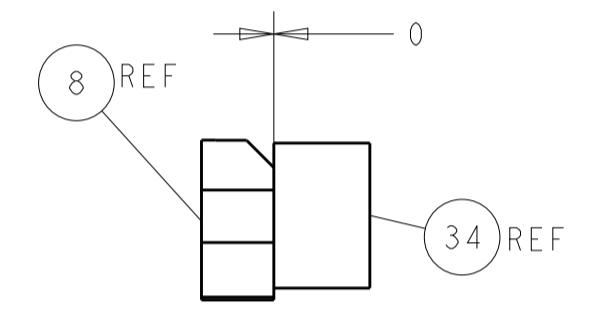
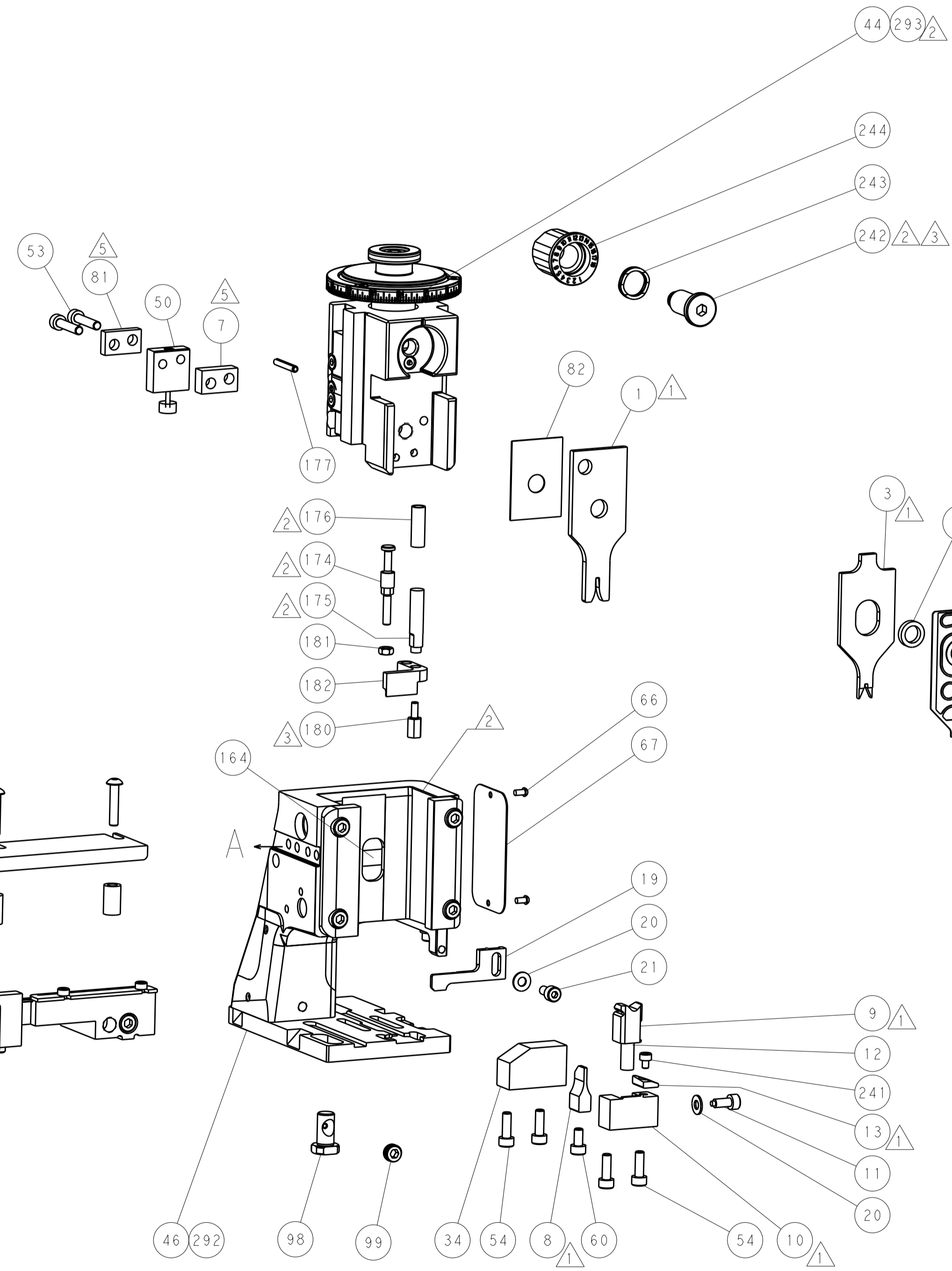

TERMINAL SUPPORT LOCATION

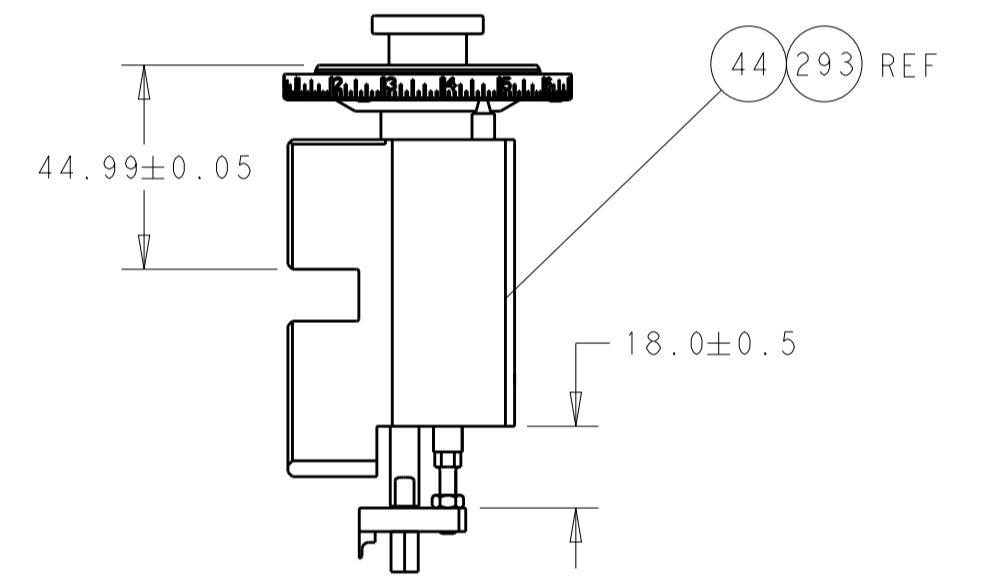

RAM AND HOLDDOWN SET-UP

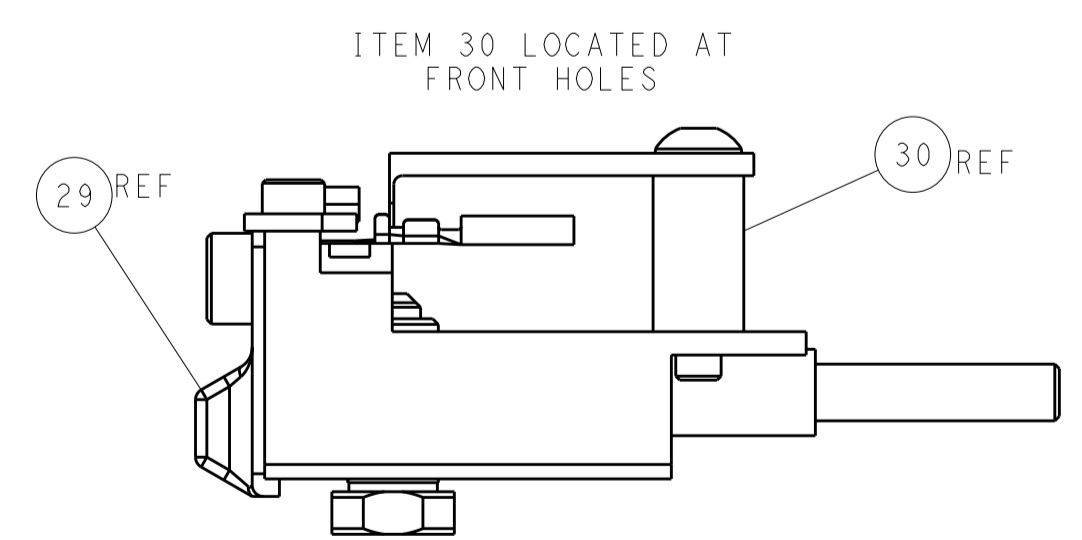

ITEM 30 LOCATED AT FRONT HOLES

CAM POSITIONS

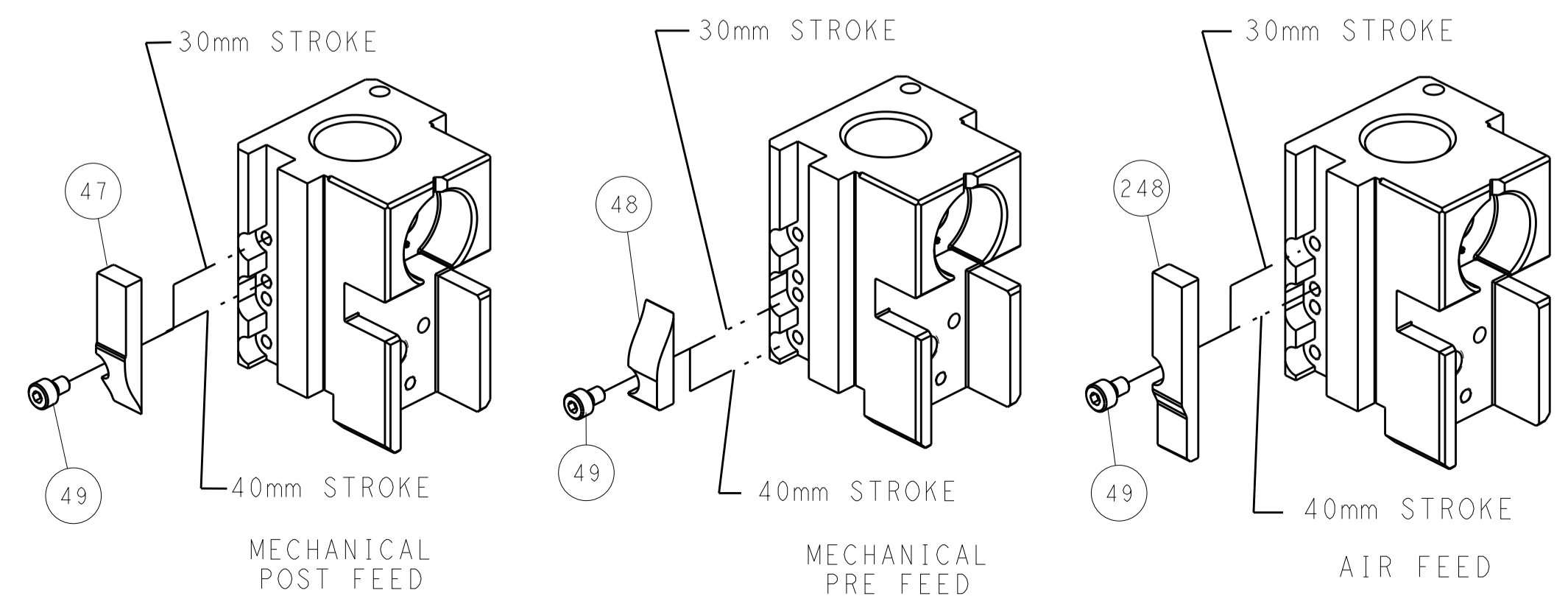

ATLANTIC VERSION
 Shown on sheets 1 of 4 & 2 of 4
 (Pacific version shown on sheets 3 of 4 & 4 of 4)

DIMENSIONS:		TOLERANCES UNLESS OTHERWISE SPECIFIED:		DWN H. HUANG 20OCT2014		TE Connectivity	
mm	0 PLC	±		CHK L. ZHANG 20OCT2014	NAME		Harrisburg, PA 17105-3608
	1 PLC	±		APP'D JJ. GUO 20OCT2014	PRODUCT SPEC		
	2 PLC	±			APPLICATION SPEC		
	3 PLC	±			SIZE		CAGE CODE DRAWING NO
	4 PLC	±			WEIGHT		RESTRICTED TO
	ANGLES	±			MATERIAL		
					FINISH		
				Customer Accessible Production Drawing		SCALE 1:2 SHEET 2 OF 4 REV E	

THIS DRAWING IS UNPUBLISHED.	RELEASED FOR PUBLICATION		
COPYRIGHT 20 BY TYCO ELECTRONICS CORPORATION. ALL RIGHTS RESERVED.			
PART NUMBER	REVISION	DESCRIPTION	FEED TYPE
2-2266529-1	D	FINE CRIMP HEIGHT ADJUST	MECHANICAL
2-2266529-2	E	FINE CRIMP HEIGHT ADJUST	PNEUMATIC
7-2266529-7	A	CRIMP TOOLING KIT	-

PACIFIC VERSION TERMINATOR
INTERFACE ADAPTER



APPLICATOR DATA		
CRIMP	SIZE	TYPE
WIRE	1.50 mm [.059]	F
INSUL	1.60 mm [.063]	F
APPLICATOR INSTRUCTIONS 408-35042		

TERMINAL DATA: JAE TERMINAL		JAE CRIMP SPECIFICATION	
TERMINAL NAME: TERMINAL			
WIRE STRIP LENGTH 3.80-4.80 mm [1.50-.189 IN]		INSULATION DIAMETER RANGE Ø0.90-1.70 mm [.035-.067 IN]	
TERMINAL APPLICATION SPECIFICATION JAHL-1754			
TERMINALS APPLIED			
TE TERMINAL	JAE TERMINAL	TE TERMINAL	JAE TERMINAL
2113596-1	M34S75C4F1	2318374-1	M34P75C4F1

WIRE SIZE	CRIMP HEIGHT mm [INCH]	CRIMP HEIGHT REFERENCE SETTING
0.35mm2	0.90+/-0.05 [.035+/-0.002]	5.2
0.30mm2	0.90+/-0.05 [.035+/-0.002]	5.2
0.22mm2	0.85+/-0.05 [.033+/-0.002]	5.6



- 1. RECOMMENDED SPARE PARTS
- 2. REFER TO SUPPLIED INSTRUCTION SHEET FOR CLEANING, LUBRICATION AND STORAGE OF APPLICATOR.
- 3. APPLY PART NUMBER 2-23419-6 LOCTITE TO THREADS OF ITEM 242.
- 4. CRIMP HEIGHT REFERENCE SETTING WAS THE SETTING USED WHEN THE APPLICATOR WAS QUALIFIED AT THE FACTORY. ADJUSTMENT MAY BE NECESSARY WHEN RUNNING APPLICATOR IN THE FIELD.
- 5. WHEN RUNNING SOCKET TERMINAL, USE SET UP SHOWN ON EXPLODED VIEW FOR ITEMS 7 AND 81. WHEN RUNNING PIN TERMINAL, SWITCH POSITION OF ITEMS 7 AND 81 SHOWN ON EXPLODED VIEW.
- 6. TERMINAL LUBRICANT IS RECOMMENDED.
- 7. UNLESS SPECIFIED OTHERWISE TORQUE VALUES SHALL BE USED PER DOCUMENT, 101-35000.

***WARNING**
ON INSTALLATION, SET WIRE DISC TO CRIMP HEIGHT REFERENCE SETTING FOR LARGEST WIRE SIZE. CRIMP HEIGHT REFERENCE SETTINGS GREATER THAN THE VALUE SHOWN MAY CAUSE DAMAGE TO THE CRIMP TOOLING, REFER TO THE INSTRUCTION SHEET FOR PROPER SETUP AND ADJUSTMENTS.

PACIFIC VERSION
Shown on sheets 3 of 4 & 4 of 4
(Atlantic version shown on sheets 1 of 4 & 2 of 4)

LOC	DIST	REVISIONS			
A	66	REV	DATE	BY	APPD
		-	SEE SHEET 1	-	-

-	1	1	2119082-4	CAM, SNAIL, INSULATION ADJUSTMENT	244
-	1	1	2079764-1	WASHER, WAVE SPRING, CREST-TO-CREST	243
-	1	1	2119083-1	RETAINER, INSULATION DIAL	242
-	1	1	7-18023-7	SCR, SKT HD CAP M3 X 4.0	241
-	-	1	2119580-1	MECHANICAL FEED ASSEMBLY	239
-	1	-	2844940-1	AIR FEED MODULE	238
-	REF	REF	994970-2	COUNTER, MAGNETIC	164
-	1	-	2119641-2	FEED CAM, AIR FEED	151
-	1	1	2168083-8	SCR, SKT HD CAP, RoHS, M4 X 16	144
-	4	4	2168083-9	SCR, SKT HD CAP, RoHS, M4 X 20	143
-	-	1	2119653-2	FEED CAM, POST FEED	142
-	1	1	1-1803583-0	APPLICATOR BASIC ASSEMBLY, SF	141
-	1	1	1803516-1	RAM ASSEMBLY, SF PACIFIC	140
-	1	1	2119955-1	ASSY, LUBRICATOR, SIDE FEED	113
-	1	1	2844908-1	SCREW, LOCKING	99
-	1	1	2844907-1	POST, LOCKING	98
-	1	1	455888-5	SPACER, CRIMPER	82
-	1	1	1-240641-0	SPACER	81
-	1	1	1803607-3	DOCUMENTATION PACKAGE	71
-	1	1	2119791-5	DEPRESSOR, WIRE	70
-	1	1	2119740-1	TAG, IDENTIFICATION	67
-	2	2	2168078-1	SCREW, DRIVE, RH, RoHS, 2 x .188	66
-	1	1	5-18022-5	SCR, HEX HD CAP, M4 X 6.0	59
-	1	1	1338685-1	PAWL, FEED	56
-	2	2	2168083-9	SCR, SKT HD CAP, RoHS, M4 X 20	53
-	1	1	1803382-6	HOLD DOWN, SPRING LOADED	50
-	1	2	18023-9	SCR, SKT HD CAP M4 X 6.0	49
-	-	1	2119652-1	FEED CAM, PRE FEED	48
-	1	1	1803602-1	SCR, BHSC, RoHS (M8 X 25)	41
-	1	1	2-1752356-0	SUPPORT, TERMINAL	34
-	2	2	2079383-5	SCR, BHSC, RoHS (M4 X 20)	33
-	2	2	2-2844962-4	SPACER, CYLINDRICAL, STRIP GUIDE	30
-	1	1	2844992-1	ASSEMBLY, STRIP GUIDE	29
-	1	1	1320928-2	STRIP GUIDE	24
-	1	1	2168083-2	SCR, SKT HD CAP, RoHS, M4 X 8.0	21
-	2	2	1-18028-2	WASHER, FLAT, REG M4	20
-	1	1	2119533-1	STRIPPER, SIDE FEED	19
-	1	1	2119806-1	INSERT, SHEAR	13
-	1	1	3-22280-3	SPRING, COMPRESSION	12
-	1	1	1-356885-4	STOP, SHEAR	11
-	1	1	2119805-1	SHEAR HOLDER, FRONT	10
-	1	1	1803095-3	FLOATING SHEAR, FRONT	9
-	1	1	3-1803057-4	ANVIL, COMBINATION	8
-	1	1	2-240641-5	SPACER	7
-	-	-	-	-	6
-	1	1	2119757-4	DEPRESSOR, SHEAR	5
-	1	1	238011-9	BLOCK, CRIMPER SPACER	4
-	1	1	2-1803017-4	CRIMPER, INSULATION F	3
-	-	-	-	-	2
-	1	1	1803188-6	CRIMPER, WIRE	1
-77	-22	-21	PART NO	DESCRIPTION	ITEM NO

DIMENSIONS: mm		TOLERANCES UNLESS OTHERWISE SPECIFIED:		DWG CH CHK L.ZHANG 20OCT2014		DATE 20OCT2014		NAME Ocean Side Feed Applicator	
0 PLC ±		1 PLC ±		APVD J. GUO 20OCT2014		PRODUCT SPEC		SIZE A1	
2 PLC ±		3 PLC ±		APPLICATION SPEC		WEIGHT		SCALE 1:2	
4 PLC ±		ANGLES		FINISH		REVISIONS		SHEET 3 OF 4	
MATERIAL		FINISH		WEIGHT		REVISIONS		REV E	
				Customer Accessible Production Drawing		SCALE 1:2		SHEET 3 OF 4	

LOC		DIST		REVISIONS			
P	LTN	DESCRIPTION	DATE	DMN	APVD		
A	66	SEE SHEET 1					

FEED TYPE MECHANICAL

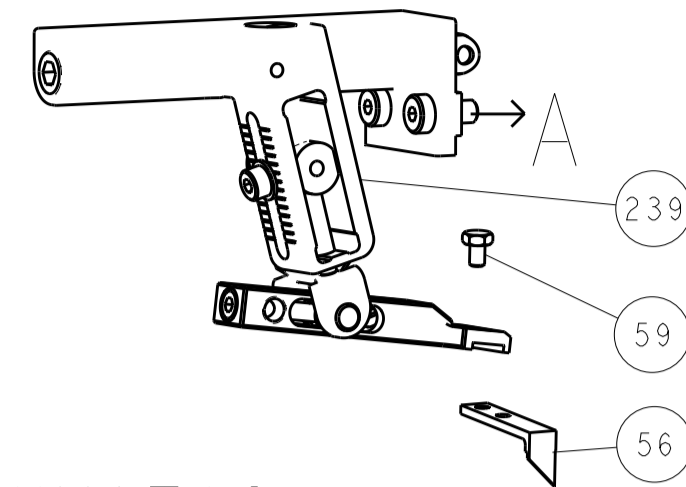

PNEUMATIC

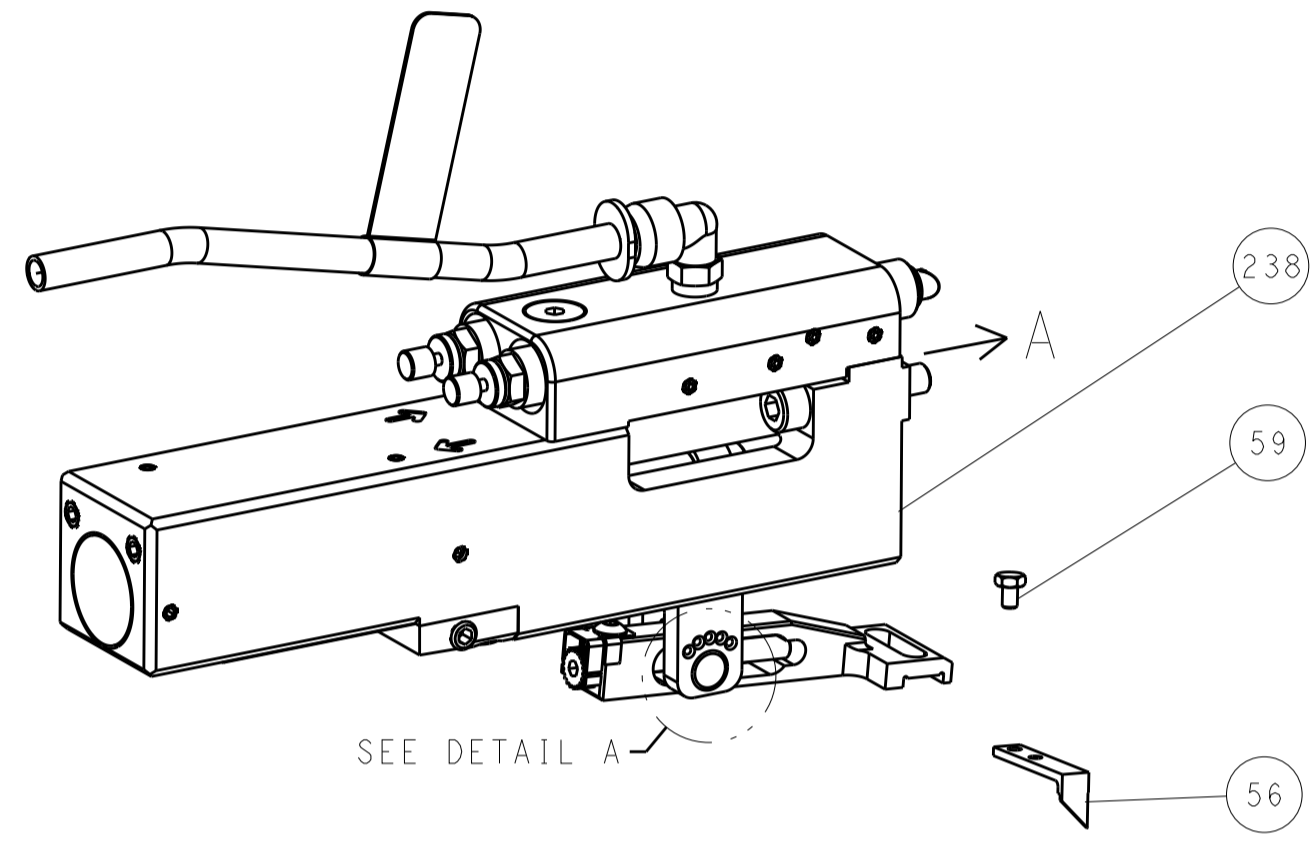

FEED SPRING SETTING POSITION (SHOWN FROM REAR SIDE)

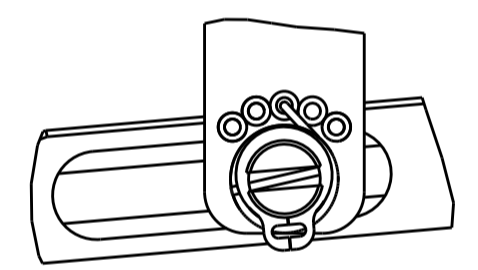

DETAIL A

CAM POSITIONS

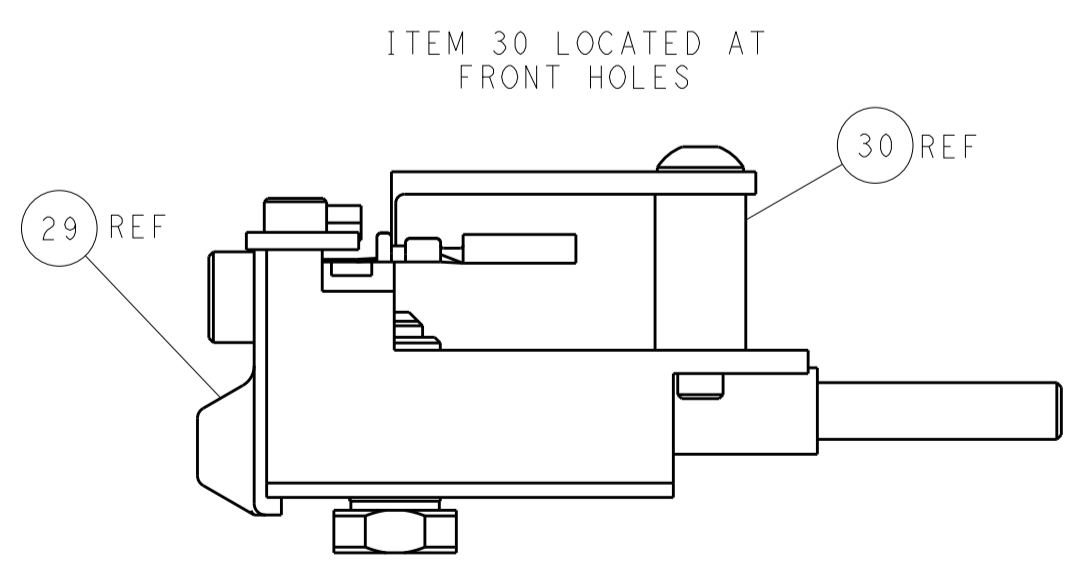
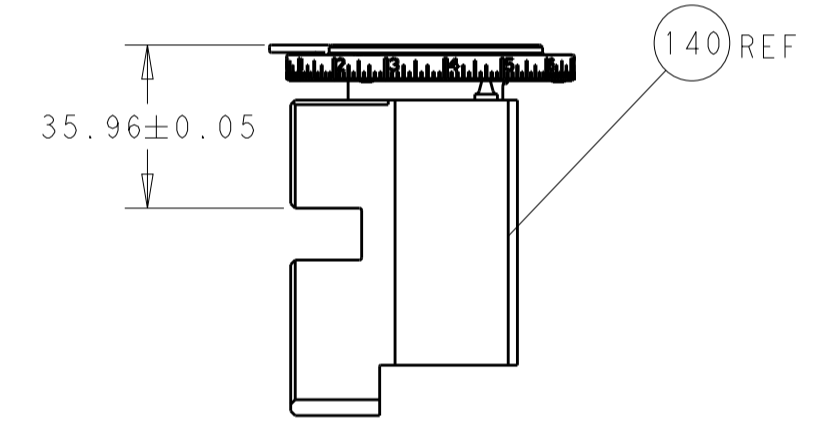
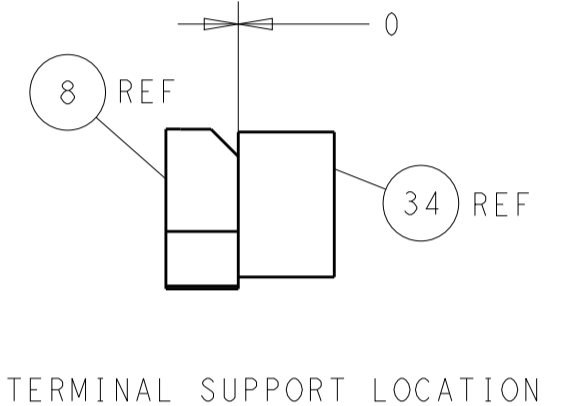
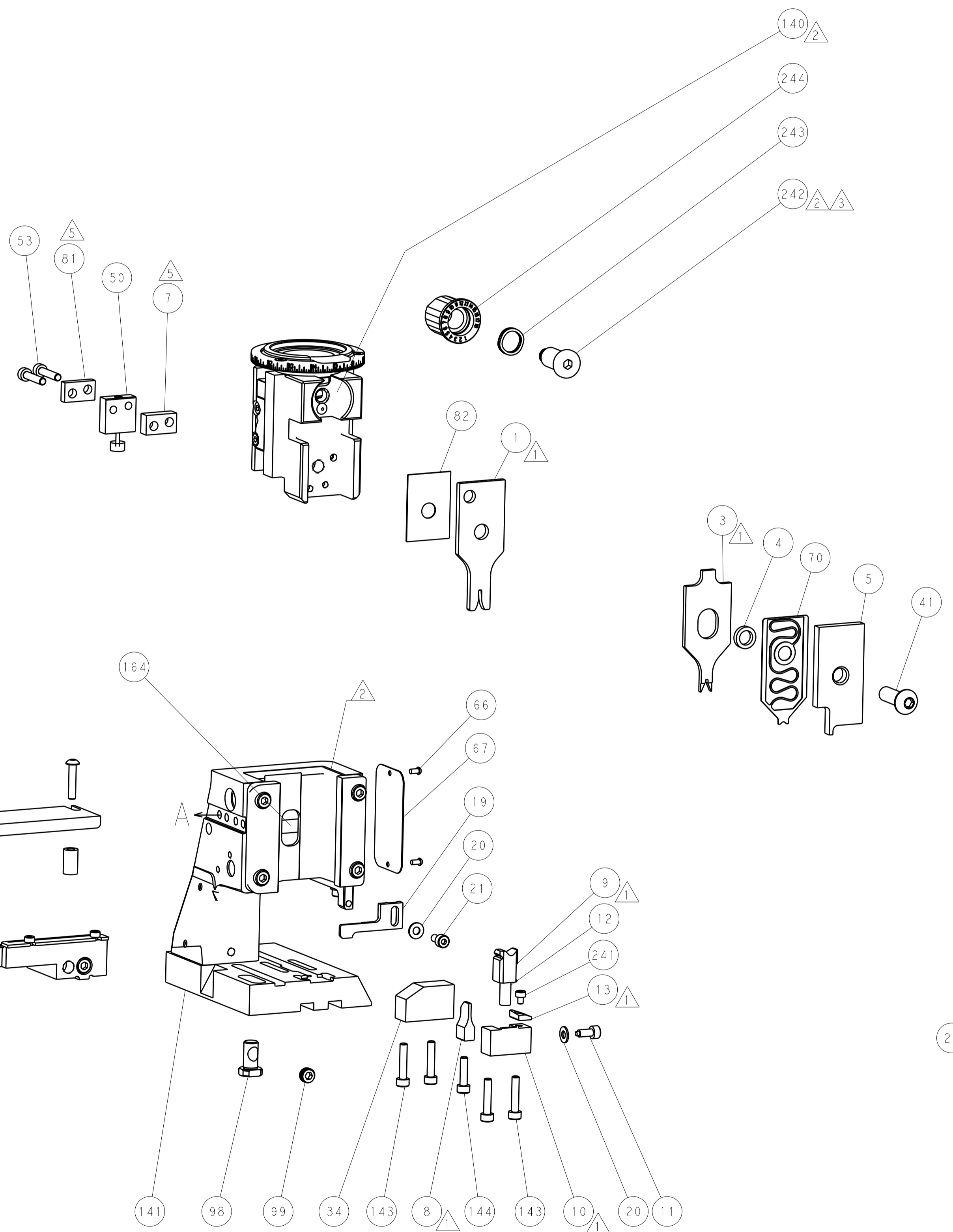
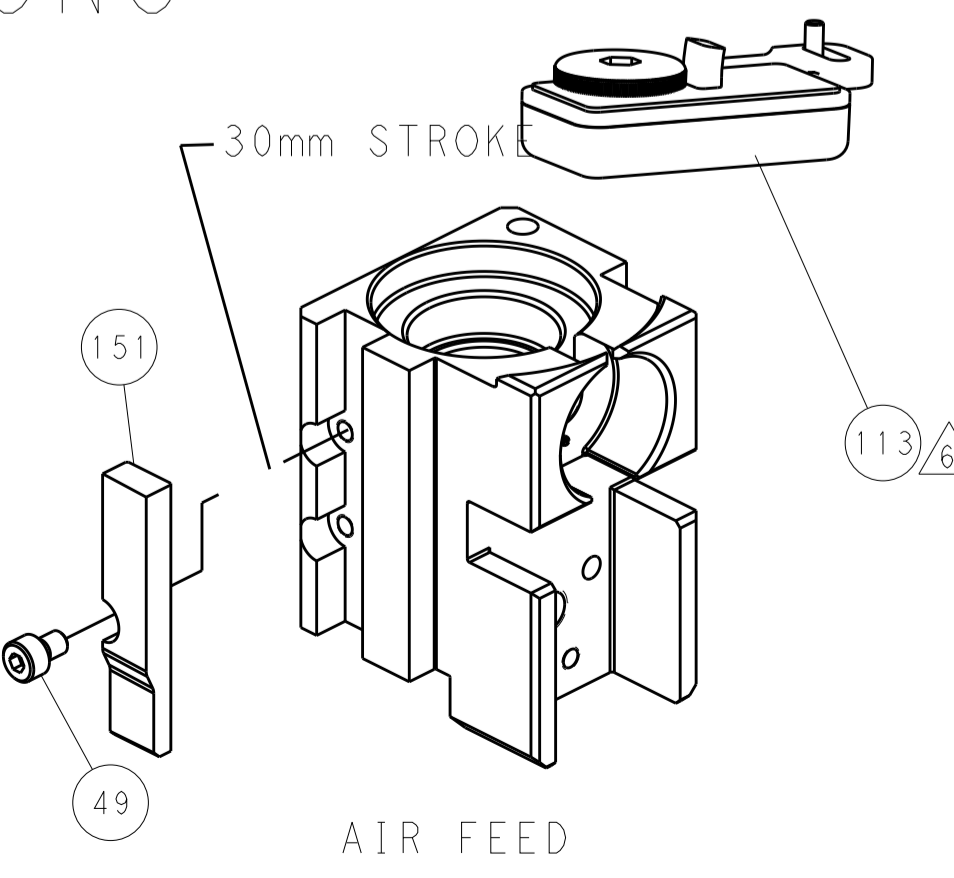
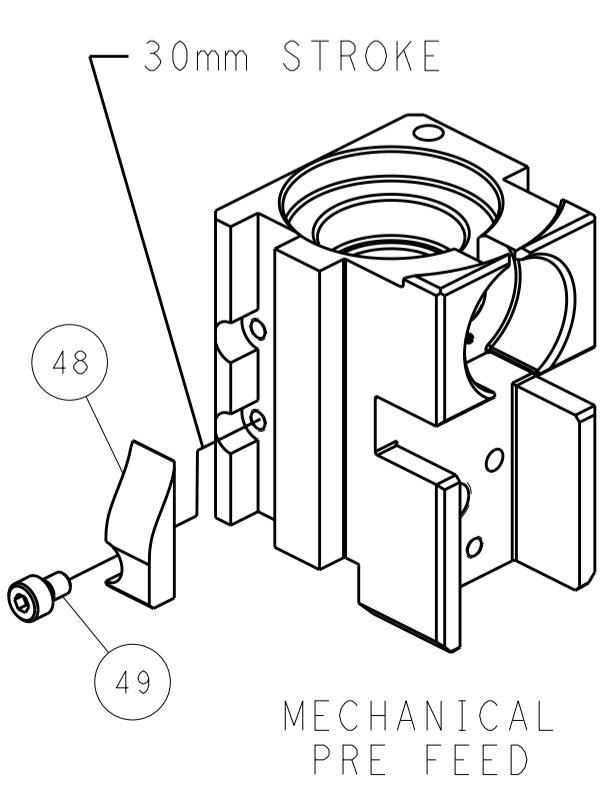
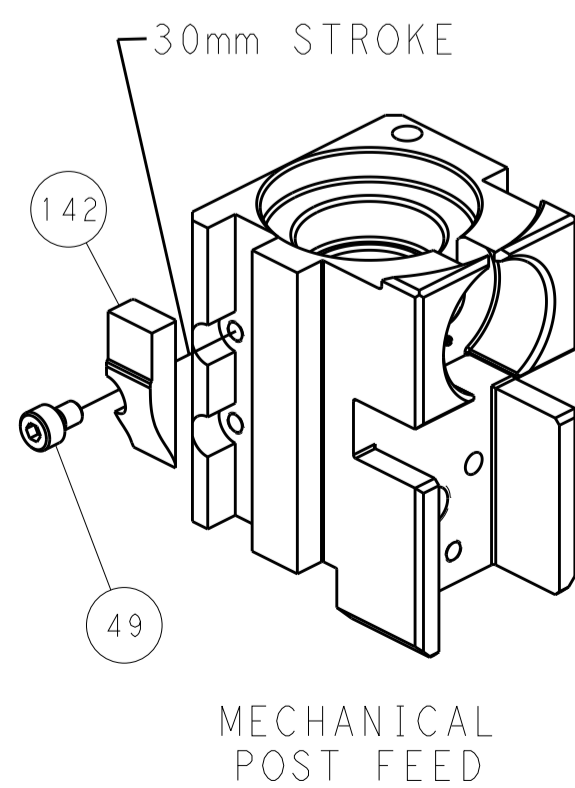

PACIFIC VERSION
 Shown on sheets 3 of 4 & 4 of 4
 (Atlantic version shown on sheets 1 of 4 & 2 of 4)

<small>THE INFORMATION CONTAINED HEREIN IS UNCLASSIFIED EXCEPT WHERE SHOWN OTHERWISE. IT IS SUBJECT TO CHANGE WITHOUT NOTICE AND WITHOUT LIABILITY. REVISIONS SHOULD BE CONTACTED FOR THE LATEST POSITION.</small>		DWN: H. HUANG 20OCT2014 CHK: L. ZHANG 20OCT2014 APVD: H. GUO 20OCT2014	TE Connectivity Harrisburg, PA 17105-3608
DIMENSIONS: mm TOLERANCES UNLESS OTHERWISE SPECIFIED: 0 PLC ± 1 PLC ± 2 PLC ± 3 PLC ± 4 PLC ± ANGLES ±		NAME: Ocean Side Feed Applicator PRODUCT SPEC: APPLICATION SPEC: SIZE: A1 CAGE CODE: 00779 DRAWING NO: 2266529	RESTRICTED TO: SCALE: 1:2 SHEET: 4 OF 4 REV: E
MATERIAL: FINISH:		WEIGHT: Customer Accessible Production Drawing	SHEETS 1 & 2 ARE NOT REQUIRED FOR PACIFIC VERSION