

NOTES:

- MATERIAL : HOUSING & BASEPLATE.  
 - LCP, GLASS FILLED, UL94-V0, BLACK.  
 LATCH.  
 - HIGH TEMP. NYLON, GLASS FILLED, UL94-V0, NATURAL (OFF WHITE).  
 TERMINALS & FORKLOCK - COPPER ALLOY.
  - PLATING : CONTACT AREA - SEE TABLE ON SHEET 5.  
 SOLDERTAIL - SEE TABLE ON SHEET 5.
  - CARD SLOT ACCEPTS 1.27+/-0.10MM MODULE THICKNESS (MEASURED OVER PC PADS).
  - REFER TO PRODUCT SPECIFICATION, PS-87919-001 FOR PERFORMANCE SPECIFICATION.
  - RECOMMENDED MODULE CARD LAYOUT SHALL BE AS PER JEDEC MO-237.
  - PRODUCT SHALL BE PACKED IN TRAY. PLS REFER TO SHEET 3.
- MOLEX LOGO, DATE & PART NUMBER INDICATED ON HOUSING.

ADDED OPTION EC NO: S2010-0393 DRWN:LCYH 2009/11/16 CH'KD:CGTAN 2009/11/16 APPR:SHLENI 2009/11/17 A7	DESCRIPTION REV	QUALITY SYMBOLS	GENERAL TOLERANCES (UNLESS SPECIFIED) <table border="1"> <thead> <tr> <th></th> <th>mm</th> <th>INCH</th> </tr> </thead> <tbody> <tr> <td>4 PLACES</td> <td>± ---</td> <td>± ---</td> </tr> <tr> <td>3 PLACES</td> <td>± ---</td> <td>± ---</td> </tr> <tr> <td>2 PLACES</td> <td>± 0.25</td> <td>± ---</td> </tr> <tr> <td>1 PLACE</td> <td>± ---</td> <td>± ---</td> </tr> <tr> <td colspan="3">ANGULAR ± 5 °</td> </tr> </tbody> </table>		mm	INCH	4 PLACES	± ---	± ---	3 PLACES	± ---	± ---	2 PLACES	± 0.25	± ---	1 PLACE	± ---	± ---	ANGULAR ± 5 °			DIMENSION STYLE MM ONLY	SCALE NTS	DESIGN UNITS METRIC	THIRD ANGLE PROJECTION DDR2 DIMM, 1.00MM PITCH 240 CKTS, 25 DEG. REVERSE ANGLE MOLEX MOLEX INCORPORATED SD-87919-001
				mm	INCH																				
		4 PLACES		± ---	± ---																				
		3 PLACES		± ---	± ---																				
2 PLACES	± 0.25	± ---																							
1 PLACE	± ---	± ---																							
ANGULAR ± 5 °																									
<table border="1"> <tr> <td>DRAWN BY</td> <td>DATE</td> </tr> <tr> <td>JTAN</td> <td>2004/05/26</td> </tr> <tr> <td>CHECKED BY</td> <td>DATE</td> </tr> <tr> <td>MLONG</td> <td>2004/06/11</td> </tr> <tr> <td>APPROVED BY</td> <td>DATE</td> </tr> <tr> <td>GGLEE</td> <td>2004/06/11</td> </tr> </table>	DRAWN BY	DATE	JTAN	2004/05/26	CHECKED BY	DATE	MLONG	2004/06/11	APPROVED BY	DATE	GGLEE	2004/06/11	TITLE												
DRAWN BY	DATE																								
JTAN	2004/05/26																								
CHECKED BY	DATE																								
MLONG	2004/06/11																								
APPROVED BY	DATE																								
GGLEE	2004/06/11																								
MATERIAL NO.	DOCUMENT NO.	SHEET NO.																							
SEE TABLE	SD-87919-001	1 OF 6																							

THIS DRAWING CONTAINS INFORMATION THAT IS PROPRIETARY TO MOLEX INCORPORATED AND SHOULD NOT BE USED WITHOUT WRITTEN PERMISSION

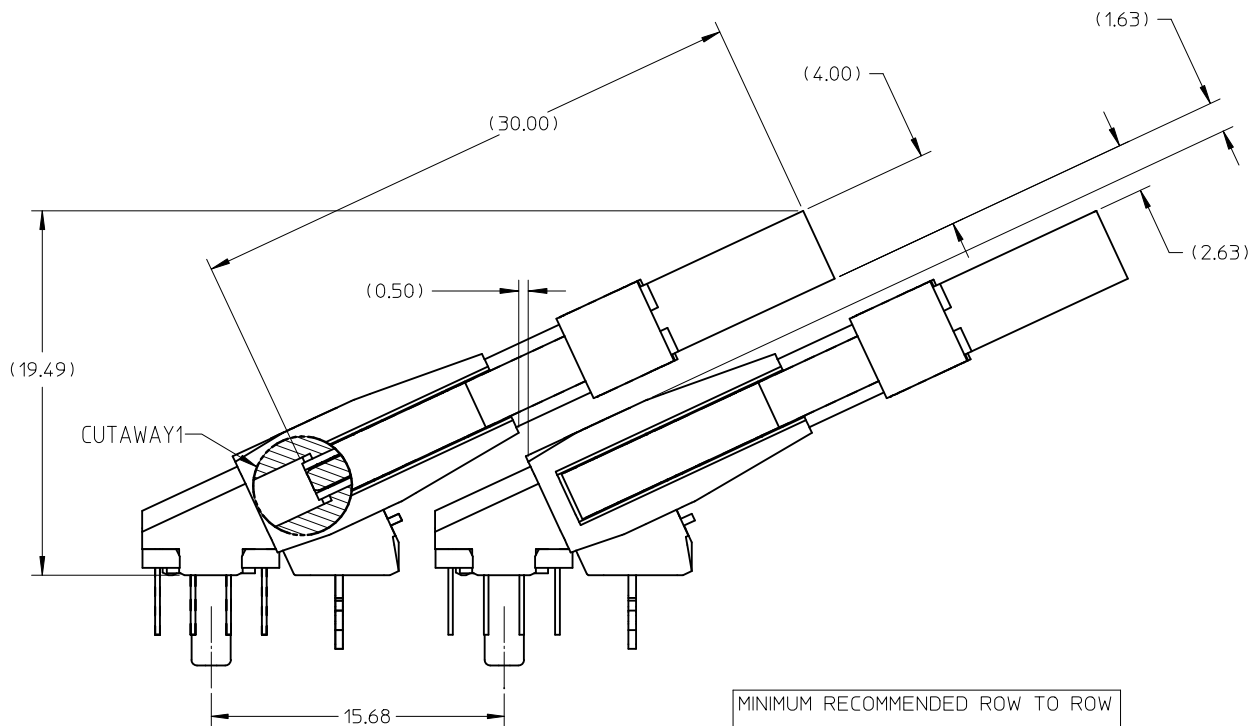
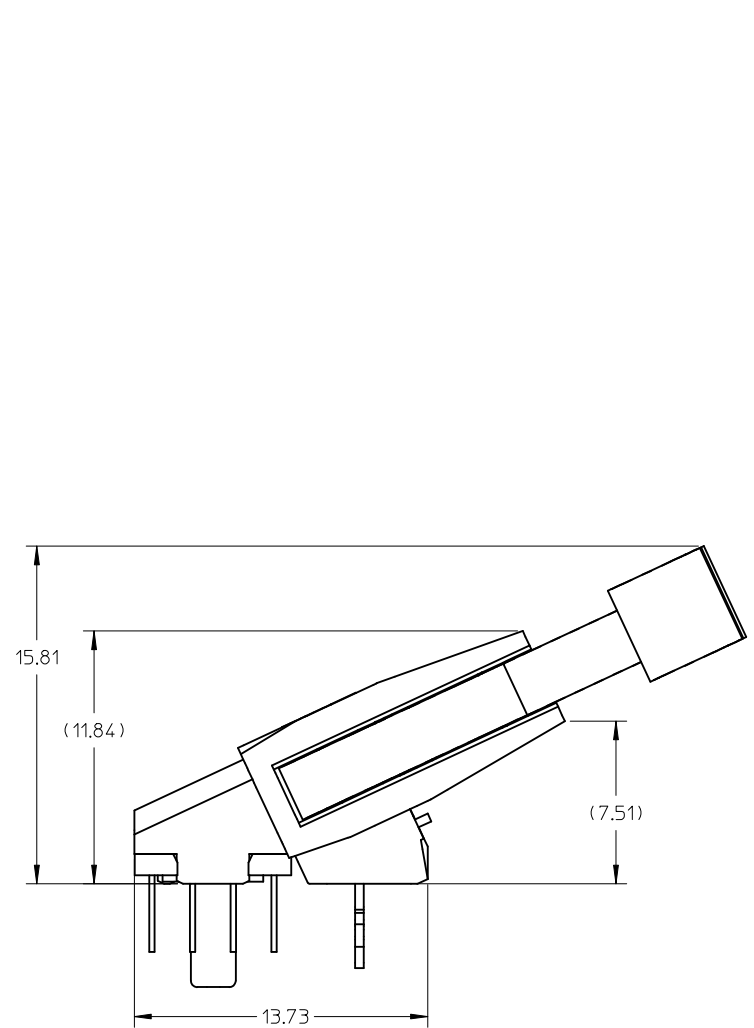

MINIMUM RECOMMENDED ROW TO ROW SPACING WHEN USING 4.00MM THICK MODULE.

ADDED OPTION EC NO: S2010-0393 DRWN:CCTEH 2009/11/16 CHKD:CGTAN 2009/11/16 APPR:SHLENI 2009/11/17	QUALITY SYMBOLS $F_A=0$ $F_E=0$ $F_P=0$	GENERAL TOLERANCES (UNLESS SPECIFIED)		DIMENSION STYLE <b>MM ONLY</b>		SCALE NTS	DESIGN UNITS METRIC	THIRD ANGLE PROJECTION	
		mm	INCH	DRAWN BY JTAN	DATE 2004/05/26	TITLE DDR2 DIMM, 1.00MM PITCH 240 CKTS, 25 DEG. REVERSE ANGLE			
		4 PLACES ± ---	± ---	CHECKED BY MLONG	DATE 2004/06/11	MOLEX INCORPORATED			
		3 PLACES ± ---	± ---	APPROVED BY GGLEE	DATE 2004/06/11	MATERIAL NO. SEE TABLE	DOCUMENT NO. SD-87919-001	SHEET NO. 2 OF 6	
1 PLACE ± ---    ± --- ANGULAR ± 5 °		DRAFT WHERE APPLICABLE MUST REMAIN WITHIN DIMENSIONS		SIZE A3		THIS DRAWING CONTAINS INFORMATION THAT IS PROPRIETARY TO MOLEX INCORPORATED AND SHOULD NOT BE USED WITHOUT WRITTEN PERMISSION			

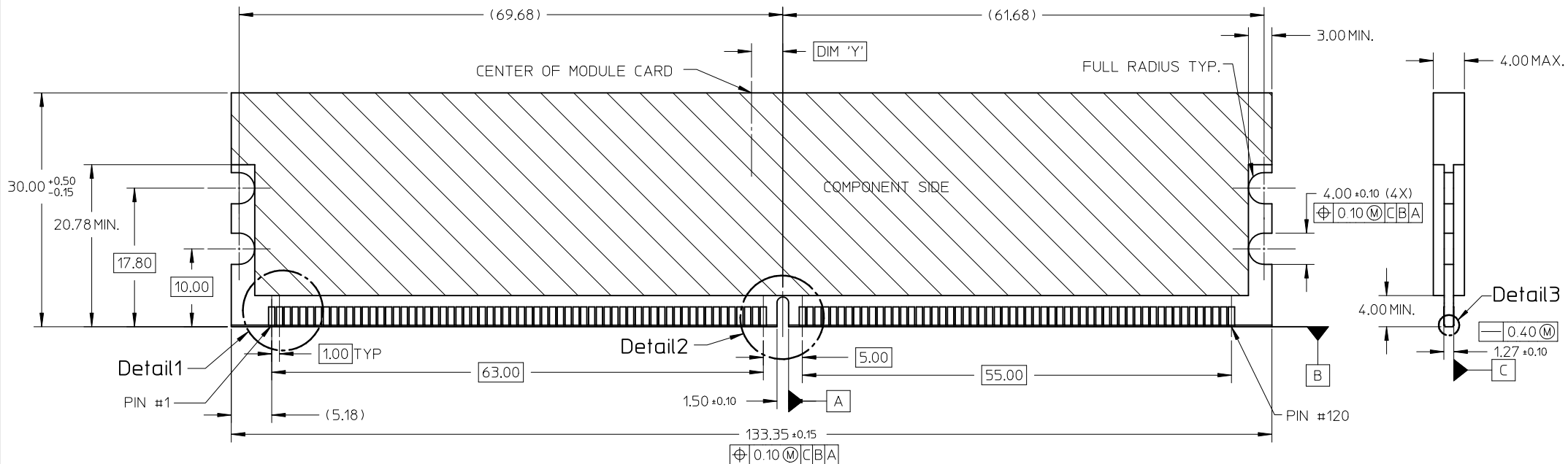

RECOMMENDED MODULE LAYOUT

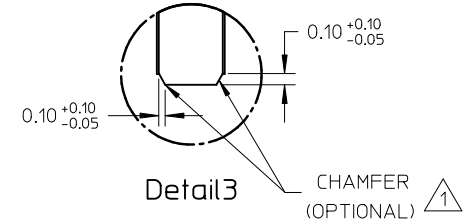
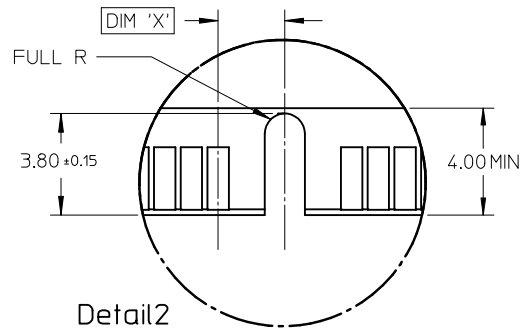
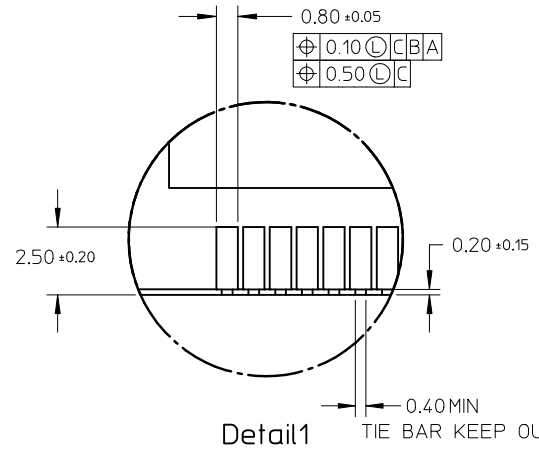

KEY LOCATION	VOLTAGE	DIM 'X'	DIM 'Y'
CENTER	1.8V	2.50	4.00

NOTES :  
 1 MODULE CARD USED IN PRODUCT TESTING ARE CHAMFERED.

ADDED OPTION EC NO: S2010-0393 DRWN: CCTH 2009/11/16 CHKD: CGTAN 2009/11/16 APPR: SILENI 2009/11/17 A7	QUALITY SYMBOLS $F_A=0$ $F_C=0$ $F_P=0$	GENERAL TOLERANCES (UNLESS SPECIFIED)		DIMENSION STYLE <b>MM ONLY</b>		SCALE NTS	DESIGN UNITS METRIC	THIRD ANGLE PROJECTION		
		4 PLACES	± ---	± ---	DRAWN BY JTAN	DATE 2004/05/26	TITLE DDR2 DIMM, 1.00MM PITCH 240 CKTS, 25 DEG. REVERSE ANGLE			
		3 PLACES	± ---	± ---	CHECKED BY MLONG	DATE 2004/06/11	MOLEX INCORPORATED			
		2 PLACES	± 0.25	± ---	APPROVED BY GGLEE	DATE 2004/06/11	MATERIAL NO. SEE TABLE	DOCUMENT NO. SD-87919-001	SHEET NO. 3 OF 6	
DRAFT WHERE APPLICABLE MUST REMAIN WITHIN DIMENSIONS		ANGULAR ± 5 °		SIZE A3		THIS DRAWING CONTAINS INFORMATION THAT IS PROPRIETARY TO MOLEX INCORPORATED AND SHOULD NOT BE USED WITHOUT WRITTEN PERMISSION				

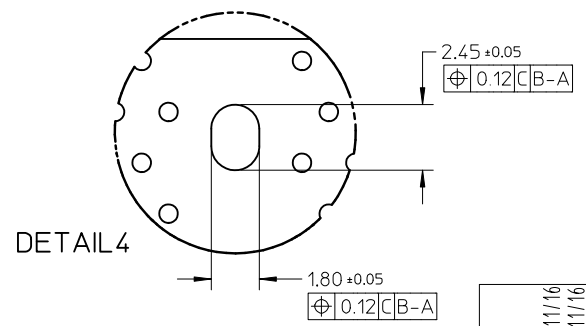
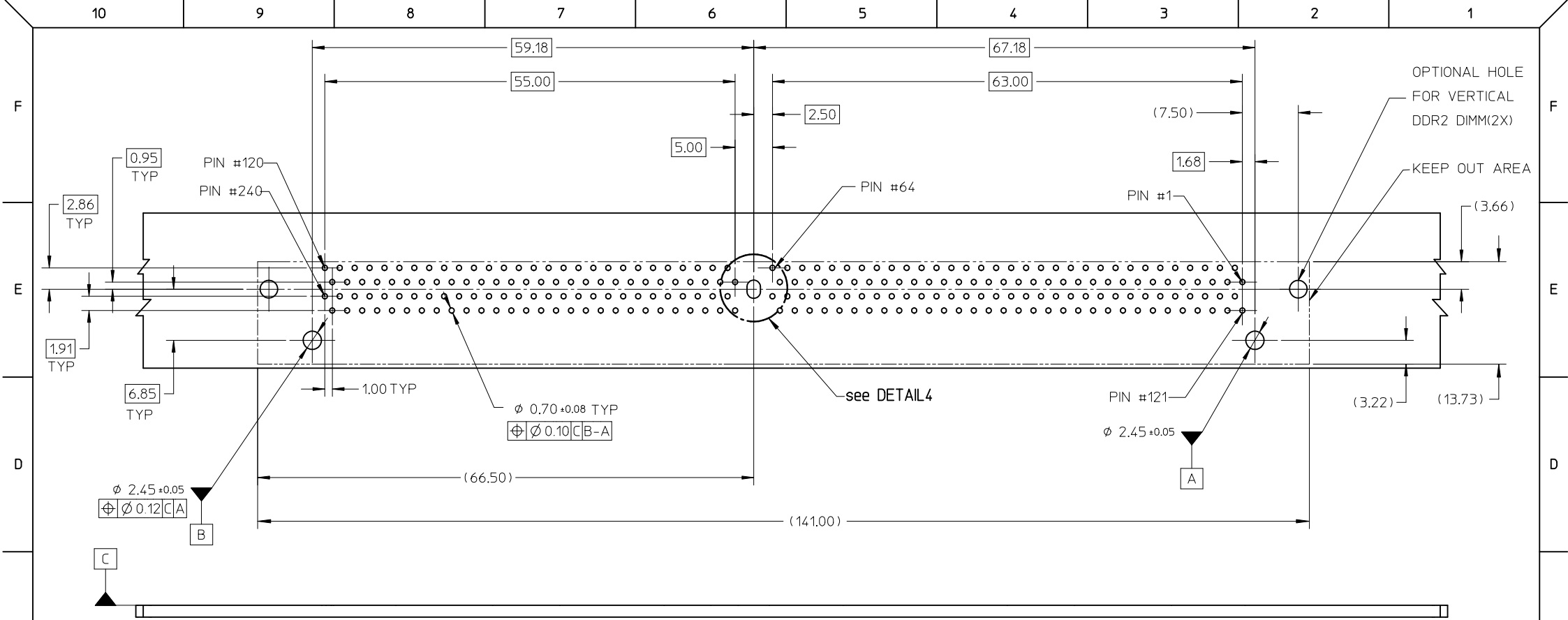

<b>ADDED OPTION</b> EC NO: S2010-0393 DRWN: CCTEH CH'KD: CGTAN APPR: SILENI	2009/11/16 2009/11/16 2009/11/17	DESCRIPTION REV	QUALITY SYMBOLS $F_A=0$ $F_C=0$ $F_B=0$	GENERAL TOLERANCES (UNLESS SPECIFIED) mm INCH 4 PLACES ± --- ± --- 3 PLACES ± --- ± --- 2 PLACES ± 0.25 ± --- 1 PLACE ± --- ± --- ANGULAR ± 5 °	DIMENSION STYLE <b>MM ONLY</b> DRAWN BY DATE JTAN 2004/05/26 CHECKED BY DATE MLONG 2004/06/11 APPROVED BY DATE GGLEE 2004/06/11	SCALE NTS DESIGN UNITS METRIC	TITLE DDR2 DIMM, 1.00MM PITCH 240 CKTS, 25 DEG. REVERSE ANGLE	THIRD ANGLE PROJECTION
	MATERIAL NO.		DRAFT WHERE APPLICABLE MUST REMAIN WITHIN DIMENSIONS		SEE TABLE		MOLEX INCORPORATED	SHEET NO. 4 OF 6
	DOCUMENT NO.		SD-87919-001		THIS DRAWING CONTAINS INFORMATION THAT IS PROPRIETARY TO MOLEX INCORPORATED AND SHOULD NOT BE USED WITHOUT WRITTEN PERMISSION			
	SIZE A3							

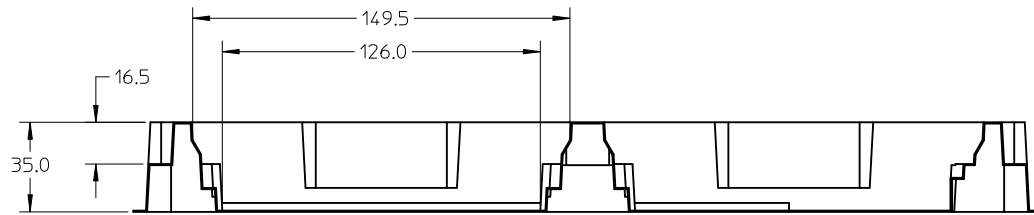
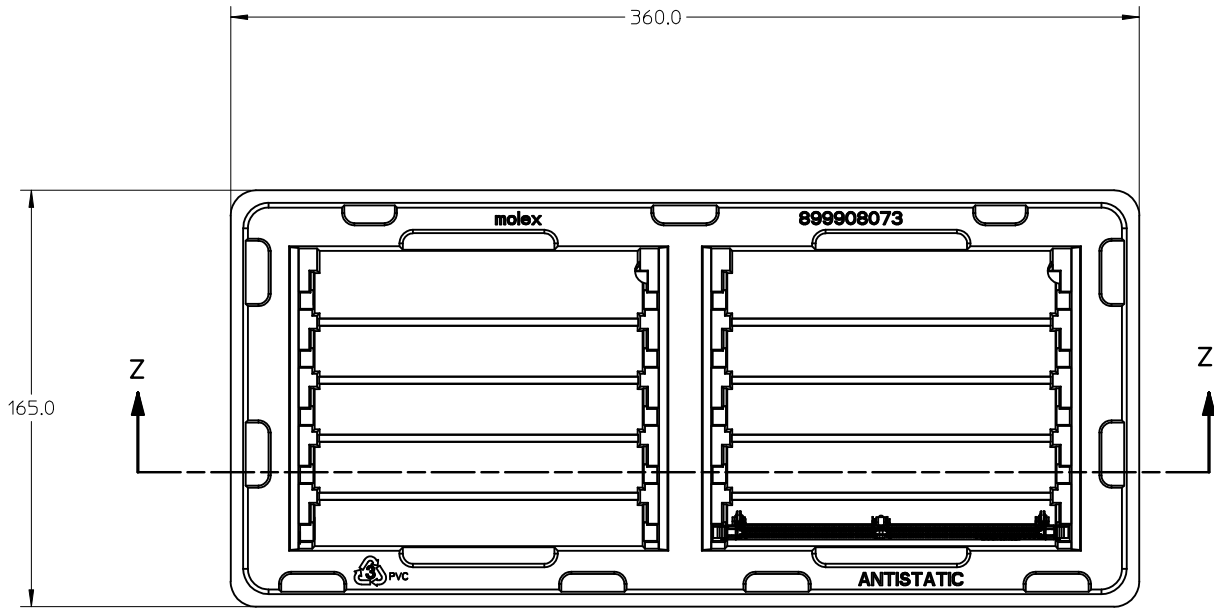

SECTION Z-Z

NOTE:  
1. CAVITY QTY : 2 X 5 = 10

ADDED OPTION EC NO: S2010-0393 DRWN:CCTEH 2009/11/16 CHKD:CGTAN 2009/11/16 APPR:SHLENI 2009/11/17	QUALITY SYMBOLS $F_A=0$ $F_C=0$ $F_P=0$	GENERAL TOLERANCES (UNLESS SPECIFIED)		DIMENSION STYLE MM ONLY		SCALE NTS	DESIGN UNITS METRIC	THIRD ANGLE PROJECTION		
			mm	INCH	DRAWN BY JTAN	DATE 2004/05/26	TITLE DDR2 DIMM, 1.00MM PITCH 240 CKTS, 25 DEG. REVERSE ANGLE			
		4 PLACES	±---	±---	CHECKED BY MLONG	DATE 2004/06/11	MOLEX INCORPORATED			
		3 PLACES	±---	±---	APPROVED BY GGLEE	DATE 2004/06/11	MATERIAL NO. SEE TABLE	DOCUMENT NO. SD-87919-001	SHEET NO. 5 OF 6	
			1 PLACE	±---	±---	THIS DRAWING CONTAINS INFORMATION THAT IS PROPRIETARY TO MOLEX INCORPORATED AND SHOULD NOT BE USED WITHOUT WRITTEN PERMISSION				
		ANGULAR ± 5 °		DRAFT WHERE APPLICABLE MUST REMAIN WITHIN DIMENSIONS						

10

9

8

7

6

5

4

3

2

1

PART NO.	VOLTAGE KEY	DIM 'P'	DIM 'Q'	RECOMMENDED PCB THICKNESS	CONTACT AREA PLATING	SOLDERTAIL PLATING	LATCH COLOR	
87919-0001	1.8V	2.79	3.18	1.57	0.76µM/ 30µ" GOLD OVER 1.27µM/ 50µ" MIN NICKEL	2.54µM/ 100µ" MIN. TIN OVER 1.27µM/ 50µ" MIN NICKEL	NATURAL	
87919-0011		3.18	4.83	2.36				
87919-1001		4.00		3.18				
87919-1002		4.60	3.50					
87919-0101		2.79	3.18	1.57	0.38µM/ 15µ" GOLD OVER 1.27µM/ 50µ" MIN NICKEL			BLACK
87919-0111		3.18	4.83	2.36				
87919-0333								

<b>ADDED OPTION</b> EC NO: S2010-0393 DRWN:CTEH 2009/11/16 CHKD:CGTAN 2009/11/16 APPR:SHLENI 2009/11/17	QUALITY SYMBOLS   	GENERAL TOLERANCES (UNLESS SPECIFIED)		DIMENSION STYLE <b>MM ONLY</b>		SCALE NTS	DESIGN UNITS METRIC	THIRD ANGLE PROJECTION
			mm	INCH	DRAWN BY	DATE	TITLE <b>DDR2 DIMM, 1.00MM PITCH          240 CKTS, 25 DEG.          REVERSE ANGLE</b>	
		4 PLACES	± ---	± ---	JTAN	2004/05/26		
		3 PLACES	± ---	± ---	CHECKED BY	DATE		
2 PLACES	± 0.25	± ---	MLONG	2004/06/11	APPROVED BY GGLEE	DATE 2004/06/11	<b>MOLEX INCORPORATED</b>	
1 PLACE	± ---	± ---	ANGULAR ± 5 °					
DRAFT WHERE APPLICABLE MUST REMAIN WITHIN DIMENSIONS				MATERIAL NO. <b>SEE TABLE</b>		DOCUMENT NO. <b>SD-87919-001</b>		SHEET NO. <b>6 OF 6</b>
THIS DRAWING CONTAINS INFORMATION THAT IS PROPRIETARY TO MOLEX INCORPORATED AND SHOULD NOT BE USED WITHOUT WRITTEN PERMISSION								

9

8

7

6

5

4

3

2

1