

## Precision CMOS Analog Switches

### DESCRIPTION

The DG417/418/419 monolithic CMOS analog switches were designed to provide high performance switching of analog signals. Combining low power, low leakages, high speed, low on-resistance and small physical size, the DG417 series is ideally suited for portable and battery powered industrial and military applications requiring high performance and efficient use of board space.

To achieve high-voltage ratings and superior switching performance, the DG417 series is built on Vishay Siliconix's high voltage silicon gate (HVSG) process. Break-before-make is guaranteed for the DG419, which is an SPDT configuration. An epitaxial layer prevents latchup.

Each switch conducts equally well in both directions when on, and blocks up to the power supply level when off.

The DG417 and DG418 respond to opposite control logic levels as shown in the Truth Table.

### FEATURES

- $\pm 15$  V Analog Signal Range
- On-Resistance -  $r_{DS(on)}$ : 20  $\Omega$
- Fast Switching Action -  $t_{ON}$ : 100 ns
- Ultra Low Power Requirements -  $P_D$ : 35 nW
- TTL and CMOS Compatible
- MiniDIP and SOIC Packaging
- 44 V Supply Max Rating

**RoHS\***  
COMPLIANT

### BENEFITS

- Wide Dynamic Range
- Low Signal Errors and Distortion
- Break-Before-Make Switching Action
- Simple Interfacing
- Reduced Board Space
- Improved Reliability

### APPLICATIONS

- Precision Test Equipment
- Precision Instrumentation
- Battery Powered Systems
- Sample-and-Hold Circuits
- Military Radios
- Guidance and Control Systems
- Hard Disk Drives

### FUNCTIONAL BLOCK DIAGRAM AND PIN CONFIGURATION

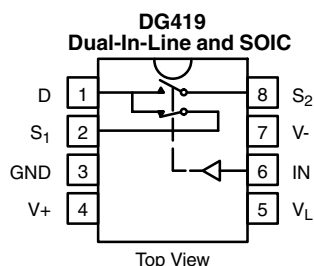
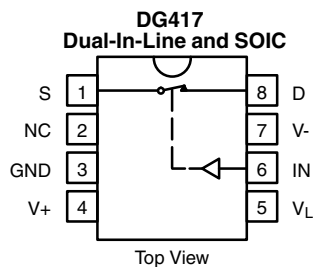

#### TRUTH TABLE

Logic	DG417	DG418
0	ON	OFF
1	OFF	ON

 Logic "0"  $\leq 0.8$  V

 Logic "1"  $\geq 2.4$  V

#### TRUTH TABLE - DG419

Logic	SW <sub>1</sub>	SW <sub>2</sub>
0	ON	OFF
1	OFF	ON

 Logic "0"  $\leq 0.8$  V

 Logic "1"  $\geq 2.4$  V

\* Pb containing terminations are not RoHS compliant, exemptions may apply



ORDERING INFORMATION		
Temp Range	Package	Part Number
<b>DG417/DG418</b>		
- 40 to 85 °C	8-Pin Plastic MiniDIP	DG417DJ DG417DJ-E3
		DG418DJ DG418DJ-E3
	8-Pin Narrow SOIC	DG417DY DG417DY-E3 DG417DY-T1 DG417DY-T1-E3
		DG418DY DG418DY-E3 DG418DY-T1 DG418DY-T1-E3
<b>DG419</b>		
- 40 to 85 °C	8-Pin Plastic MiniDIP	DG419DJ DG419DJ-E3
	8-Pin Narrow SOIC	DG419DY DG419DY-E3 DG419DY-T1 DG419DY-T1-E3

ABSOLUTE MAXIMUM RATINGS			
Parameter	Limit	Unit	
Voltages Referenced V+ to V-	44	V	
GND	25		
V <sub>L</sub>	(GND - 0.3) to (V+) + 0.3		
Digital Inputs <sup>a</sup> , V <sub>S</sub> , V <sub>D</sub>	(V-) - 2 to (V+) + 2 or 30 mA, whichever occurs first		
Current, (Any Terminal) Continuous	30	mA	
Current, S or D (Pulsed at 1 ms, 10 % duty cycle)	100		
Storage Temperature	(AK Suffix)	- 65 to 150	°C
	(DJ, DY Suffix)	- 65 to 125	
Power Dissipation (Package) <sup>b</sup>	8-Pin Plastic MiniDIP <sup>c</sup>	400	mW
	8-Pin Narrow SOIC <sup>d</sup>	400	
	8-Pin CerDIP <sup>e</sup>	600	

Notes:

- a. Signals on S<sub>X</sub>, D<sub>X</sub>, or IN<sub>X</sub> exceeding V+ or V- will be clamped by internal diodes. Limit forward diode current to maximum current ratings.
- b. All leads welded or soldered to PC Board.
- c. Derate 6 mW/°C above 75 °C.
- d. Derate 6.5 mW/°C above 75 °C.
- e. Derate 12 mW/°C above 75 °C.

**SCHEMATIC DIAGRAM (TYPICAL CHANNEL)**

Figure 1.

<b>SPECIFICATIONS<sup>a</sup></b>										
Parameter	Symbol	Test Conditions Unless Otherwise Specified $V_+ = 15\text{ V}$ , $V_- = -15\text{ V}$ $V_L = 5\text{ V}$ , $V_{IN} = 2.4\text{ V}$ , $0.8\text{ V}^f$	Temp <sup>b</sup>	Typ <sup>c</sup>	A Suffix - 55 to 125 °C		D Suffix - 40 to 85 °C		Unit	
					Min <sup>d</sup>	Max <sup>d</sup>	Min <sup>d</sup>	Max <sup>d</sup>		
<b>Analog Switch</b>										
Analog Signal Range <sup>e</sup>	$V_{ANALOG}$		Full		- 15	15	- 15	15	V	
Drain-Source On-Resistance	$r_{DS(on)}$	$I_S = -10\text{ mA}$ , $V_D = \pm 12.5\text{ V}$ $V_+ = 13.5\text{ V}$ , $V_- = -13.5\text{ V}$	Room Full	20		35	45	35	45	$\Omega$
Switch Off Leakage Current	$I_{S(off)}$	$V_+ = 16.5\text{ V}$ , $V_- = -16.5\text{ V}$ $V_D = \pm 15.5\text{ V}$ $V_S = \pm 15.5\text{ V}$	Room Full	- 0.1	- 0.25	0.25	- 0.25	0.25	nA	
	$I_{D(off)}$		DG417 DG418	Room Full	- 0.1	- 0.25	0.25	- 0.25		0.25
			DG419	Room Full	- 0.1	- 0.75	0.75	- 0.75		0.75
Channel Off Leakage Current	$I_{D(on)}$	$V_+ = 16.5\text{ V}$ , $V_- = -16.5\text{ V}$ $V_S = V_D = \pm 15.5\text{ V}$	DG417 DG418	Room Full	- 0.4	0.4	- 0.4	0.4	nA	
			DG419	Room Full	- 0.4	0.75	- 0.75	0.75		
<b>Digital Control</b>										
Input Current $V_{IN}$ Low	$I_{IL}$		Full	0.005	- 0.5	0.5	- 0.5	0.5	$\mu\text{A}$	
Input Current $V_{IN}$ High	$I_{IH}$		Full	0.005	- 0.5	0.5	- 0.5	0.5		
<b>Dynamic Characteristics</b>										
Turn-On Time	$t_{ON}$	$R_L = 300\ \Omega$ , $C_L = 35\text{ pF}$ $V_S = \pm 10\text{ V}$ See Switching Time Test Circuit	DG417 DG418	Room Full	100		175	250	175	ns
Turn-Off Time	$t_{OFF}$		DG417 DG418	Room Full	60		145	210	145	
Transition Time	$t_{TRANS}$	$R_L = 300\ \Omega$ , $C_L = 35\text{ pF}$ $V_{S1} = \pm 10\text{ V}$ , $V_{S2} = \pm 10\text{ V}$	DG419	Room Full			175	250	175	
Break-Before-Make Time Delay (DG403)	$t_D$	$R_L = 300\ \Omega$ , $C_L = 35\text{ pF}$ $V_{S1} = V_{S2} = \pm 10\text{ V}$	DG419	Room	13	5		5		
Charge Injection	Q	$C_L = 10\text{ nF}$ , $V_{gen} = 0\text{ V}$ , $R_{gen} = 0\ \Omega$		Room	60					pC
Source Off Capacitance	$C_{S(off)}$	$f = 1\text{ MHz}$ , $V_S = 0\text{ V}$		Room	8					pF
Drain Off Capacitance	$C_{D(off)}$		DG417 DG418	Room	8					
Channel On Capacitance	$C_{D(on)}$		DG417 DG418	Room	30					
			DG419	Room	35					

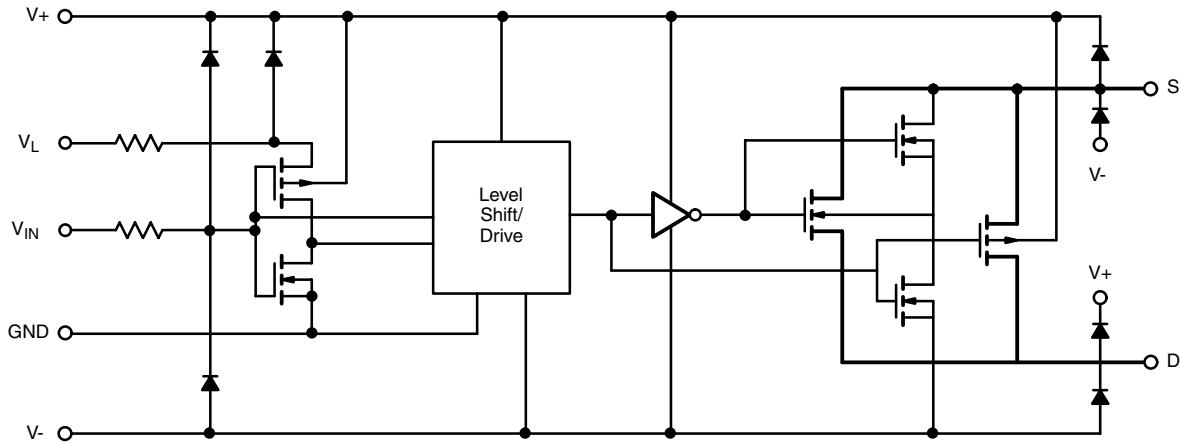

SPECIFICATIONS <sup>a</sup>									
Parameter	Symbol	Test Conditions Unless Otherwise Specified $V_+ = 15\text{ V}$ , $V_- = -15\text{ V}$ $V_L = 5\text{ V}$ , $V_{IN} = 2.4\text{ V}$ , $0.8\text{ V}^f$	Temp <sup>b</sup>	Typ <sup>c</sup>	A Suffix - 55 to 125 °C		D Suffix - 40 to 85 °C		Unit
					Min <sup>d</sup>	Max <sup>d</sup>	Min <sup>d</sup>	Max <sup>d</sup>	
<b>Power Supplies</b>									
Positive Supply Current	I <sub>+</sub>	$V_+ = 16.5\text{ V}$ , $V_- = -16.5\text{ V}$ $V_{IN} = 0\text{ or }5\text{ V}$	Room Full	0.001		1 5		1 5	μA
Negative Supply Current	I <sub>-</sub>		Room Full	-0.001	-1 -5		-1 -5		
Logic Supply Current	I <sub>L</sub>		Room Full	0.001		1 5		1 5	
Ground Current	I <sub>GND</sub>		Room Full	-0.0001	-1 -5		-1 -5		

SPECIFICATIONS FOR UNIPOLAR SUPPLIES <sup>a</sup>									
Parameter	Symbol	Test Conditions Unless Otherwise Specified $V_+ = 12\text{ V}$ , $V_- = 0\text{ V}$ $V_L = 5\text{ V}$ , $V_{IN} = 2.4\text{ V}$ , $0.8\text{ V}^f$	Temp <sup>b</sup>	Typ <sup>c</sup>	A Suffix - 55 to 125 °C		D Suffix - 40 to 85 °C		Unit
					Min <sup>d</sup>	Max <sup>d</sup>	Min <sup>d</sup>	Max <sup>d</sup>	
<b>Analog Switch</b>									
Analog Signal Range <sup>e</sup>	V <sub>ANALOG</sub>		Full		0	12	0	12	V
Drain-Source On-Resistance	r <sub>DS(on)</sub>	$I_S = -10\text{ mA}$ , $V_D = 3.8\text{ V}$ $V_+ = 10.8\text{ V}$	Room	40					Ω
<b>Dynamic Characteristics</b>									
Turn-On Time	t <sub>ON</sub>	$R_L = 300\text{ Ω}$ , $C_L = 35\text{ pF}$ , $V_S = 8\text{ V}$ See Switching Time Test Circuit	Room	110					ns
Turn-Off Time	t <sub>OFF</sub>		Room	40					
Break-Before-Make Time Delay	t <sub>D</sub>	DG419 Only $R_L = 300\text{ Ω}$ , $C_L = 35\text{ pF}$	Room	60					
Charge Injection	Q	$C_L = 10\text{ nF}$ , $V_{gen} = 0\text{ V}$ , $R_{gen} = 0\text{ Ω}$	Room	5					pC
<b>Power Supplies</b>									
Positive Supply Current	I <sub>+</sub>	$V_+ = 13.2\text{ V}$ , $V_L = 5.25\text{ V}$ $V_{IN} = 0\text{ or }5\text{ V}$	Room	0.001					μA
Negative Supply Current	I <sub>-</sub>		Room	-0.001					
Logic Supply Current	I <sub>L</sub>		Room	0.001					
Ground Current	I <sub>GND</sub>		Room	-0.001					

Notes:

- a. Refer to PROCESS OPTION FLOWCHART.
- b. Room = 25 °C, Full = as determined by the operating temperature suffix.
- c. Typical values are for DESIGN AID ONLY, not guaranteed nor subject to production testing.
- d. The algebraic convention whereby the most negative value is a minimum and the most positive a maximum, is used in this data sheet.
- e. Guaranteed by design, not subject to production test.
- f. V<sub>IN</sub> = input voltage to perform proper function.

Stresses beyond those listed under "Absolute Maximum Ratings" may cause permanent damage to the device. These are stress ratings only, and functional operation of the device at these or any other conditions beyond those indicated in the operational sections of the specifications is not implied. Exposure to absolute maximum rating conditions for extended periods may affect device reliability.

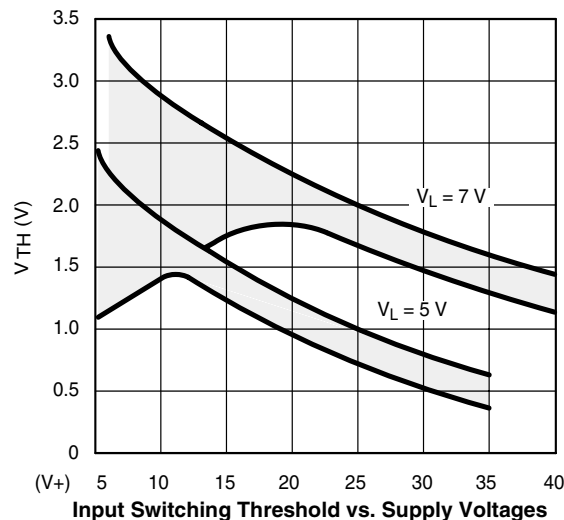
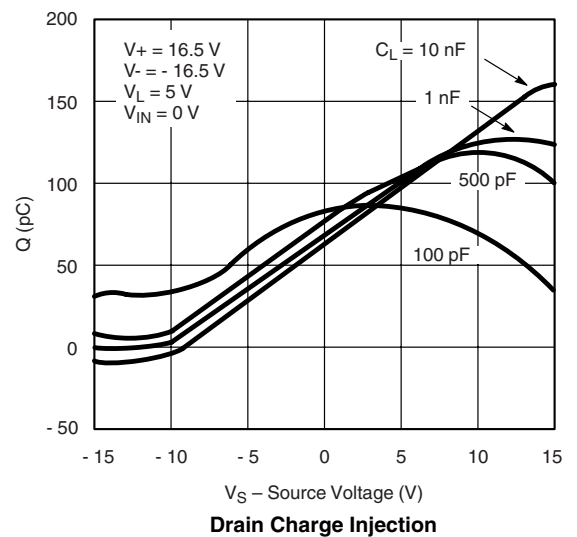
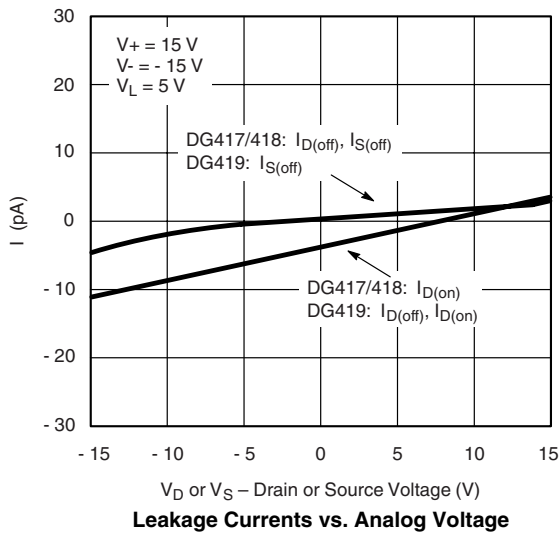
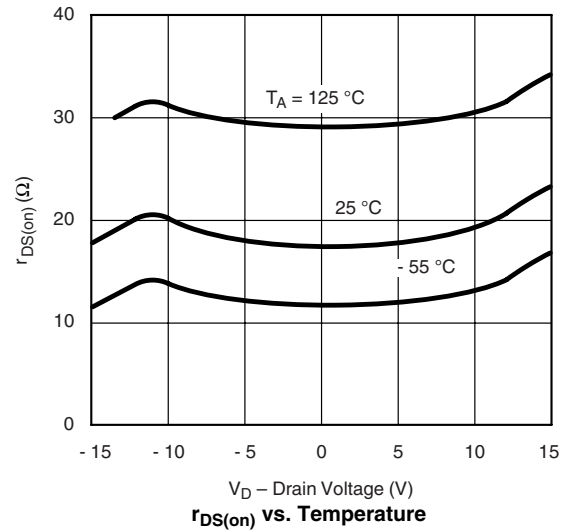
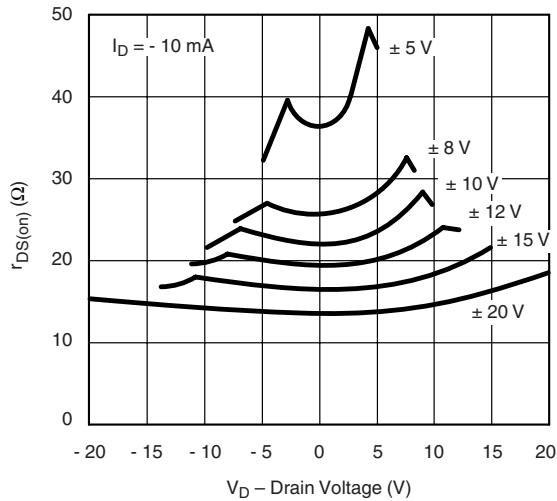
**TYPICAL CHARACTERISTICS** 25 °C, unless otherwise noted

### TYPICAL CHARACTERISTICS 25 °C, unless otherwise noted

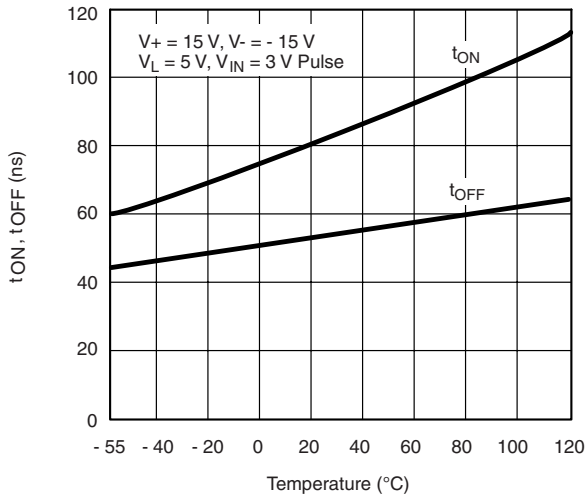

Switching Time vs. Temperature

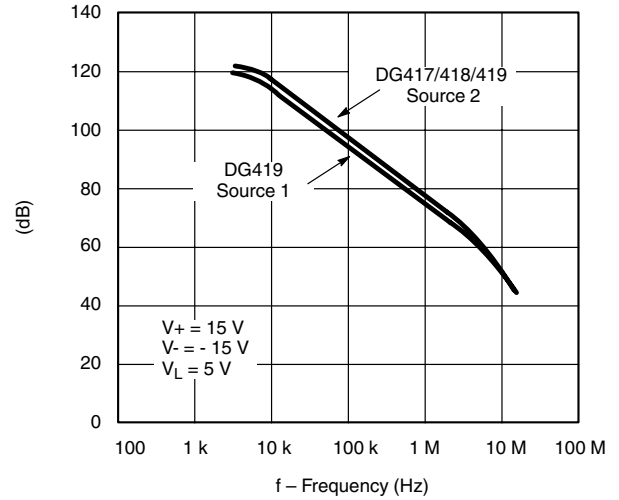

Crosstalk and Off Isolation vs. Frequency

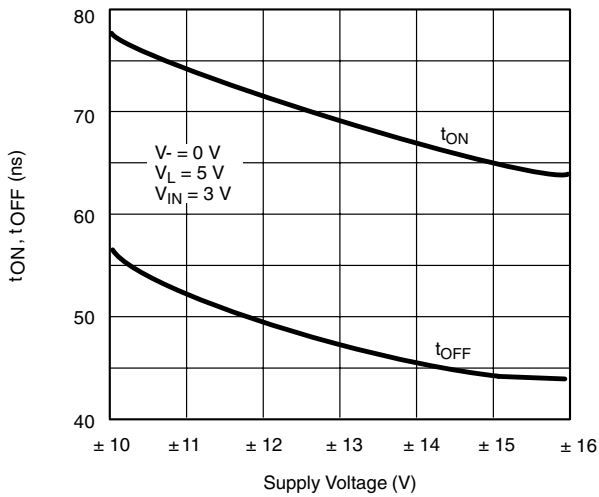

Switching Time vs. Supply Voltages

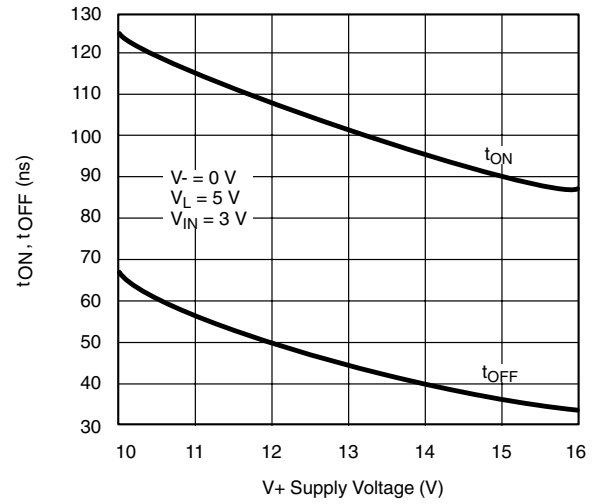

Switching Time vs.  $V_+$

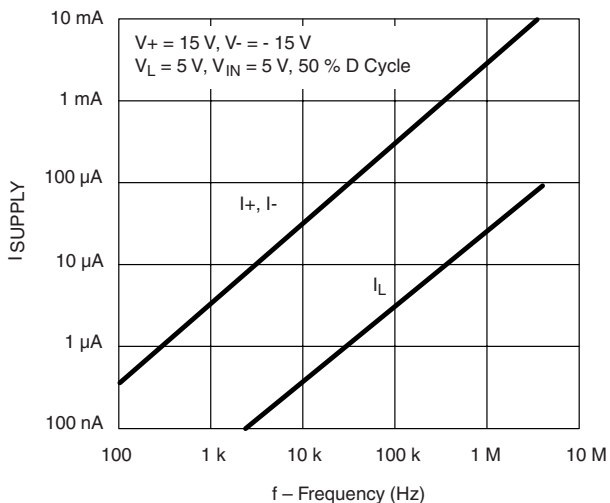

Power Supply Currents vs. Switching Frequency

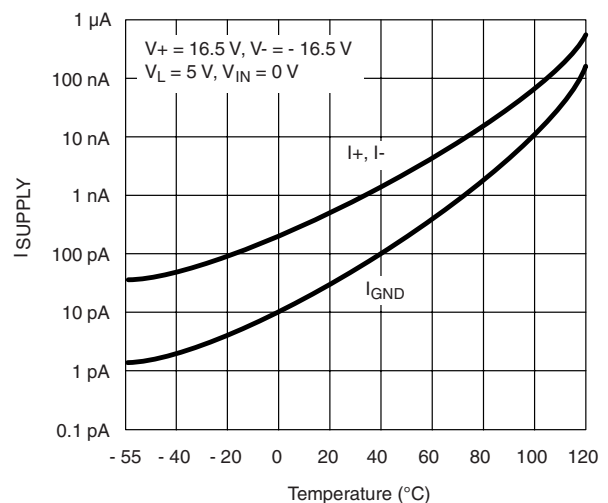

Supply Current vs. Temperature

**TEST CIRCUITS**

$V_O$  is the steady state output with the switch on.

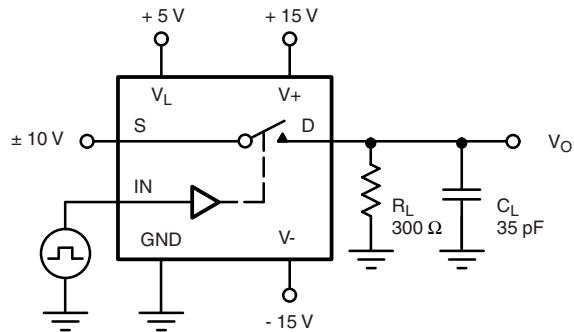

$C_L$  (includes fixture and stray capacitance)

$$V_O = V_S \frac{R_L}{R_L + r_{DS(on)}}$$

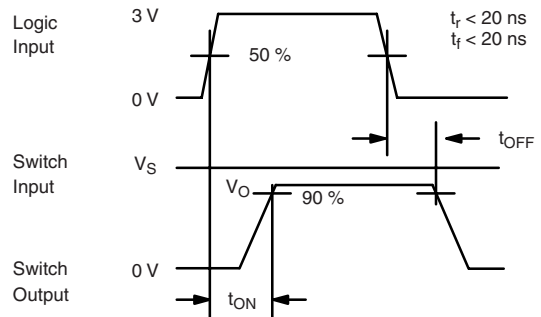

Note: Logic input waveform is inverted for switches that have the opposite logic sense.

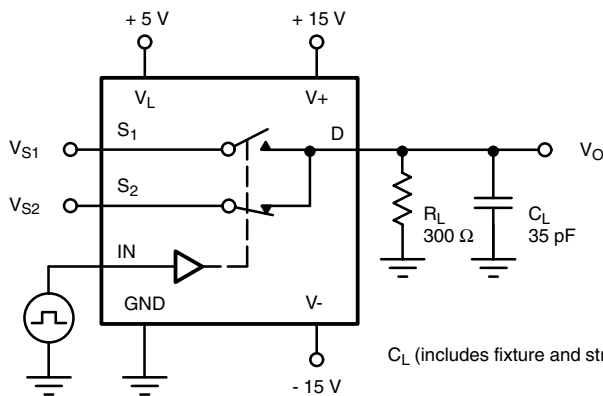
**Figure 2. Switching Time (DG417/418)**

$C_L$  (includes fixture and stray capacitance)

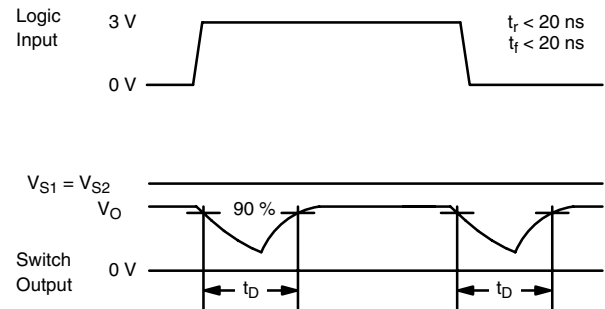
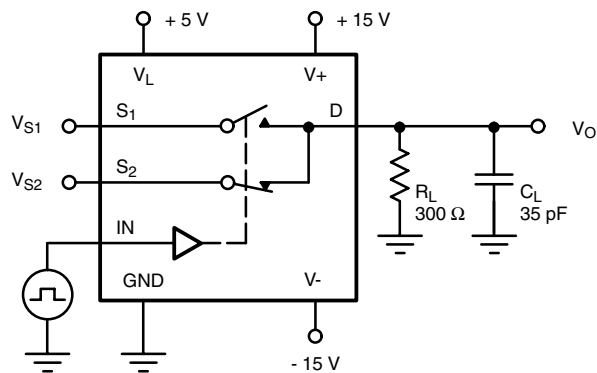
**Figure 3. Break-Before-Make (DG419)**

$C_L$  (includes fixture and stray capacitance)

$$V_O = V_S \frac{R_L}{R_L + r_{DS(on)}}$$

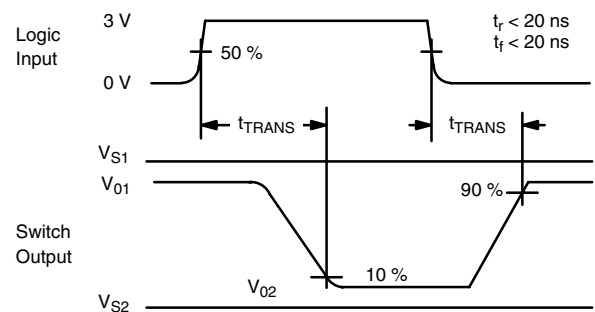
**Figure 4. Transition Time (DG419)**

TEST CIRCUITS

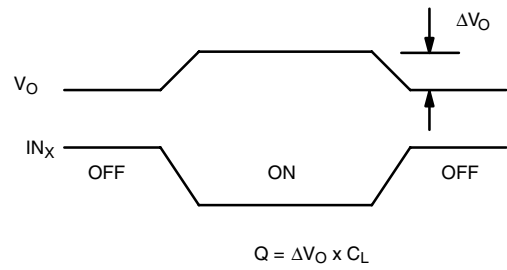
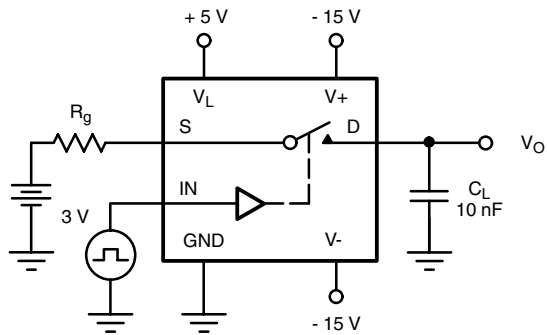

Figure 5. Charge Injection

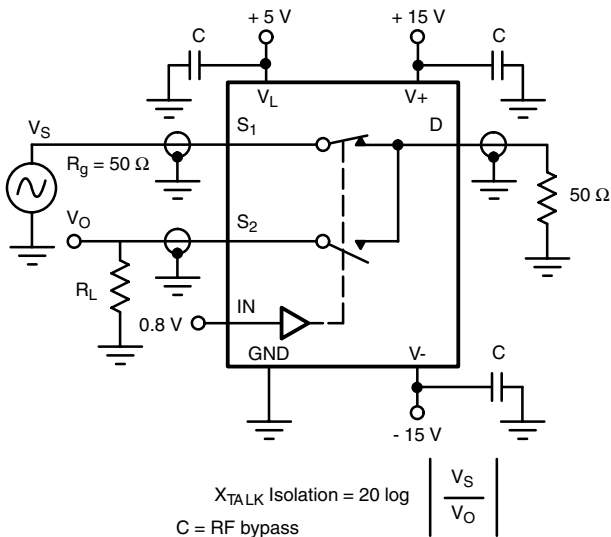

Figure 6. Crosstalk (DG419)

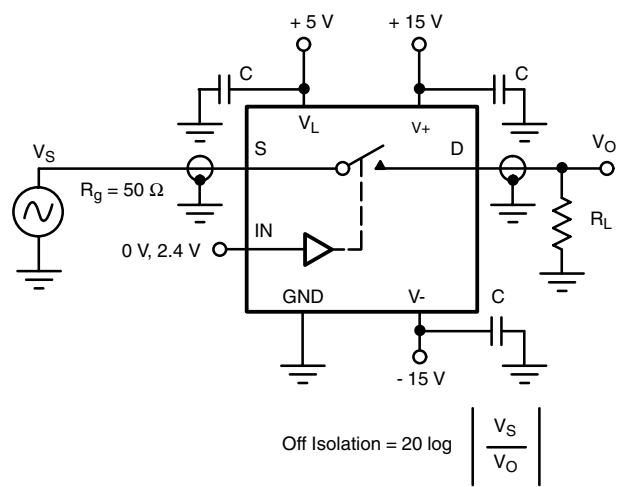

Figure 7. Off Isolation

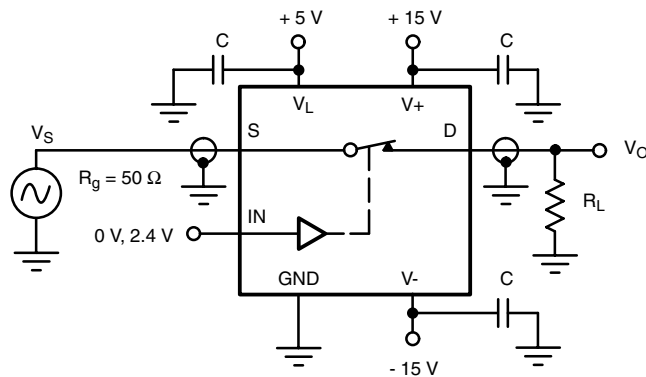
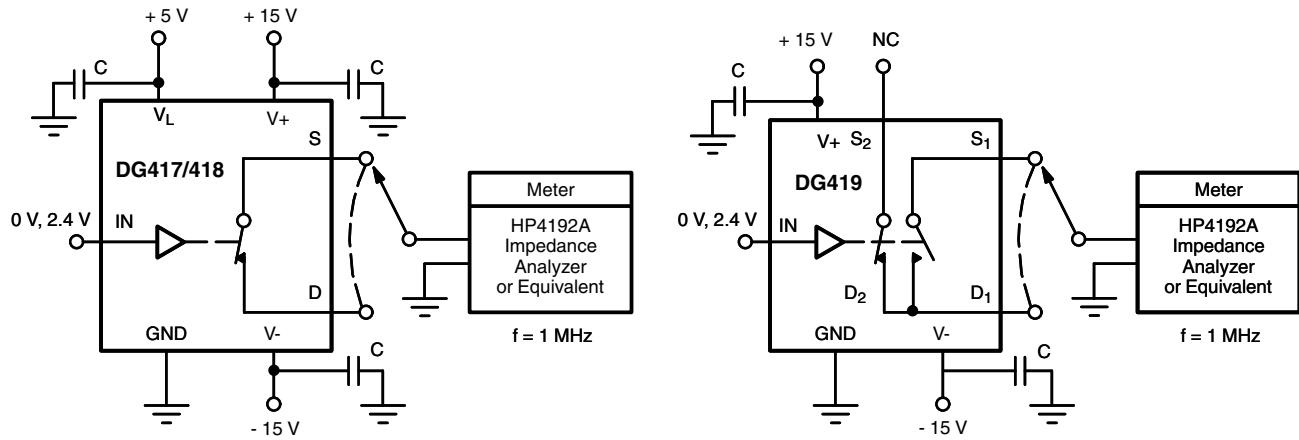

Figure 8. Insertion Loss



**TEST CIRCUITS**

**Figure 9. Source/Drain Capacitances**
**APPLICATIONS**
**Switched Signal Powers Analog Switch**

The analog switch in Figure 10 derives power from its input signal, provided the input signal amplitude exceeds 4 V and its frequency exceeds 1 kHz.

This circuit is useful when signals have to be routed to either of two remote loads. Only three conductors are required: one for the signal to be switched, one for the control signal and a common return.

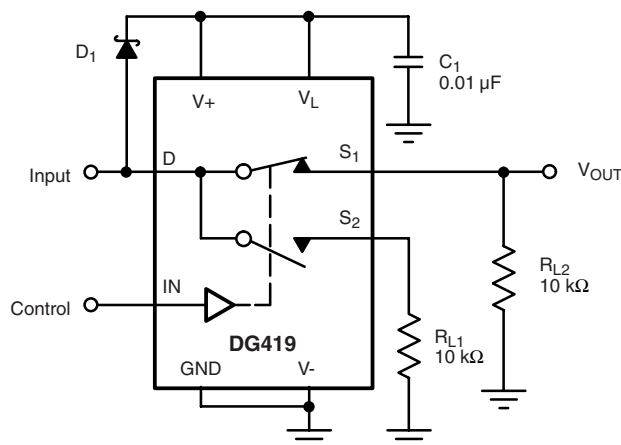
A positive input pulse turns on the clamping diode  $D_1$  and charges  $C_1$ . The charge stored on  $C_1$  is used to power the chip; operation is satisfactory because the switch requires less than 1  $\mu\text{A}$  of stand-by supply current. Loading of the signal source is imperceptible. The DG419's on-resistance is a low 100  $\Omega$  for a 5 V input signal.

**Figure 10. Switched Signal Powers Remote SPDT Analog Switch**

### APPLICATIONS

#### Micropower UPS Transfer Switch

When  $V_{CC}$  drops to 3.3 V, the DG417 changes states, closing  $SW_1$  and connecting the backup cell, as shown in Figure 10.  $D_1$  prevents current from leaking back towards the rest of the circuit. Current consumption by the CMOS analog switch is around 100 pA; this ensures that most of the power available is applied to the memory, where it is really needed. In the stand-by mode, hundreds of A are sufficient to retain memory data.

When the 5 V supply comes back up, the resistor divider senses the presence of at least 3.5 V, and causes a new change of state in the analog switch, restoring normal operation.

#### Programmable Gain Amplifier

The DG419, as shown in Figure 11, allows accurate gain selection in a small package. Switching into virtual ground reduces distortion caused by  $r_{DS(on)}$  variation as a function of analog signal amplitude.

#### GaAs FET Driver

The DG419, as shown in Figure 12 may be used as a GaAs FET driver. It translates a TTL control signal into - 8 V, 0 V level outputs to drive the gate.

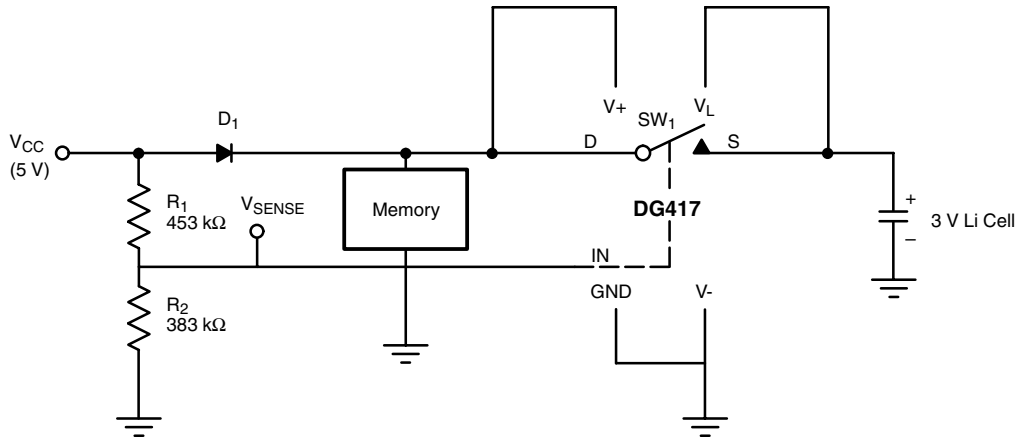

Figure 11. Micropower UPS Circuit

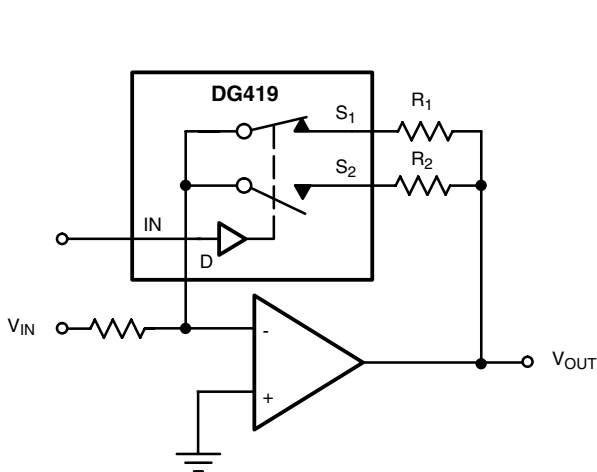

Figure 12. Programmable Gain Amplifier

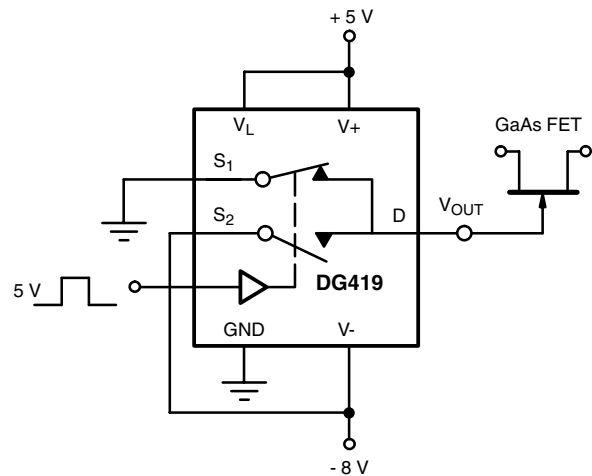

Figure 13. GaAs FET Driver

Vishay Siliconix maintains worldwide manufacturing capability. Products may be manufactured at one of several qualified locations. Reliability data for Silicon Technology and Package Reliability represent a composite of all qualified locations. For related documents such as package/tape drawings, part marking, and reliability data, see <http://www.vishay.com/ppg?70051>.



## Disclaimer

All product specifications and data are subject to change without notice.

Vishay Intertechnology, Inc., its affiliates, agents, and employees, and all persons acting on its or their behalf (collectively, "Vishay"), disclaim any and all liability for any errors, inaccuracies or incompleteness contained herein or in any other disclosure relating to any product.

Vishay disclaims any and all liability arising out of the use or application of any product described herein or of any information provided herein to the maximum extent permitted by law. The product specifications do not expand or otherwise modify Vishay's terms and conditions of purchase, including but not limited to the warranty expressed therein, which apply to these products.

No license, express or implied, by estoppel or otherwise, to any intellectual property rights is granted by this document or by any conduct of Vishay.

The products shown herein are not designed for use in medical, life-saving, or life-sustaining applications unless otherwise expressly indicated. Customers using or selling Vishay products not expressly indicated for use in such applications do so entirely at their own risk and agree to fully indemnify Vishay for any damages arising or resulting from such use or sale. Please contact authorized Vishay personnel to obtain written terms and conditions regarding products designed for such applications.

Product names and markings noted herein may be trademarks of their respective owners.