

SPECIFICATIONS

PARAMETERS	VALUES	UNITS
RATED VOLTAGE	1.5	Vpk
OPERATING VOLTAGE RANGE	1 ~ 4	Vpk
RATED CURRENT (MAX)	10	mA
COIL RESISTANCE	45 ± 7.5	OHM
MINIMUM SPL @ 10 CM	78	dBA
RESONANT FREQUENCY	2,048 ± 500	Hz
OPERATING TEMPERATURE	-20 ~ +60	°C
STORAGE TEMPERATURE	-30 ~ +70	°C
HOUSING MATERIAL	PPO	-
TERMINAL MATERIAL	Sn PLATED BRASS	-
WEIGHT	2	grams

THIS DOCUMENT CONTAINS DATA PROPRIETARY TO PROJECTS UNLIMITED, INC. ANY USE OR REPRODUCTION, IN ANY FORM, WITHOUT PRIOR WRITTEN PERMISSION OF PROJECTS UNLIMITED, INC. IS PROHIBITED.
©2003, Projects Unlimited Inc.

REVISION HISTORY

LTR	DESCRIPTION	DATE	APPROVED
-	RELEASED FROM ENGINEERING	7/23/2014	
A	REVISED COIL RESISTANCE	9/27/2018	M.L.

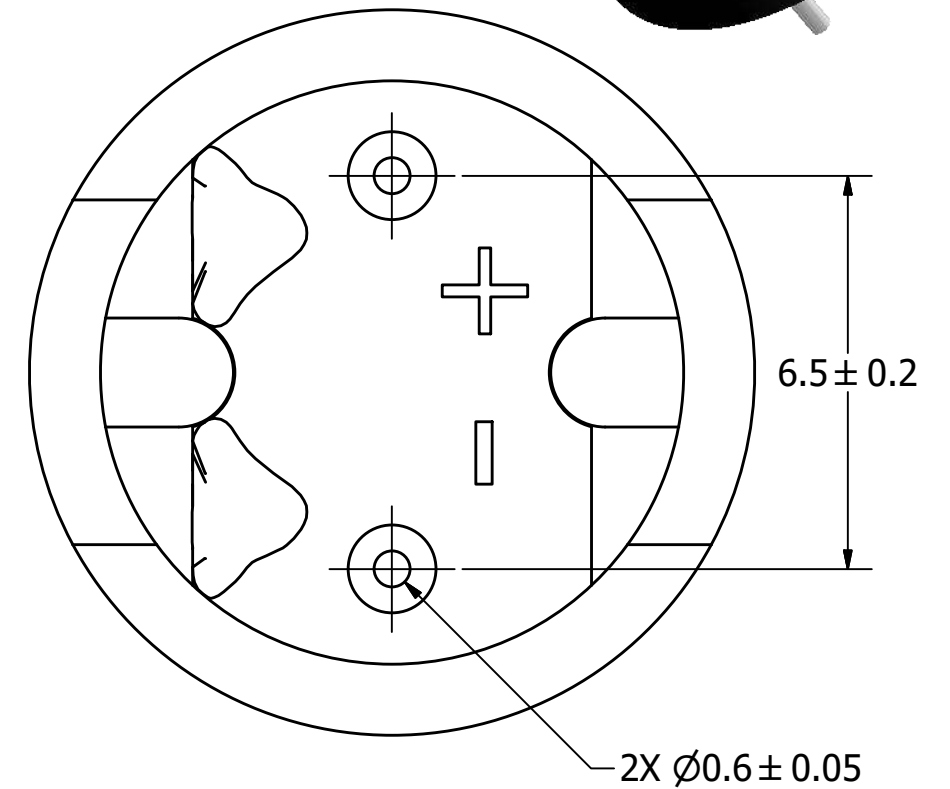
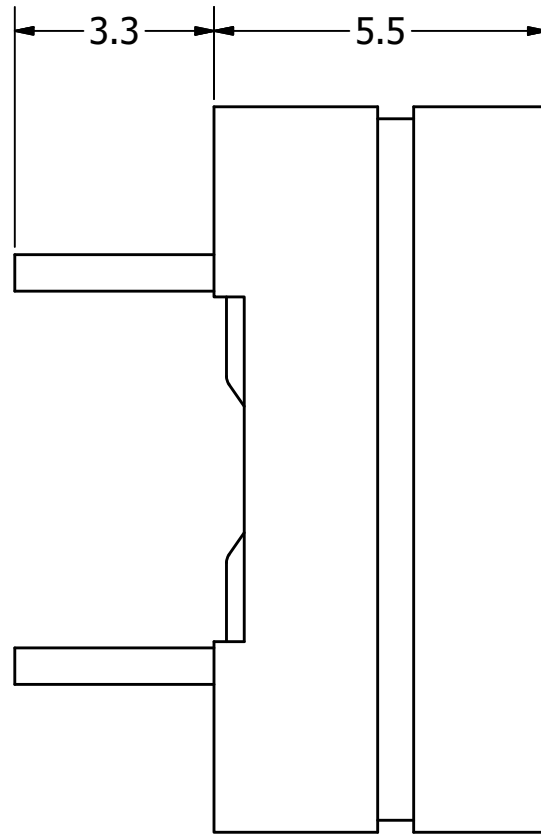
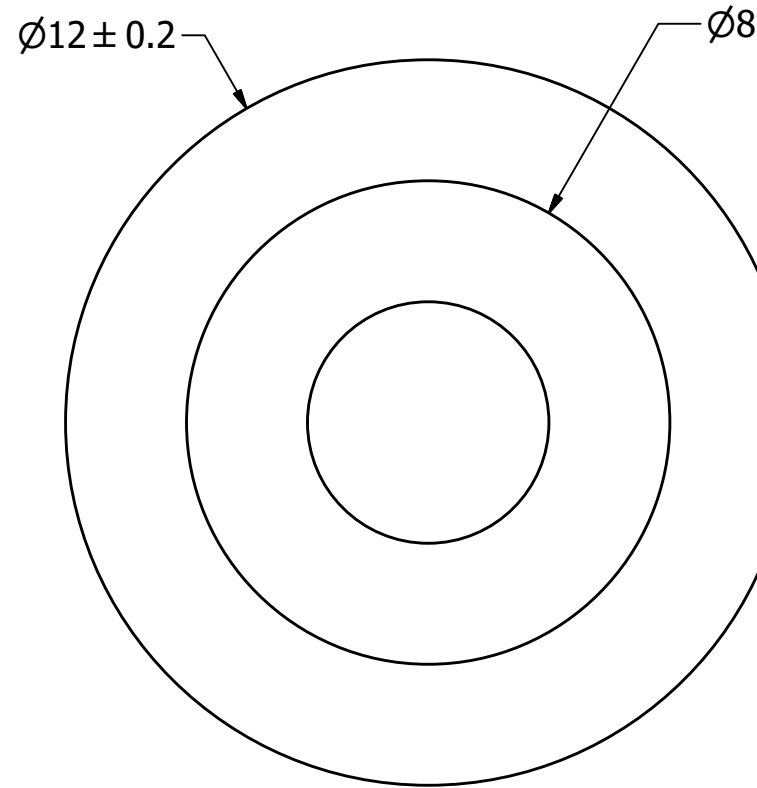

NOTES:

1. ALL DIMENSIONS ARE IN MILLIMETERS.
2. SPECIFICATIONS SUBJECT TO CHANGE OR WITHDRAWL WITHOUT NOTICE.
3. THIS PART IS RoHS 2011/65/EU COMPLIANT.

UNLESS OTHERWISE SPECIFIED:
ALL PURCHASES ARE SUBJECT TO AND INCORPORATE THE PUI AUDIO TERMS AND CONDITIONS SALE FOUND AT http://www.puiaudio.com/pdf/terms_conditions.pdf (paper copy available upon request). DIMENSIONS ARE IN MILLIMETERS, TOLERANCES ARE ±0.5 AND ANGLES ARE ±3°.

SIZE
A3

Designed by	Date	Checked by	Date	Approved by	Date	Drawn Date
J.D.	7/23/2014	C.W.	7/23/2014	B.R.	7/23/2014	7/23/2014



AT-1220-TT-11-R

Transducer (Electro-Mech)	Edition	Sheet
	-	1 / 1

AT-1220-TT-11-R.idw