

LOC
A1

DIST
-

REVISIONS

P	LTR	DESCRIPTION	DATE	DWN	APVD
D3		ECR-11-009482	09MAY2011	VG	BR
D4		ECR-15-014241	27OCT2015	RK	JB
D5		REV. PER ECR-16-000458	12JAN2016	ER	DO
D6		ITEM 4 EXCHANGED PER PCN E-16-007296	20MAY2016	ER	DO

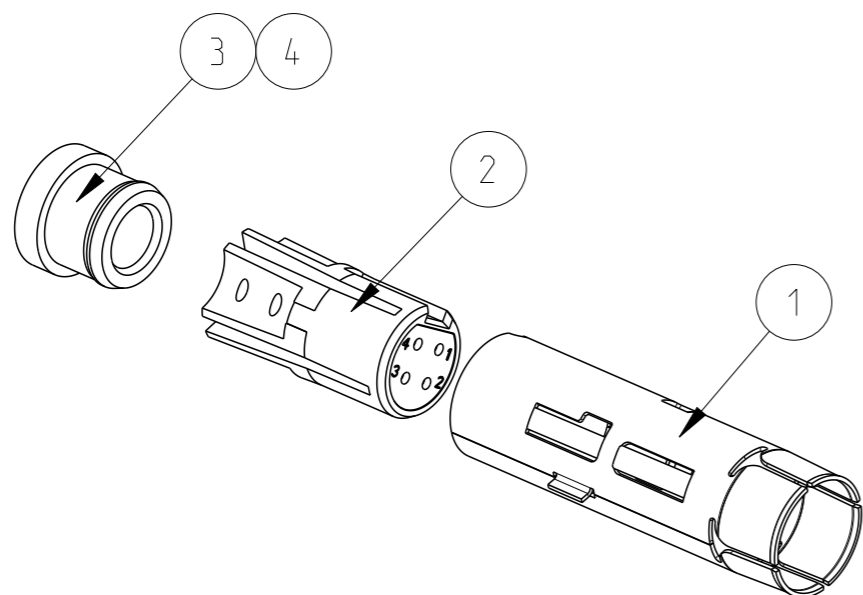
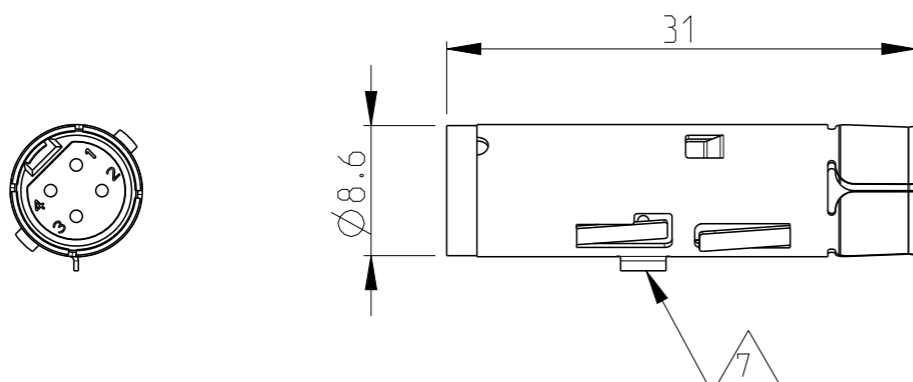

Notes

- 1 SUITABLE POWER INSERT: SERIES HC26
CUSTOMER DRAWING: 1103428
- 2 SUITABLE CAT5e CABLE:
CUSTOMER DRAWING: 1103536
- 3 SUITABLE CRIMP CONTACTS:
CUSTOMER DRAWING: 1658670
- 4 SUITABLE INSERTION TOOL:
CUSTOMER DRAWING: 91285
- 5 SUITABLE EXTRACTION TOOL:
CUSTOMER DRAWING: 91285
- 6 STANDARDS:
DIN EN 61984, DIN EN 60664-1
- 7 POLARIZATION RIP
- 8 PACKAGING:
40 SETS IN A CARTON, UNMOUNTED

PN 0--1 AND 0--2 AS SHOWN

QTY	0--1	0--2	DESCRIPTION	MATERIAL	SURFACE/COLOR	NOTE	ITEM
-	1	-	FERRULE	BRASS	SILVER PLATED	SERIES HC26, MALE SHELL	4
-	-	1	FERRULE	BRASS	SILVER PLATED	SERIES HC26, MALE SHELL	3
-	1	1	MALE INSERT ASS'Y			SERIES HC26, 4-POS. 22DF	2
-	1	1	MALE SHELL	COPPER ALLOY	SILVER PLATED	SERIES HC26, 4-POS. 22DF	1

QTY REQD PER ASSY		PARTS LIST						
THIS DRAWING IS A CONTROLLED DOCUMENT.		DWN H.BRAUN 27OCT2008	 TE Connectivity MALE INSERT ASS'Y SERIES HC26, 4-POS. 22DF CIRCULAR HYBRID CONNECTOR					
DIMENSIONS: mm		CHK T.VETTER 27OCT2008						
		APVD T.SCHNURPFEL 27OCT2008						
TOLERANCES UNLESS OTHERWISE SPECIFIED:		PRODUCT SPEC 108-94485						
MATERIAL -		FINISH -	APPLICATION SPEC 114-94369	WEIGHT -	SIZE A3	CAGE CODE 00779	DRAWING NO C=1103426	RESTRICTED TO -
Customer Drawing			SCALE 2:1	SHEET 1	OF 1	REV D6		