

OV480 companion processor product brief



Powerful Electronic Distortion Correction for Automotive Vision Systems



available in
a lead-free
package

OmniVision's OV480 is a low-cost companion processor designed to enhance camera performance in wide field-of-view (FOV) automotive vision systems. The OV480 works with OmniVision's high-performance AutoVision image sensors up to megapixel resolution to deliver best-in-class electronic distortion correction and enhanced low-light performance. Due to the processor's ability to correct lens distortion up to 195-degrees, the OV480 allows a single camera to be used across multiple vehicle platforms.

The OV480's low-light performance enhancement and temporal noise filter significantly enhances nighttime

user experience. The highly compact ASIC processor also provides top down and perspective views, which offers clear imaging for specific rear-view driving functions such as trailer ball hitching. Additionally, the OV480 has a cross traffic view feature, allowing drivers to see around side obstacles.

The compact yet powerful OV480 companion processor also supports user-defined hot pixel correction, rotation correction, and up to 4x zoom with smooth transition options.

Find out more at www.ovt.com.

Applications

- Smart Camera
- Rear View Camera for Ultra Wide Field of View
- Rear View Camera with Trailer Ball Zoom
- Surround View
- Cross Traffic Camera

Product Features

- interface up to megapixel OmniVision CMOS digital sensor (e.g., OV7955/OV7692, OV10635)
- image distortion correction
- image perspective correction
- image rotation correction
- multi-view output
- up to 4x zoom with smooth transition
- crop and resize for NTSC display
- fade to black transition and morphing
- supports down to 15 fps sensor frame-rate to enable better sensitivity in low-light scenarios
- supports video de-noise filtering
- supports 1x1 pixel OSD, up to 4 layers, 4 transparency levels, 8 colors per pixel, 2¹⁶ bit image index
- brown-out detection circuit and output flag
- on-chip MCU with 7 dedicated GPIO (interrupts)
- user-defined hot-pixel location correction
- digital input (sensor) interface support 8-bit CCIR601 YUV 4:2:2 format
- digital output interface support 8-bit CCIR656/601 YUV 4:2:2 format
- SCCB master interface for automatic sensor configuration at power-on
- on chip DAC for CVBS output
- supports NTSC-D1 (27 MHz) analog video specifications
- SCCB slave interface for OV480 configuration by host
- supports serial interface and two-wire serial interface to retrieve stored configuration and OSD bitmap images from external memory devices such as EEPROM
- on chip voltage regulator 3.3V to 1.2V
- on chip PLL to generate stable internal clock frequency
- supports OSD position calibration (auto-overlay alignment)

OV480



Ordering Information

- OV00480-B81G-Z (lead-free, 81-pin BGA)

Product Specifications

- **power supply:**
 - core: 1.2V ±10%
 - I/O: 3.3V ±10%
- **ambient operating temperature range:**
 - 40°C to +105°C (not to exceed 125°C junction temperature)
- **power requirements:**
 - 250 mA maximum at room temperature
- **package dimensions:**
 - 6.5 mm x 6.5 mm

System Block Diagram

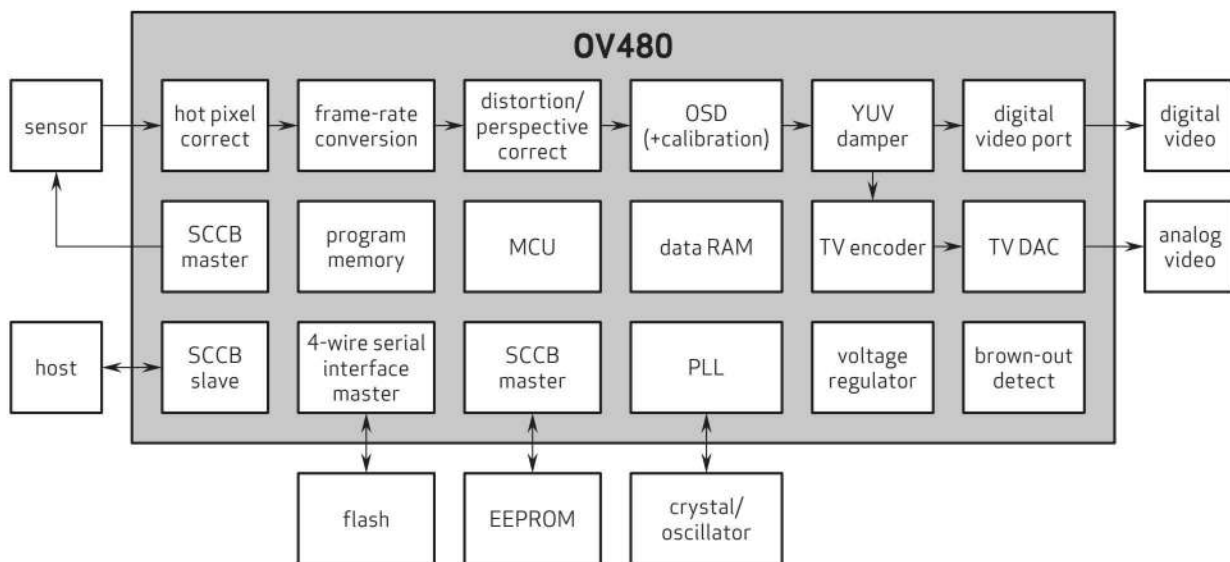

4275 Burton Drive
Santa Clara, CA 95054
USA

Tel: +1 408 567 3000
Fax: +1 408 567 3001
www.ovt.com

OmniVision reserves the right to make changes to their products or to discontinue any product or service without further notice. OmniVision, the OmniVision logo and OmniPixel are registered trademarks of OmniVision Technologies, Inc. OmniBSI is a trademark of OmniVision Technologies, Inc. All other trademarks are the property of their respective owners.