

SIGN	DATE	DESCRIPTION	APPROVER
△	02/03'05	Part No. changed.	Marvin
△	06/26'06	Solid/Stranded wire(AWG) is changed from 12-22 to 12-24	Marvin
△	8/10'06	Added VDE and TUV standard	梁仁松
△	12/17'08	Add the tolerance table	Jacke
△	12/17'08	The temperature changed from -30°C,+105°C to -40°C,+115°C	Jacke
△	03/08'10	Add the 2P mark	Jacke
△	04/03'14	Update the drawing	Chen Bo

THIS IS CAD DRAWING, DO NOT REVISE MANUALLY!!!

TJ xx 71x 0 xxxx G

No. OF POLES
 02 2 CONTACTS
 03 3 CONTACTS

 24 24 CONTACTS

COLOR
 0 Black (RAL9005)
 2 Red (RAL3001/D)
 3 Orange(RAL2011/P)
 4 Yellow(RAL1018/A)
 5 Green(RAL6018/T)
 6 Blue (RAL5015/A)
 8 Grey(RAL7035/D)
 9 White(RAL1102)
 C Green(RAL6018/U)

G RoHS compliant (lead<4%)
 In copper Alloy
 00Y0: "@" Logo (Standard)
 00YA: "ANYTEK" Mark
 Any special item by customer request.
 please contact sales department.

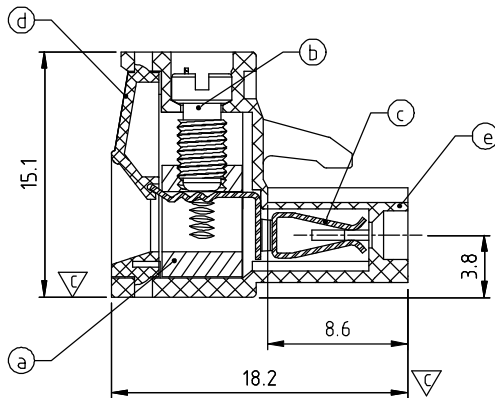
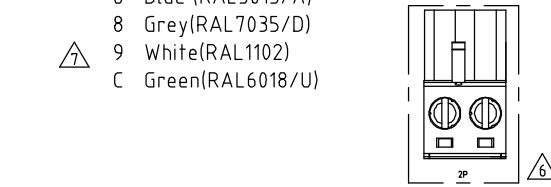
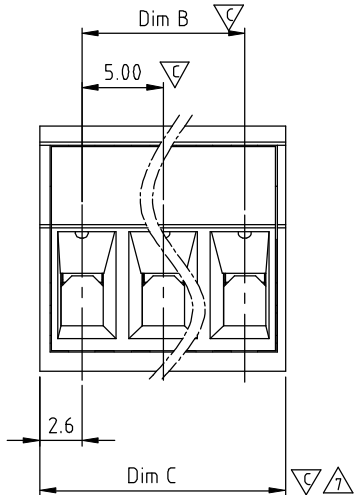
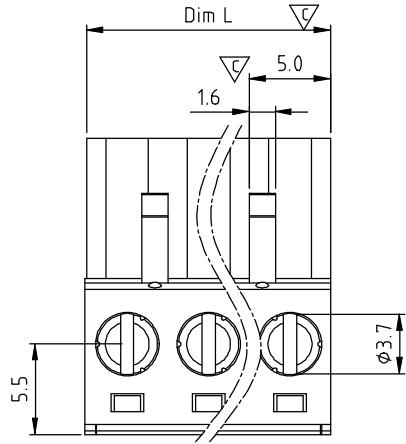

Material

- Item (a) Clamp: Brass(CuZn) Ni plated
- Item (b) Terminal screw: Steel Zinc plating "-" slot type
- Item (c) Female contact: PhBz ,Tin plated
- Item (d) Terminal Cover: Thermoplastic (UL94V-0)
- Item (e) Terminal housing: Thermoplastic (UL94V-0)

Electrical cULus/VDE/TUV

- Voltage rating: 300VAC/300VAC/300VAC
- Current rating: 20A/20A/20A
- Wire range: 2.5mm²/0.34-2.5mm²
- Solid wire(AWG): 12-24/14-22
- Stranded wire(AWG): 12-24/14-22
- Torque: 5Lb-In/0.5Nm/0.56Nm
- Screw: M3
- Wire strip length: 7-8mm
- Withstanding Voltage: 1.6KV/2.5KV/2.5KV
- Operating temperature: -40°C to +115°C
- Safety Approval: cULus VDE TUV
- Critical dimension: △

△ △ N= Number of poles

Dimension	Poles	Tolerance
Dim L N×5.0	2P-7P	±0.15
Dim B (N-1)×5.0	8P-12P	±0.25
Dim C N×5.0+0.10	13P-18P	±0.30
	19P-24P	±0.40

ANYTEK				CUSTOMER COPY			
ALL RIGHTS RESERVED. REPRODUCTION OR ISSUE TO THIRD PARTIES IN ANY FORM WHATSOEVER IS NOT PERMITTED WITHOUT WRITTEN AUTHORITY FROM THE PROPRIETOR. PROPERTY OF ANYTEK TECHNOLOGY CO., LTD							
TITLE		TJ-5.00mm Series					
PART NO.		TJxx71x0xxxxG			DWG NO.		8TJ0301
APPROVED		CHECKED		DESIGNED		DRAWN	
		Chen Bo 04/03'14		Chen Bo 04/03'14		CUST NO.	
						Tolerance	
						X. ±0.50	
						X.X ±0.30	
						X.XX ±0.10	
						X° ±1°	
						UNIT: mm	
						SCALE: NONE	
						REV.: H	
				SHEET: 01/01			