

THESE DRAWINGS ARE THE PROPERTY OF QUALTEK ELECTRONICS AND NOT TO BE REPRODUCED FOR OR COMMUNICATED TO A THIRD PARTY WITHOUT THE EXPRESS WRITTEN PERMISSION OF AN OFFICER OF QUALTEK ELECTRONICS.

REVISION			
REV.	DESCRIPTION	DATE	APPROVED
B	Updated Specifications	02-09-12	LY

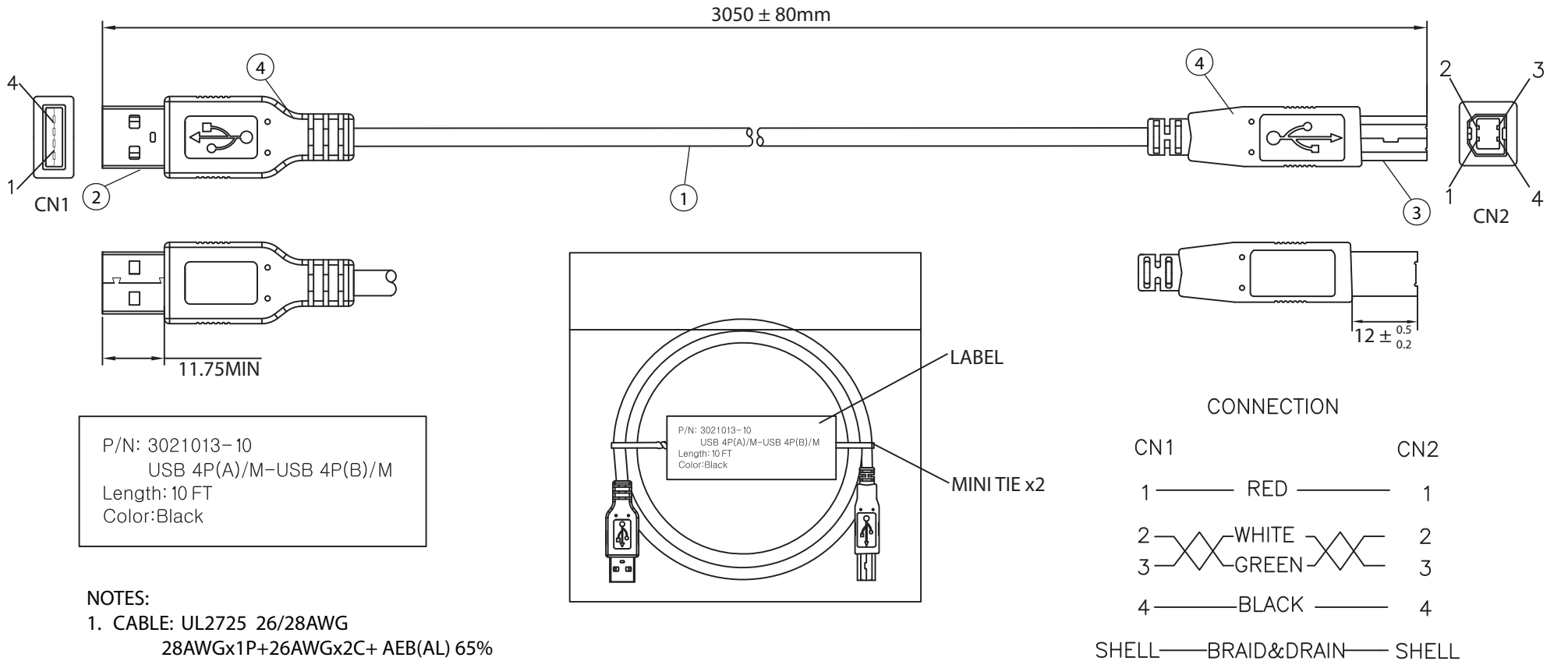

P/N: 3021013-10
 USB 4P(A)/M-USB 4P(B)/M
 Length: 10 FT
 Color: Black

NOTES:

- CABLE:** UL2725 26/28AWG
 28AWGx1P+26AWGx2C+ AEB(AL) 65%
 OUTER JACKET: BLACK, OD: 4.2 ± 0.2mm
- CONNECTOR:** USB A TYPE MALE
 INSULATOR: WHITE PBT
 PIN G/F
 NICKEL PLATED SHELL
- CONNECTOR:** USB B TYPE MALE
 INSULATOR: WHITE PBT
 PIN G/F
 NICKEL PLATED SHELL
- PVC MOLDED:** COLOR V398 45P BLACK
- ELECTRICAL TEST:**
 <1>.100% OPEN SHORT & MISS WIRE TEST
 <2>.INSULATION RESISTANCE: DC400V 10M ohm MIN.
 <3>.CONDUCTOR RESISTANCE: 3 ohm MAX.
- PACKING:** 1PC/POLYBAG W/ LABEL

CONNECTION

CN1		CN2
1	— RED —	1
2	— WHITE —	2
3	— GREEN —	3
4	— BLACK —	4
SHELL — BRAID&DRAIN —		SHELL

CONTROLLED

Dim range (mm)	Tolerance +/- (mm)	Qualtek Electronics Corp.		
		WCI DIVISION		
0-1	0.15	Part Number: 3021013-10		
1-6	0.20	RoHS Compliant		
6-18	0.30	Description: USB 4P(A)/M - USB 4P(B)/M		
18-50	0.50		UNIT: mm	REV. B
50-120	0.70	Drawn / Date	Checked / Date	Approved / Date
120-250	0.90	B. Grubb 01-26-07	01-26-07	JJH / 01-26-07
250-500	1.20			